



MIPI CSI-2 CAMERAS

Alvium CSI-2 Cameras User Guide

This user guide applies to Alvium 1500 C and 1800 C cameras, and it is the basic reference for Alvium FP3/GM2 cameras. For individual information on Alvium FP3/GM2 cameras, especially interface descriptions and instructions, please see the **Alvium FP3/GM2 User Guide** at www.alliedvision.com/en/support/technical-documentation/alvium-csi-2-documentation.

Note: Lenses are not part of this product.

V3.5.1

FW 00.13.00.e83c9689

**Quick links**

- [Alvium CSI-2 cameras at a glance](#) on page 15
- [Contact us](#) on page 22
- [Contents](#) on page 23

Read before use

EN - English

Safety

Before using the camera, read these safety instructions. Observe the warnings at all times. Use the camera only as stated in the [Intended use](#) on page 50.

**CAUTION****Risk of burns**

A camera in operation can reach temperature levels which could cause burns.

**CAUTION****Injury by falling cameras or lenses**

A falling camera or lens can cause injury.

**CAUTION****Risk of cuts by sharp edges**

The product can have sharp edges.

Intended use

Intended use of Allied Vision product is the integration into vision systems by professionals. All Allied Vision product is sold in a B2B setting.

Cameras without closed housings

Cameras without housing or with incomplete housing must be shielded against EMC emission by professionals according to local EMC provisions.

DA - Dansk

Sikkerhed

Læs sikkerhedsanvisningerne, før kameraet bruges. Overhold alle advarsler. Brug kun kameraet som anført i [Intended use](#) på side 50.



FORSIGTIG

Forbrændingsfare

Når kameraet bruges, kan det blive meget varmt og forårsage forbrændinger.



FORSIGTIG

Kvæstelser, hvis kameraet eller linser falder ned

Falder kameraet eller linsen ned, kan dette forårsage kvæstelser.



FORSIGTIG

Fare for skarpe kanter

Produktet kan have skarpe kanter.

Tilsluttet brug

Allied Vision produktets tilsluttede brug er en indbygning i et visionssystem, udført af fagfolk. Alle Allied Vision produkter sælges i B2B.

Kameraer uden lukket hus

Kameraer uden hus eller uden komplet hus skal beskyttes mod EMC emissioner iht. lokale EMC bestemmelser.

DE - Deutsch

Sicherheit

Bevor Sie die Kamera benutzen, lesen Sie diese Sicherheitshinweise. Beachten Sie diese Hinweise immer. Verwenden Sie die Kamera nur wie beschrieben in [Intended use](#) auf Seite 50.



VORSICHT

Gefahr von Verbrennungen

Im Betrieb kann die Kamera Temperaturen erreichen, die zu Verbrennungen führen.



VORSICHT

Verletzung durch fallende Kameras oder Objektive

Eine fallende Kamera oder ein fallendes Objektiv kann Verletzungen verursachen.



VORSICHT

Schnitte durch scharfe Kanten

Das Produkt kann scharfe Kanten haben.

Bestimmungsgemäßer Gebrauch

Allied Vision Produkte sind bestimmt für die Integration in Bildverarbeitungssysteme durch Fachpersonal. Alle Allied Vision Produkte werden in einer B2B-Umgebung verkauft.

Kameras ohne geschlossenes Gehäuse

Für Kameras ohne Gehäuse oder mit unvollständigem Gehäuse muss die Abschirmung gegen EMV-Emissionen gemäß den örtlichen EMV-Bestimmungen durchgeführt werden.

ES - Español

Seguridad

Antes de utilizar la cámara lea estas instrucciones de seguridad. Observe las advertencias en todo momento. Utilice la cámara solo tal y como se estipula en el [Intended use](#) en la página 50.



ATENCIÓN

Riesgo de quemaduras

Una cámara en funcionamiento puede alcanzar temperaturas que podrían provocar quemaduras.



ATENCIÓN

Lesiones en caso de que las cámaras o las lentes se caigan

Si una cámara o una lente se cae puede provocar lesiones.



ATENCIÓN

Riesgo de cortes por bordes afilados

El producto puede tener bordes afilados.

Uso previsto

El uso previsto del producto Allied Vision es la integración en el sistema de visión por parte de profesionales. Todos los productos Allied Vision se venden dentro de una relación B2B.

Cámaras sin carcasa cerrada

Las cámaras sin carcasa o con una carcasa incompleta deben protegerse contra las emisiones CEM por parte de profesionales de acuerdo con las disposiciones locales sobre la CEM.

FI - Suomi

Turvallisuus

Lue nämä turvallisuusohjeet ennen kameran käyttöä. Noudata varoituksia joka hetki. Käytä kameraa ainoastaan kohdassa [Intended use](#) sivulla 50 kuvatulla tavalla.



HUOMIO

Palovammojen vaara

Käytössä olevan kameran saavuttamat lämpötilatasot voivat aiheuttaa palovammoja.



HUOMIO

Putoavien kameroiden tai linssien aiheuttamat vammat

Putoava kamera tai linssi voi aiheuttaa vammoja.



HUOMIO

Terävien reunojen aiheuttama viiltovaara

Tuotteessa voi olla teräviä reunoja.

Käyttötarkoitus

Allied Vision-tuotteen käyttötarkoitus on integrointi kuvajärjestelmiin ammattilaisten toimesta. Kaikki Allied Vision-tuotteet myydään B2B-ympäristössä.

Kamerat, joissa ei ole suljettuja koteloita

Ammattilaisten on suojattava kamerat, joissa ei ole koteloa tai joiden kotelo on epätäydellinen, EMC-päästöiltä paikallisten EMC-määräysten mukaisesti.

FR - Français

Sécurité

Veillez lire ces consignes de sécurité avant d'utiliser la caméra. Respectez continuellement les avertissements. Utilisez la caméra uniquement comme indiqué sous [Intended use](#), page 50.



ATTENTION

Risque de brûlures

Une caméra en service peut atteindre des niveaux de température susceptibles d'entraîner des brûlures.



ATTENTION

Blessures en cas de chute de caméras ou d'objectifs

La chute d'une caméra ou d'un objectif peut entraîner des blessures.



ATTENTION

Risque de coupures sur des bords tranchants

Le produit peut présenter des bords tranchants.

Utilisation prévue

L'utilisation prévue du produit Allied Vision est son intégration dans des systèmes de vision par le soin de professionnels. Tout produit Allied Vision est vendu dans un cadre B2B.

Caméras sans boîtier fermé

Les caméras sans boîtier fermé ou à boîtier incomplet doivent être blindées contre les émissions CEM par le soin de professionnels conformément aux dispositions CEM locales.

עברית - HE

בטיחות

לפני השימוש במצלמה, עליך לקרוא את הוראות הביטחון האלו. עליך לממש הוראות ביטחון אלו תמיד. השימוש במצלמה הוא רק לפי מה שכתוב ב"כוונת השימוש" (Intended use) בעמוד 50.

זהירות

סכנת כוויה

בזמן הפערת המצלמה עלולות טמפרטורות גבוהות לעלות, שיכולות לגרום לכוויות.



זהירות

פגיעה מנפילת מצלמות או עדשות

מצלמה או עדשה שנופלות עלולות לגרום לפגיעה.



זהירות

סכנת חתכים על ידי קצוות חדים

למוצר יכולים להיות קצוות חדים.



שימוש מיועד

מוצרי AlliedVision מיועדים לשילוב במערכות ממוחשבת לעיבוד צילומים ע"י אנשי מקצוע. כל מוצרי AlliedVision נמכרים לשימוש בסביבת B2B.

מצלמות ללא מארז סגור

מצלמות ללא מארז, או עם מארז חלקי בלבד, חייבות להיות מוגנות בפני קרינה אלקטרומגנטית (EMC) על ידי אנשי מקצוע בהתאם לתקנים המקומיים (EMC).

IT - Italiano

Sicurezza

Leggere queste istruzioni per la sicurezza prima di utilizzare la telecamera. Osservare sempre tutte le avvertenze. Utilizzare la telecamera come descritto alla sezione [Intended use](#) a pagina 50.



ATTENZIONE

Pericolo di ustioni

Durante il funzionamento una telecamera può raggiungere temperature elevate che possono essere causa di ustioni.



ATTENZIONE

Lesioni dovute alla caduta di telecamere o lenti

La caduta di una telecamera o di una lente può causare delle lesioni.



ATTENZIONE

Pericolo di tagliarsi sui bordi affilati

I bordi del prodotto lente possono essere affilati.

Uso previsto

Il prodotto Allied Vision è concepito per essere integrato in sistemi di monitoraggio in campo professionale. Tutti i prodotti Allied Vision sono venduti in uno scenario B2B.

Telecamere senza custodia chiusa

Le telecamere senza custodia o con una custodia incompleta devono essere protette dalle emissioni elettromagnetiche in ambienti professionali in conformità con le norme CEM nazionali.

JA - 日本語

安全性

本カメラを使用する前に、この安全の手引きをお読みください。常に、警告事項を守ってください。必ず、[Intended use](#) 50 ページの通りに、本カメラを使用してください。



注意

やけどの危険性

作動中のカメラは、やけどを引き起こす温度まで熱くなる恐れがあります。



注意

カメラまたはレンズの落下によるけが

カメラまたはレンズが落下すると、けがをする恐れがあります。



注意

な端部で切り傷の危険性

本製品には鋭利な部分がある場合があります。

用途

Allied Vision製品は、専門家が視覚装置に統合することを意図したものです。すべてのAllied Vision製品は、企業間取り引き用に販売されています。

ハウジングで閉じられていないカメラ

ハウジングのないカメラまたはハウジングが不完全なカメラは、現地の電磁両立性 (EMC) 規定に従い、専門家によって、EMCエミッションから保護される必要があります。

NL - Nederlands

Veiligheid

Lees deze veiligheidsinstructies voordat u de camera gaat gebruiken. Neem deze waarschuwingen altijd in acht. Gebruik de camera uitsluitend, zoals aangegeven in het [Intended use](#) op pagina 50.



VOORZICHTIG

Risico van verbranding

Een camera die gebruikt wordt, kan temperatuurwaarden bereiken die brandwonden kunnen veroorzaken.



VOORZICHTIG

Letsel door vallende camera's of lenzen

Een vallende camera of lens kan letsel veroorzaken.



VOORZICHTIG

Risico van snijwonden door scherpe randen

Het product kan scherpe randen hebben.

Beoogd gebruik

Het beoogde gebruik van het Allied Vision-product is de integratie in optische systemen door professionals. Alle Allied Vision-producten worden verkocht in de B2B-markt.

Camera's zonder gesloten behuizing

Camera's zonder behuizing of met een onvolledige behuizing moeten door professionals worden beschermd tegen EMC-straling door EMC-beschermingen ter plaatse.

NO - Norsk

Sikkerhet

Les disse sikkerhetsinstruksene før du bruker kameraet. Følg advarslene til en hver tid. Bruk kun kameraet i samsvar med [Intended use](#) på side 50.



FORSIKTIG

Risiko for brannskader

Et kamera i bruk kan nå temperaturnivåer som kan forårsake brannskader.



FORSIKTIG

Skade ved fallende kameraer eller linser

Et fallende kamera eller en fallende linse kan forårsake skade.



FORSIKTIG

Risiko for kutt fra skarpe kanter

Produktet kan ha skarpe kanter.

Tiltenkt bruk

Den tiltenkte bruken av Allied Vision-produktet er integrering i visjonssystemer av profesjonelle. Alle Allied Vision-produkter selges i en forretning til forretning-situasjon.

Kameraer uten lukkede kamerahus

Kameraer uten kamerahus eller med ufullstendige kamerahus må beskyttes mot EMC-utslipp av fagfolk i henhold til lokale EMC-bestemmelser.

SV - Svenska

Säkerhet

Läs igenom säkerhetsinstruktionerna innan du använder kameran. Var hela tiden särskilt uppmärksam på varningarna. Använd enbart kameran på det sätt som anges i [Intended use](#) på sida 50.



VARNING

Risk för brännskada

En kamera i drift kan komma upp i temperaturer som kan orsaka brännskador.



VARNING

Risk för skador från fallande kameror eller objektiv

Fallande kameror eller objektiv kan förorsaka skador.



VARNING

Risk för skärsår från vassa kanter

Produkten kan ha vassa kanter.

Avsedd användning

Den avsedda användningen av Allied Vision-produkter är integrering i visionssystem av fackmän. Samtliga Allied Vision-produkter säljs i en B2B-miljö.

Kameror utan slutna kamerahus

Kameror utan eller med ofullständiga kamerahus måste skyddas mot elektromagnetiska emissioner av fackmän enligt lokala bestämmelser för elektromagnetiska emissioner.

ZH - 简体中文版

安全需知

使用本相机前，请阅读本安全说明书。请务必遵守相关警告和 [Intended use](#) 于第 50 页。



注意事项

烫伤风险

相机操作过程中温度可能上升并导致烫伤风险。



注意事项

相机或者镜头跌落造成伤害

相机或者镜头可能会跌落并造成伤害。



注意事项

锋利边缘割伤的风险

产品可能有锋利的边缘。

预期用途

Allied Vision 产品的预期用途是由专业人士整合到视觉系统中。所有 Allied Vision 的产品均通过 B2B 渠道销售。

无封闭式外壳相机

使用不带外壳或外壳不完整的相机时，必须由专业人员根据当地的 EMC 规定，对其进行 EMC 屏蔽。

Alvium CSI-2 cameras at a glance



Get an overview of Alvium CSI-2 camera documentation:

Notes	16
Consider for Alvium CSI-2 cameras.....	16
Shipping contents.....	16
What else do you need?	17
Alvium FP3/GM2- extending CSI-2	18
Alvium Flex- more flexibility	19
Alvium Frame- use your own optical mount	21

Notes



Read this document carefully

Learn to avoid damage to your Alvium CSI-2 camera and use it in the most safe and efficient way.



NOTICE

Damage to camera and embedded hardware by improper handling

Setup and operation for Alvium CSI-2 cameras in embedded systems is different than for cameras in PC-based systems. Components can easily be damaged.

- If you are unfamiliar with embedded systems, be extremely careful.
- Follow the safety notes.
- Follow the instructions in [Installing the hardware](#) on page 231.

Consider for Alvium CSI-2 cameras

Please read the following to better understand your Alvium CSI-2 camera and to setup your application smoothly:

- **Direct Register Access, Video4Linux Access, GenICam for CSI-2 Access:** [Access modes](#) on page 226
- [Exposure time and frame rates](#) on page 66
- Alvium CSI-2 characteristics: [Performance](#) on page 270
- [User sets](#) on page 207, including supported features, also for triggering
- [Bare board cameras](#) on page 232.



Vimba X

We recommend you to use **Vimba X** to enable the full feature range and proper operation.

Vimba X Firmware Updater included in **Vimba X** can be used to update any firmware version.

You can download **Vimba X** from www.alliedvision.com/en/products/software/vimba-x-sdk.



Maximum frame rates with SensorBitDepth

Alvium 1800 C models that support **SensorBitDepth** can run higher frame rates than with ADC bit depth. These values will be added for 1800 C-030 VSWIR, -040, -052, -130 VSWIR, -158, -240, -291, -508 in a future version of this document.

Shipping contents

- Alvium CSI-2 camera
- Download Instructions for First Camera Operation document

What else do you need?

This is a selection of helpful downloads:



	Download	Link
Controls and features		
	Alvium CSI-2 Register Controls Reference	www.alliedvision.com/en/support/technical-documentation/alvium-csi-2-documentation
	Alvium Features Reference	www.alliedvision.com/en/support/technical-documentation/alvium-csi-2-documentation
Applications		
	Application notes	www.alliedvision.com/en/support/technical-documentation/alvium-csi-2-documentation
Software downloads		
	Driver for Alvium CSI-2 cameras, code examples, and more	www.alliedvision.com/en/products/software/embedded-software-and-drivers
	Vimba X SDK for Windows, Linux, and Linux/ARM, including Vimba X Viewer, Firmware Updater, and Driver Installer for Windows	www.alliedvision.com/en/products/software/vimba-x-sdk
Firmware update		
	Firmware downloads	www.alliedvision.com/en/support/firmware-downloads
Accessories		
	Accessories , such as interface cables and cards, power and I/O cables, power supplies, lenses, and tripod adapters	www.alliedvision.com/en/products/accessories
STEP files		
	STEP files for standard models	Find downloads for your Alvium CSI-2 model at www.alliedvision.com/en/camera-selector
	Assembling Standard Alvium or Alvium Frame and Flex Cameras from CAD Components (application note)	www.alliedvision.com/en/support/technical-documentation/alvium-csi-2-documentation

Table 1: Downloads for Alvium CSI-2 cameras

Alvium FP3/GM2 - extending CSI-2

Alvium FP3/GM2 cameras extend the range of applications for Alvium CSI-2.



Figure 1: Alvium FP3 or Alvium GM2 camera

Interface cable length

Alvium 1500 C and 1800 C cameras support a maximum cable length of 420 mm for FPC cables connecting to the MIPI CSI-2 interface. Alvium FP3 and Alvium GM2 cameras enable vision applications with cable lengths up to **10 m for STP** and up to **15 m for Coax models**.

Housing options

Alvium 1500 C and 1800 C are available as bare board and open housing with C-Mount, CS-Mount, or S-Mount. Alvium FP3/GM2 cameras are offered as **closed housing** with the same lens mount options.

Supported sensor models

Every CSI-2 model is offered as FP3/GM2. For example, analog to Alvium 1800 C-240, Alvium FP3-240 and Alvium GM2-240 models are available.

Controls and features

Alvium FP3/GM2 cameras support **the same** V4L2 controls or GenICam features as 1500 C or 1800 C.

Hardware components

Alvium FP3/GM2 cameras, with an on-board serializer, connect to deserializer boards by FAKRA coaxial cables or by HSD STP cables. Deserializer boards connect to adapter boards or embedded boards by FPC cables.

Documentation

The **Alvium CSI-2 Cameras User Guide** is the basic reference for Alvium FP3/GM2, for all properties shared with Alvium 1500 C and 1800 C.

In addition, the **Alvium FP3/GM2 User Guide** provides:

- Differences in specifications
- Instructions for basic operation
- Interface descriptions.



Alvium FP3/GM2 User Guide and accessories

You can find the Alvium FP3/GM2 User Guide at www.alliedvision.com/en/support/technical-documentation/alvium-csi-2-documentation/.

For deserializer boards, FAKRA coaxial cables or STP cables, for adapter boards and FPC cables, see www.alliedvision.com/en/products/accessories.

Alvium Flex - more flexibility

Hardware options for standard Alvium cameras support various digital interfaces, housings, and lens mounts to enable a wide range of applications.

You have found that Alvium CSI-2 cameras with Hirose FH55-22S-0.5SH FPC connector do not offer enough flexibility for your application? You want to use your own cables and connectors?

Alvium Flex cameras with Hirose DF40C-50DP-0.4V board-to-board connector enable individual connections. Alvium Flex accessories can be used for developing and first testing. [Figure 2](#) shows how Add-on Boards connect to Alvium Flex cameras.

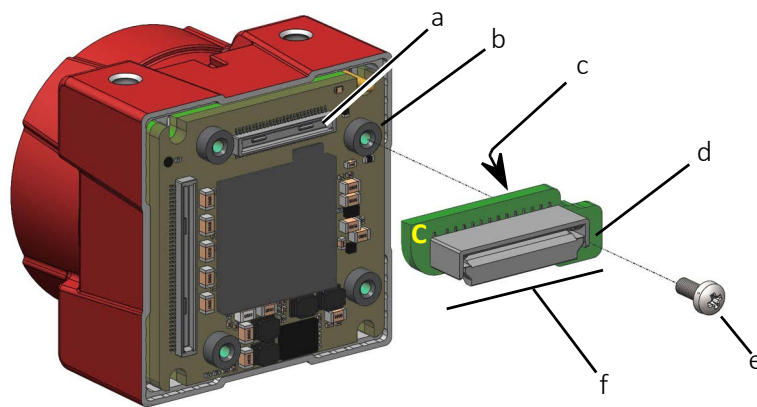

Figure 2: Alvium Flex camera, Interface Board, and screw

- a: Hirose DF40C-50DP-0.4V camera connector
- b: Mounting thread
- c: Hirose DF40C-50DS-0.4V board connector
- d: Mounting hole
- e: Fastening screw
- f: Add-on Board

Alvium CSI-2 Flex

The following options are offered for **Alvium CSI-2 Flex** cameras. Above developing and testing, Alvium Flex adds flexibility to **standard Alvium CSI-2** cameras.

Individual solutions

Hirose DF40 board-to-board connector enables individual connections to your own boards and cables.

Off-the-shelf solution

Alvium CSI-2 Flex accessories enhance existing applications based on Hirose FH55 connector. As an alternative, the Add-on Board with a Hirose TF38 connector can be used. It connects the cable tightly and perpendicular to the camera back plane. For the setup shown in [Figure 3](#), FPC cables connect in a straight line without bending:

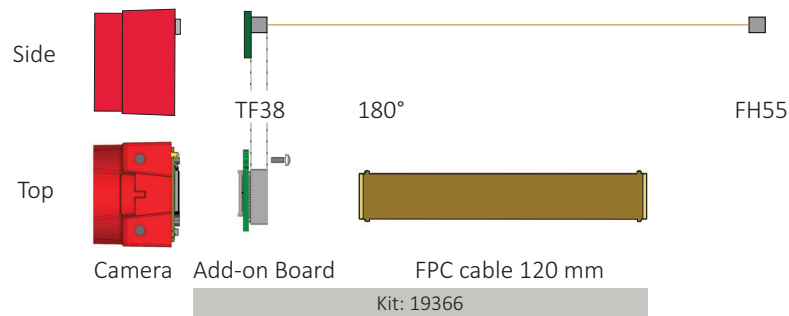

Figure 3: **Alvium CSI-2 Flex** camera connection

Alvium Flex cameras

See contents in [Specifications](#) on page 60 and in [Camera interfaces](#) on page 246.



Alvium Flex accessories and instructions

See the Alvium Flex Design and Accessory Guide at www.alliedvision.com/en/support/technical-documentation/alvium-csi-2-documentation.



Ordering Alvium Flex cameras

See the Alvium Modular Concept at www.alliedvision.com/en/support/technical-documentation/alvium-csi-2-documentation.



Alvium Frame Flex

You can combine hardware options for Alvium CSI-2 Frame Flex cameras.

Alvium Frame - use your own optical mount

You want to design your own lens mount for Alvium CSI-2 cameras or your application does not need a lens mount? In this case, Alvium Frame adds more flexibility. The square front flange with only 10 mm depth aligns to your individual housing with an extremely high accuracy.

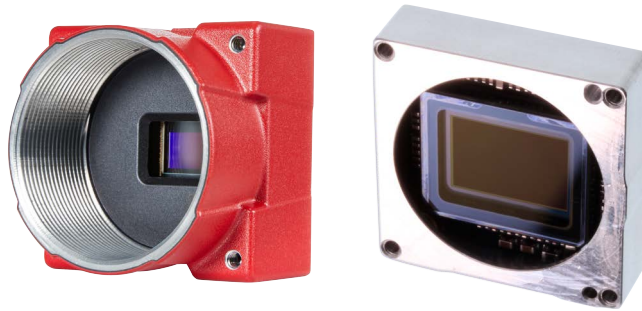

Figure 4: Standard Alvium CSI-2 open housing (left) vs. Alvium CSI-2 Frame (right)

Specifications

- [Alvium Frame: Dimensions and mass](#) on page 200
- [Alvium Frame: Technical drawings](#) on page 200
- [Housed Alvium Frame: Sensor shift and rotation](#) on page 205

Instructions

- [Installing Alvium Frame](#) on page 239
- [Aligning the sensor with your optical system](#) on page 240
- [Mounting Alvium Frame](#) on page 241



Ordering Alvium Frame cameras

See the Alvium Modular Concept at www.alliedvision.com/en/support/technical-documentation/alvium-csi-2-documentation.



Alvium Frame Flex

You can combine hardware options for Alvium CSI-2 Frame Flex cameras.

Contact us

Website, email

General

www.alliedvision.com/en/contact
info@alliedvision.com

Distribution partners

www.alliedvision.com/en/avt-locations/avt-distributors

Support

www.alliedvision.com/en/support
www.alliedvision.com/en/about-us/contact-us/technical-support-repair-/-rma

Offices

Europe, Middle East, and Africa (Headquarters)

Allied Vision Technologies GmbH
Taschenweg 2a
07646 Stadtroda, Germany
T// +49 36428 677-0 (Reception)
T// +49 36428 677-230 (Sales)
F// +49 36428 677-28

Asia-Pacific

China

Allied Vision Technologies
(Shanghai) Co., Ltd.
2-2109 Hongwell Int. Plaza
1602# ZhongShanXi Road
Shanghai 200235, China
T// +86 21 64861133

Singapore

Allied Vision Technologies Asia Pte. Ltd
82 Playfair Rd, #07-01 D'Lithium
Singapore 368001
T// +65 6634 9027

North, Central, and South America

Canada

Allied Vision Technologies Canada Inc.
300 – 4621 Canada Way
Burnaby, BC V5G 4X8, Canada
T// +1 604 875 8855

USA

Allied Vision Technologies, Inc.
102 Pickering Way- Suite 502
Exton, PA 19341, USA
Toll-free// +1-877-USA-1394
T// +1 978 225 2030

Contents

Read before use	2
EN - English	2
DA - Dansk	3
DE - Deutsch	4
ES - Español	5
FI - Suomi	6
FR - Français	7
HE - עברית	8
IT - Italiano	9
JA - 日本語	10
NL - Nederlands	11
NO - Norsk	12
SV - Svenska	13
ZH - 简体中文版	14
Alvium CSI-2 cameras at a glance	15
Notes	16
Consider for Alvium CSI-2 cameras	16
Shipping contents	16
What else do you need?	17
Alvium FP3/GM2 - extending CSI-2	18
Alvium Flex - more flexibility	19
Alvium CSI-2 Flex	19
Individual solutions	19
Off-the-shelf solution	20
Alvium Frame - use your own optical mount	21
Specifications	21
Instructions	21
Contact us	22
Document history and conventions	31
Document history	32
Conventions used in this user guide	43
Typographic styles	43
Symbols and notes	44
GenICam for CSI-2 Access	45
Naming and terms	45
Controls and features	45
ROI and cropping	46
Camera model naming	46
Terms and acronyms	46
Compliance, safety, and intended use	48
Camera identification	49

Compliance notifications	49
Bare board and open housing cameras	50
Avoid electromagnetic interferences	50
Intended use	50
Copyright and trademarks	51
Your safety	51
Handling lens mounts and Alvium Frame	51
Housed cameras: handling hot cameras	51
Providing optimum heat dissipation	52
Camera mounting	53
Heavy lenses	53
Product safety	53
Embedded systems	53
Supported embedded boards	53
Electrical connections	54
ESD	54
Cable connections	54
PCBAs	54
Camera power	55
Ground loops	55
Hirose FH55 and DF40C-50DP-0.4V connectors	55
Hirose FH 55 FPC connectors	56
MIPI CSI-2 FPC cables	56
Handling bare board cameras	57
Optical components	57
Sensor	58
Lenses	59
Mechanical components	59
Heat sinks	59
Conductive media for heat sinks	59
Specifications	60
Applied standards	61
GenICam	61
MIPI CSI-2	61
V4L2	61
Shock and vibration	61
IEC 60068-2-6: Sinusoidal vibration	62
IEC 60068-2-27: Shock	63
IEC 60068-2-64: Random vibration	63
Notes on specifications	64
Sensor	64
Absolute QE plots	64
Spectral response plots	64
Pixel format default and naming	65
GenICam for CSI-2 Access	65
Other access modes	65
Pixel formats for various standards	65
Exposure time and frame rates	66

Achieved values deviating from specified values	66
CSI-2LaneCount and CSI-2ClockFrequency	66
Dropped frames or a viewer issue?	66
Frame rates with ROI/Cropping	66
Readout modes to reduce the bandwidth	67
Exposure time behavior regarding ExposureMode.	67
Operation for maximum frame rates	68
Frame rates with rolling shutter sensors	69
Sensor shutter types.	69
Digital binning	70
Sensor binning.	70
Operation for medium power consumption	70
Dimensions and mass.	70
Alvium 1500 C model specifications	71
Alvium 1500 C-050m/c.	71
Absolute QE	73
Spectral response.	73
Frame rates with Cropping	74
Alvium 1500 C-120m/c.	75
Absolute QE	77
Spectral response.	77
Frame rates with Cropping	78
Alvium 1500 C-210m/c.	79
Absolute QE	81
Spectral response.	81
Frame rates with Cropping	82
Alvium 1500 C-500m/c.	83
Absolute QE	85
Spectral response.	85
Frame rates with Cropping	86
Alvium 1500 C-501m/c NIR	87
Absolute QE	89
Spectral response.	89
Frame rates with Cropping	90
Alvium 1800 C model specifications	91
Alvium 1800 C-030 VSWIR	91
Relative QE	92
Frame rates with Cropping	93
Alvium 1800 C-040m/c.	94
Absolute QE	96
Spectral response.	96
Frame rates with Cropping	97
Alvium 1800 C-052m/c.	98
Absolute QE, spectral response	99
Frame rates with Cropping	100
Alvium 1800 C-130 VSWIR	101
Relative QE	102
Frame rates with Cropping	103

Alvium 1800 C-158m/c.....	104
Absolute QE	106
Spectral response.....	106
Frame rates with Cropping	107
Alvium 1800 C-203m/c.....	108
Absolute QE, spectral response	109
ROI frame rates	110
Alvium 1800 C-234m/c.....	111
Absolute QE	113
Spectral response.....	113
ROI frame rates	114
Alvium 1800 C-235m/c.....	115
Absolute QE	117
Spectral response.....	117
ROI frame rates	118
Alvium 1800 C-240m/c.....	119
Absolute QE	121
Spectral response	121
Frame rates with Cropping	122
Alvium 1800 C-291m/c.....	123
Absolute QE, spectral response	124
Frame rates with Cropping	125
Alvium 1800 C-319m/c.....	126
Absolute QE	128
Spectral response.....	128
Frame rates with Cropping	129
Alvium 1800 C-500m/c.....	130
Absolute QE	132
Spectral response.....	132
Frame rates with Cropping	133
Alvium 1800 C-507m/c.....	134
Absolute QE	136
Spectral response.....	136
Frame rates with Cropping	137
Alvium 1800 C-508m/c.....	138
Absolute QE	140
Spectral response.....	140
Frame rates with Cropping	141
Alvium 1800 C-510m/c.....	142
Absolute QE	144
Spectral response.....	144
Frame rates with Cropping	145
Alvium 1800 C-511m/c.....	146
Absolute QE	148
Spectral response.....	148
Frame rates with Cropping	149
Alvium 1800 C-811m/c.....	150
Absolute QE	152

Spectral response	152
Frame rates with Cropping	153
Alvium 1800 C-812 UV	154
Absolute QE	155
Spectral response	155
Frame rates with Cropping	156
Alvium 1800 C-895m/c	157
Absolute QE	158
Spectral response	158
Frame rates with Cropping	159
Alvium 1800 C-1236m/c	160
Absolute QE	162
Spectral response	162
Frame rates with Cropping	163
Alvium 1800 C-1240m/c	164
Absolute QE	166
Spectral response	166
Frame rates with Cropping	167
Alvium 1800 C-1242m/c	168
Absolute QE	170
Spectral response	170
Frame rates with Cropping	171
Alvium 1800 C-1620m/c	172
Absolute QE	174
Spectral response	174
Frame rates with Cropping	175
Alvium 1800 C-2040m/c	176
Absolute QE	178
Spectral response	178
Frame rates with Cropping	179
Alvium 1800 C-2050m/c	180
Absolute QE	182
Spectral response	182
Frame rates with Cropping	183
Alvium 1800 C-2460m/c	184
Absolute QE	186
Spectral response	186
Frame rates with Cropping	187
White balance default	188
Standard Alvium: Dimensions and mass	189
Standard Alvium: Technical drawings	190
Bare Board (standard Alvium)	190
Open Housing C-Mount (standard Alvium)	192
Open Housing CS-Mount (standard Alvium)	193
Open Housing S-Mount (standard Alvium)	194
Alvium Flex: Dimensions and mass	195
Alvium Flex: Technical drawings	195
Bare Board (Alvium Flex)	196

Open Housing C-Mount (Alvium Flex)	197
Open Housing CS-Mount (Alvium Flex)	198
Open Housing S-Mount (Alvium Flex)	199
Alvium Frame: Dimensions and mass	200
Alvium Frame: Technical drawings	200
Alvium Frame Flex: Dimensions and mass	201
Alvium Frame Flex: Technical drawings.	201
Maximum protrusion for front mounts.	202
IR cut filter	203
Sensor position accuracy	204
Housed standard and Flex cameras: Sensor shift and rotation	204
Housed Alvium Frame: Sensor shift and rotation	205
All housed Alvium CSI-2 cameras: Sensor tilt	205
User sets.	207
Supported features.	207
Trigger features and UserSetDefault.	207
Camera feature availability.	208
Lenses: Focal length vs. field of view	210
About this chapter.	211
Parameters in tables.	211
Optical vignetting with certain lenses	211
About S-Mount lenses.	212
Focal length vs. field of view	212
Alvium 1500 C-050m/c.	212
Alvium 1500 C-120m/c.	213
Alvium 1500 C-210m/c.	213
Alvium 1500 C-500m/c, 1500 C-501m/c NIR	214
Alvium 1800 C-030 VSWIR	214
Alvium 1800 C-040m/c.	215
Alvium 1800 C-052m/c.	215
Alvium 1800 C-130 VSWIR	216
Alvium 1800 C-158m/c.	216
Alvium 1800 C-203m/c.	217
Alvium 1800 C-234m/c, 1800 C-235m/c.	217
Alvium 1800 C-240m/c.	218
Alvium 1800 C-291m/c.	218
Alvium 1800 C-319m/c.	219
Alvium 1800 C-500m/c.	219
Alvium 1800 C-507m/c, 1800 C-508m/c.	220
Alvium 1800 C-510m/c, 1800 C-511m/c.	220
Alvium 1800 C-811m/c, 1800 C-812 UV	221
Alvium 1800 C-895m/c.	221
Alvium 1800 C-1236m/c.	222
Alvium 1800 C-1240m/c.	222
Alvium 1800 C-1242m/c.	223
Alvium 1800 C-1620m/c.	223
Alvium 1800 C-2040m/c.	224
Alvium 1800 C-2050m/c.	224

Alvium 1800 C-2460m/c.....	225
Access modes	226
Overview	227
Notes on GenICam for CSI-2 Access	227
Data flow	228
V4L2 controls and register controls.....	229
GenICam features	229
GenICam for CSI-2 Access - Camera operation.....	230
Need to restart the embedded board.....	230
Debouncer.....	230
Device reset.....	230
User sets	230
Installing the hardware	231
Touching hot cameras.....	232
Sensor damage by ESD	232
Scope of instructions.....	232
Software installation.....	232
Hardware installation.....	232
Bare board cameras	232
Serial numbers of Alvium® chips and bare board cameras.....	233
Connecting FPC cable and FPC connectors.....	234
Mounting the heat sink.....	236
Mounting the camera	237
Mounting bare board cameras	237
Mounting open housing cameras	238
Bottom or top mounting	238
Front mounting.....	239
Installing Alvium Frame	239
Aligning the sensor with your optical system	240
Mounting Alvium Frame	241
Adapting maximum torque values	242
Mounting the lens.....	242
Mounting and focusing S-Mount lenses.....	243
Camera interfaces	246
Standard Alvium and Alvium Frame: Connections.....	247
Recommended accessories	247
Back panel	247
Hirose FH55 connector pin assignment	248
Alvium Flex: Connections	250
Observe for DF40C-50DP-0.4V connectors	250
Back panel	250
DF40C-50DP-0.4V connector details.....	250
All Alvium CSI-2: Connections.....	253
I/O use for UART.....	253
Non-isolated, programmable GPIOs	254
GPIOs description.....	254

Input levels	255
Output levels	255
Status LED	256
Normal operation	256
Error conditions	256
Triggering	257
Availability of triggering controls for CSI-2	258
Trigger signal flow	258
Trigger latency	259
Trigger features and UserSetDefault	259
Triggering with rolling shutter cameras	259
Ignored triggers	261
Trigger delay with 1500 C-120 cameras	261
Firmware update	262
Please note	263
Preparing firmware updates	263
Updating the firmware	264
Error handling	266
Image data flow	267
Performance	270
Image transfer with rolling shutter cameras	271
Frame rate jitter	271
Value changes by control interdependencies	272
Effects for the interdependent controls	273
Impact by other controls	273
Exposure times and frame rates with Sony IMX rolling shutter cameras	273
Dark current compensation	274
Additional compensation	275
Black level compensation for 1500 C-050m/c	275
Shutter types affecting image readout	276
Index	277

Document history and conventions



This chapter includes:

Document history	32
Conventions used in this user guide.....	43
Naming and terms	45

Document history

Version	Date	Remarks
V3.5.1	2023-12-13	<p>Firmware version: 00.13.00.e83c9689</p> <ul style="list-style-type: none"> Updated firmware version to FW 00.13.00.e83c9689. FW 00.13.00.849ffda0 was never released. Added notes that bare board cameras must be aligned by the user in Specifications on page 60 and in Installing the hardware on page 231.
V3.5.0	2023-Dec-04	<p>Release: Firmware version: 00.13.00.e83c9689 FW 00.13.00.849ffda0 stated for this document version was never released.</p> <ul style="list-style-type: none"> Updated table for Frame rates with rolling shutter sensors on page 69. Extended information on Sensor binning on page 70. Different from other Alvium series, frame rates in Specifications on page 60 are calculated, not measured. The stated values are not affected by the change from FW V00.12 to FW V00.13. Added changes to Specifications on page 60: <ul style="list-style-type: none"> Removed 1800 C-131 and 1800 C-192 models, also from Lenses: Focal length vs. field of view on page 210. Changed width resolution for 1800 C-510 and -511 from 2472 to 2464 pixels in Alvium 1800 C model specifications on page 91. (The width resolution for these models is 2464 with all firmware versions. In earlier versions of this user guide, 2472 pixels were specified incorrectly.) Fixed errors with pixel formats in Alvium 1800 C model specifications on page 91: <ul style="list-style-type: none"> Added support for sensor binning for 1800 C-158m, -240m, -291m, and -508m. Removed Packed pixel formats (only supported by Alvium G1 and G5). Corrected color pixel formats for 1800 C-500 from RG to GR. Separated Raw color pixel formats from RGB color pixel formats. <p>Continued on next page.</p>

Table 2: Document history (sheet 1 of 12)

Version	Date	Remarks
V3.5.0	2023-Dec-04	<p>Release: Firmware version: 00.13.00.e83c9689</p> <p>Continued from previous page.</p> <ul style="list-style-type: none"> Added 8-bit readout for 1800 C-030 VSWIR in Alvium 1800 C model specifications on page 91. Updated Camera feature availability on page 208. Applied editorial changes.
V3.4.3	2023-Nov-01	<p>Firmware version: 00.12.00.00611a22</p> <p>Added contents to avoid permanent damage to the sensor by ESD:</p> <ul style="list-style-type: none"> Extended the note for ESD on page 54. Added Possible damage to image sensors due to electrostatic charge on page 58. Added a warning in Sensor damage by ESD on page 232 in the installation chapter.
V3.4.2	2023-Oct-25	<p>Firmware version: 00.12.00.00611a22</p> <p>Corrected frame rate values in the specs table for Alvium 1800 C-203m/c on page 108.</p>
V3.4.1	2023-Oct-04	<p>Firmware version: 00.12.00.00611a22</p> <p>Adjusted frame rate values for Alvium 1800 C-131m/c (coming soon) on page 102.</p>
V3.4.0	2023-Sep-27	<p>Firmware version: 00.12.00.00611a22</p> <ul style="list-style-type: none"> Added 1800 C-203 models in Specifications on page 60 and in Lenses: Focal length vs. field of view on page 210. Added 1800 C-131 and 1800 C-192 models (coming soon) in Specifications on page 60 and in Lenses: Focal length vs. field of view on page 210. Added 12-bit pixel formats in Specifications on page 60. Updated technical drawings for bare board and open housing cameras in Standard Alvium: Technical drawings on page 190. Updated Cooling area for Alvium CSI-2 bare board cameras on page 236. Updated Mounting area of Alvium CSI-2 bare board cameras connector side (left); sensor side (right) on page 238. Applied editorial changes.

Table 2: Document history (sheet 2 of 12)

Version	Date	Remarks
V3.3.2	2023-Aug-08	Firmware version: 00.12.00.00611a22 <ul style="list-style-type: none"> Updated references to coaxial cameras and connections by adding contents for STP. The Alvium FP3/GM2 Coax User Guide has been renamed to Alvium FP3/GM2 User Guide to include STP models. Changed status for Alvium Flex to available and updated product codes for Alvium Flex accessories in Alvium CSI-2 Flex on page 19. Changed status for Alvium Frame to available in Alvium Frame - use your own optical mount on page 21. Corrected values for length and mass for Alvium Frame: Dimensions and mass on page 200 and Alvium Frame Flex: Dimensions and mass on page 201. Added Global reset shutter (GRS) to 1800 C-1240 and 1800 C-2050 for shutter type in Specifications on page 60.
V3.3.1	2023-Jul-05	Firmware version: 00.12.00.00611a22 Changed horizontal resolution for 1800 C-510 and 1800 C-511 in Specifications on page 60.
V3.3.0	2023-Jun-14	Firmware version: 00.12.00.00611a22 <ul style="list-style-type: none"> Added 1800 C-895m/c models in Specifications on page 60 and in Lenses: Focal length vs. field of view on page 210. Applied editorial changes.

Table 2: Document history (sheet 3 of 12)

Version	Date	Remarks
V3.2.0	2023-Jun-06	<p>Release: Firmware version: 00.12.00.00611a22</p> <ul style="list-style-type: none"> Added safety notes for handling sharp edges of Alvium Frame cameras in Read before use on page 2, Handling lens mounts and Alvium Frame on page 51, and Installing Alvium Frame on page 239. Updated specifications for Alvium 1800 C cameras for GenICam for CSI-2 Access. Updated maximum frame rates for Alvium 1800 C-1620m/c on page 172 for a resolution of 5328 (H) × 3040 (V). Added data on sensor binning for selected models in Specifications on page 60, in Camera feature availability on page 208, and in Image data flow on page 267. Updated Serial numbers of Alvium® chips and bare board cameras on page 233.
V3.1.1	2023-Apr-21	<p>Firmware version: 00.11.00.9cf0c21e</p> <ul style="list-style-type: none"> Added note about Alvium FP3/GM2 Coax cameras on the title page. Added reference to Alvium FP3/GM2 Coax cameras in Alvium CSI-2 cameras at a glance on page 15.
V3.1.0	2023-Mar-30	<p>Firmware version: 00.11.00.9cf0c21e</p> <ul style="list-style-type: none"> Added contents for Alvium CSI-2 Frame in: <ul style="list-style-type: none"> Alvium CSI-2 cameras at a glance on page 15 Specifications on page 60 Installing Alvium Frame on page 239. Updated contents for Vimba X. Updated QE curves for 1800 C-030 VSWIR and 1800 C-130 VSWIR in Specifications on page 60. Reduced value for sensor shift with 1800 C-2050 models to 150 µm in Sensor position accuracy on page 204. Applied editorial changes.
V3.0.1	2023-Feb-28	<p>Firmware version: 00.11.00.9cf0c21e</p> <ul style="list-style-type: none"> Applied editorial changes to remove ugly page breaks. Added index markers.

Table 2: Document history (sheet 4 of 12)

Version	Date	Remarks
V3.0.0	2023-Feb-21	Firmware version: 00.11.00.9cf0c21e <ul style="list-style-type: none"> Updated Hebrew contents in Read before use on page 2. Corrected the width value in the specifications for Alvium 1800 C-1620m/c on page 172. Added contents for Alvium Flex - more flexibility on page 19, in Specifications on page 60, and in Camera interfaces on page 246. Updated schematics in Table 98: Standard Alvium and Alvium Frame - Hirose FH55-22S-0.5SH connector pin assignment on page 248. Updated Table 87: Bare Board (standard Alvium and Alvium Flex) model specific dimensions and nominal values on page 191. Updated Cooling area for Alvium CSI-2 bare board cameras on page 236. Updated contents in GenICam for CSI-2 Access - Camera operation on page 230. Applied editorial changes.
V2.9.1	2022-Nov-14	Firmware version: 00.11.00.9cf0c21e <ul style="list-style-type: none"> Added note that lenses are not part of the product. Applied editorial changes.
V2.9.0	2022-Oct-27	Release: Firmware version: 00.11.00.9cf0c21e <ul style="list-style-type: none"> Updated standard references in Applied standards on page 61. Updated ROI frame rates and exposure time ranges in Specifications on page 60. Added note on deviations from stated frame rates in Achieved values deviating from specified values on page 66. Updated various data for 1800 C-234m/c and 1800 C-235m/c models in Specifications on page 60. Added 1800 C-510m/c models in Specifications on page 60 and in Lenses: Focal length vs. field of view on page 210. Applied editorial changes.

Table 2: Document history (sheet 5 of 12)

Version	Date	Remarks
V2.8.4	2022-Oct-19	Firmware version: 00.10.00.6c9062b1 <ul style="list-style-type: none"> Added note to use Vimba 6.1 in Consider for Alvium CSI-2 cameras on page 16. Updated ROI frame rates for 1800 C-234m/c and 1800 C-235m/c models in Specifications on page 60. Added GenICam for CSI-2 Access to Alvium 1800 C-234 and 1800 C-235 models. Applied editorial changes.
V2.8.3	2022-Sep-20	Firmware version: 00.10.00.6c9062b1 <ul style="list-style-type: none"> Added Hebrew contents to Read before use on page 2. Changed units Gbps to Gbit/s and KB to KByte for clarity. Corrected data in Specifications on page 60: <ul style="list-style-type: none"> Max. gain for Alvium 1800 C-030 VSWIR and 1800 C-130 VSWIR was changed to 42 dB. Pixel formats for Alvium 1800 C-234 and 1800 C-235 were adjusted. Set all models to Available Removed FPNC availability for 1800 C-234 and 1800 C-235. Added a note in Image data flow on page 267 that 1800 C-234 and 1800 C-235 models currently do not support FPNC. Applied editorial changes.
V2.8.2	2022-Aug-05	Firmware version: 00.10.00.6c9062b1 Removed “Coming soon” status for Alvium 1800 C-812 UV on page 154.
V2.8.1	2022-Jul-22	Firmware version: 00.10.00.6c9062b1 <ul style="list-style-type: none"> Added values for minimum and maximum exposure times in Specifications on page 60. Corrected dimensions for screws from M2 to M1.6 in Mounting bare board cameras on page 237.

Table 2: Document history (sheet 6 of 12)

Version	Date	Remarks
V2.8.0	2022-Jul-20	<p>Release: Firmware version: 00.10.00.6c9062b1</p> <ul style="list-style-type: none"> Added Camera identification on page 49, including Model ID for DoC assignment. Updated data in Specifications on page 60: <ul style="list-style-type: none"> ROI frame rates and exposure time ranges Maximum gain for Sony IMX global shutter cameras increased to 48 dB. Added 1800 C-234m/c, 1800 C-235m/c, and 1800 C-812 UV models in Specifications on page 60 and in Lenses: Focal length vs. field of view on page 210. Updated values for Exposure Modes of Alvium 1800 C-511m/c on page 146. Added the information that Alvium 1800 C-511 is supplied on request only to Sensor position accuracy on page 204. Added Camera feature availability on page 208. Added warning against voltage levels of serial communication in Hirose FH55 connector pin assignment on page 248. Added I/O use for UART on page 253. Corrected pin assignment for non-isolated GND in Figure 101: GPIOs block diagram on page 254. Removed FPNC support for VSWIR models and added DPC support for Alvium 1800 C-052 and 1800 C-291 in Image data flow on page 267. Removed the section “Control value changes on a streaming camera” from Performance on page 270. Applied editorial changes.
V2.7.1	2022-Apr-12	<p>Firmware version: 00.08.00.6727174b</p> <ul style="list-style-type: none"> Added notes that Alvium 1800 C-052 and 1800 C-291 currently do not support DPC and FPNC to Image data flow on page 267. Applied editorial changes.

Table 2: Document history (sheet 7 of 12)

Version	Date	Remarks
V2.7.0	2022-Mar-17	<p>Release: Firmware version: 00.08.00.6727174b</p> <ul style="list-style-type: none"> Added contents for GenICam for CSI-2 Access at various places, including User sets on page 207. Renamed Alvium 1800 C-030m VSWIR to Alvium 1800 C-030 VSWIR, and Alvium 1800 C-130m VSWIR correspondingly. Updated conditions for Operation for maximum frame rates on page 68 and renamed Operation for medium power consumption on page 70. Updated exposure time ranges by model in Specifications on page 60. Added note about frame rates in triggered mode for Alvium 1500 C-120m/c on page 75. Added Alvium 1800 C-052m/c, 1800 C-291m/c, and 1800 C-500m/c to Alvium 1800 C model specifications on page 91. Added note for non-standard S-Mount hardware options in Sensor position accuracy on page 204. Updated the flow chart and added descriptions for GenICam for CSI-2 Access in Access modes on page 226. Added information on Ignored triggers on page 261. Updated workflow in Image data flow on page 267. Updated workflow in Value changes by control interdependencies on page 272. Applied editorial changes.
V2.6.2	2021-Dec-17	<p>Firmware version: 00.07.00.81db3896</p> <ul style="list-style-type: none"> Removed icon for compliance with UKCA in Compliance notifications on page 49. (The icon was previously added by mistake.) Removed information on Digital Binning because it is not supported by the current camera driver.
V2.6.1	2021-Nov-23	<p>Firmware version: 00.07.00.81db3896</p> <ul style="list-style-type: none"> Updated links to accessories. Applied minor editorial changes.

Table 2: Document history (sheet 8 of 12)

Version	Date	Remarks
V2.6.0	2021-Nov-03	<p>Release: Firmware version: 00.07.00.81db3896</p> <ul style="list-style-type: none"> Added 1800 C-030m VSWIR and 1800 C-130m VSWIR models in Specifications on page 60 and in Lenses: Focal length vs. field of view on page 210. Added Digital Binning on page 50. Updated the minimum temperature value for operation and storage from +5 °C to -20 °C. Updated workflow in Image data flow on page 267 for new Digital Binning. Updated diagram in Value changes by control interdependencies on page 272. Removed Limitations for available resolutions from Troubleshooting. Applied minor editorial changes.
V2.5.1	2021-Aug-12	<p>Firmware version: 00.06.00.35992</p> <ul style="list-style-type: none"> Added icon for compliance with UKCA in Compliance notifications on page 49. Applied minor editorial changes.
V2.5.0	2021-Aug-04	<p>Release: Firmware version: 00.06.00.35992</p> <ul style="list-style-type: none"> Added 1500 C-120 to Frame rate jitter on page 271 and Trigger delay with 1500 C-120 cameras on page 261. Added 1500 C-501m/c NIR model in Specifications on page 60. Added 1800 C-511m/c, 1800 C-811m/c, 1800 C-1242m/c, 1800 C-1620m/c, and 1800 C-2040m/c models in Specifications on page 60 and in Lenses: Focal length vs. field of view on page 210. Updated tables with ROI frame rates, including bandwidth per lane in Specifications on page 60. Reduced contents in Access modes on page 226 (previous title: V4L2 controls vs. GenICam features). Applied minor editorial changes.

Table 2: Document history (sheet 9 of 12)

Version	Date	Remarks
V2.4.0	2021-Apr-08	<p>Release: Firmware version: 00.04.00.34658</p> <ul style="list-style-type: none"> Added RAW pixel formats for 10-bit and 12-bit Mono in Specifications on page 60. Added 1800 C-2460m/c models in Specifications on page 60. Updated mass values in Standard Alvium: Dimensions and mass on page 189. Updated descriptions in Access modes on page 226. Updated instructions for Mounting the camera on page 237. Updated graphic in Value changes by control interdependencies on page 272. Applied minor editorial changes.
V2.3.0	2020-Dec-15	<p>Release: Firmware version: 00.03.00.31919</p> <ul style="list-style-type: none"> Updated ROI frame rates and values for minimum and maximum exposure time in Specifications on page 60. Added content about Pixel format default and naming on page 65. Added values for White balance default on page 188. Updated drawings and dimension values for bare board cameras in Standard Alvium: Technical drawings on page 190. Updated tables in Access modes on page 226. Added information about Serial numbers of Alvium® chips and bare board cameras on page 233. Added Non-isolated, programmable GPIOs on page 254. Added Triggering on page 257. In Image data flow on page 267, added FPNC support for all models, except for Alvium 1800 C-2050. Added notes about frame rates for rolling shutter cameras run in triggered mode. Added content about Limitations for available resolutions on page 201. Applied minor editorial changes.

Table 2: Document history (sheet 10 of 12)

Version	Date	Remarks
V2.2.0	2020-Jul-22	Release: Firmware version: 00.02.00.29974 <ul style="list-style-type: none"> Added Alvium 1800 C-240m/c, 1800 C-508m/c, and 1800 C-1240m/c models. Updated ROI frame rates and pixel formats in Specifications on page 60. Updated Type for Alvium 1500 C-210m/c on page 79. Added QE and spectral response to Alvium 1800 C-2050m/c on page 180. Extended information in Shock and vibration on page 61. Updated spectral response graphic in IR cut filter on page 203. Added Sensor position accuracy on page 204. Added Read before use on page 2. Corrected minor errors.
V2.1.3	2020-Mar-12	Firmware version: 00.01.03.29478 <ul style="list-style-type: none"> Corrected maximum exposure times. DPC: Removed specifications into an application note. FPNC: Updated note in Image data flow on page 267.
V2.1.2	2020-Mar-04	Firmware version: 00.01.03.29478 Applied minor changes.
V2.1.1	2020-Feb-28	Firmware version: 00.01.03.29478 Updated content for shutter types.
V2.1.0	2020-Feb-20	Release: Firmware version: 00.01.03.29478 <ul style="list-style-type: none"> Added Alvium 1800 C-319m/c, 1800 C-507m/c, 1800 C-1236m/c, and 1800 C-2050m/c models. Added specifications for DPC. Updated description for sensor shutter types.

Table 2: Document history (sheet 11 of 12)

Version	Date	Remarks
V2.0.0	2020-Jan-06	Release: Firmware version: 00.01.02.28100 <ul style="list-style-type: none"> Added Alvium 1500 C-210m/c, 1800 C-040m/c, and 1800 C-158m/c models. Added descriptions for Hue and Saturation in Access modes on page 226. Added Dark current compensation on page 274. Updated technical drawings and dimensions for bare board cameras in Standard Alvium: Dimensions and mass on page 189. Updated values for power consumption in Specifications on page 60. Restructured contents in Performance on page 270.
V1.1.0	2019-Jul-01	Firmware version: 00.01.00.26405 <ul style="list-style-type: none"> Removed separate bit depth for maximum frame rates in Specifications on page 60. Corrected ADC bit depth for Alvium 1500 C-500m/c in Specifications on page 60 and for all models in Image data flow on page 267.
V1.0.0	2019-Jun-04	Release: Firmware version: 00.01.00.26405 Release version

Table 2: Document history (sheet 12 of 12)

Conventions used in this user guide

To give this document an easily understood layout and to emphasize important information, the following typographical styles and symbols are used:

Typographic styles

Style	Function
Emphasis	Programs or important things
Features and registers	Names for GenICam features or for camera control registers
<i>Feature and register options</i>	Options for GenICam features or for camera control registers
<i>Input commands</i>	Text or command to type in by the user, selectable options
UIElements	Text displayed or output by the system: GUI, dialog boxes, buttons, menus, important information, or windows titles
Web addresses and references	Links to webpages and internal cross references

Table 3: Typographic styles

Symbols and notes



CAUTION

Risk of burns

Precautions are described



CAUTION

Injury by falling cameras or lenses

Precautions are described



CAUTION

Risk of cuts by sharp edges

Precautions are described



NOTICE

Material damage

Precautions are described.



Practical tip

Additional information helps to understand or ease handling the camera.



Avoiding malfunctions

Precautions are described.



Additional information

Web address or reference to an external source with more information is shown.

GenICam for CSI-2 Access

Selected Alvium 1800 C models support **GenICam for CSI-2 Access**, see [Access modes](#) on page 226. Data in this document applies to all Alvium CSI-2 cameras if not otherwise stated. Data applying to **GenICam for CSI-2 Access** is marked as follows:



Paragraphs and graphics

A gray box with this icon signals that contents apply to **GenICam for CSI-2 Access** only.



Specification headlines

This icon signals that camera models support **GenICam for CSI-2 Access** (in addition to the other access modes).

Tables

Red table border lines signal that data applies to **GenICam for CSI-2 Access** only:

Feature	Specification
Feature 1	This specification applies to all access modes .
Feature 2	This specification applies to GenICam for CSI-2 Access only.

Naming and terms

Controls and features

Most functionalities for Alvium CSI-2 cameras are available as controls, using **Direct Register Access** or **Video4Linux Access**. Equivalent functionalities are available as features, using **GenICam for CSI-2 Access**, adding some more functionalities. **Gain Auto** in the Alvium CSI-2 Register Controls Reference equals **GainAuto** in the Alvium Features Reference.

In this user guide, data relating to features applies to the corresponding controls as well, unless otherwise stated. Therefore, the terms **Control** and **Feature** are used equivalently in this user guide.

ROI and cropping

Cropping is a functionality similar to ROI (region of interest). By using a reduced area of the available sensor, the payload is reduced, increasing frame rates.

With **GenICam for CSI-2 Access**, features, such as **Width**, **Height**, **OffsetX**, and **OffsetY** are used, according to the GenICam SFNC (Standard Features Naming Convention).

With the **other Access modes**, the corresponding controls are used.



Descriptions of controls and features

For the Alvium CSI-2 Register Controls Reference and the Alvium Features Reference, see www.alliedvision.com/en/support/technical-documentation/alvium-csi-2-documentation.

Camera model naming

Alvium cameras are named to identify model properties.

For example, **Alvium 1500 C-500c** is composed of:

	Alvium	1500	C	500	c
Content element	Camera series	Camera series detail	Interface	Resolution ¹	Color/monochrome
Examples	Alvium	1500: Basic feature set 1800: Advanced feature set or high-performance sensors	C: MIPI CSI-2 U: USB	500: 5.0 MP 050: 0.5 MP	c: color m: monochrome

¹Model resolutions may slightly deviate from model naming.

Table 4: Camera model naming

Terms and acronyms

Term or acronym	Description	Reference
adapter board	Printed circuit board (PCB) that connects embedded boards, cameras, and I/Os, dedicated to an individual embedded board	www.alliedvision.com/en/products/accessories
bare board	Camera consisting of electronics and sensor on a common printed circuit board (PCB), to be designed into a housing with heat sink and lens mount	Bare Board (standard Alvium) on page 190
CRA	Chief ray angle	Alvium 1500 C-050m/c on page 71
EMVA	European Machine Vision Association	www.emva.org

Table 5: Terms and acronyms (sheet 1 of 2)

Term or acronym	Description	Reference
ERS	Electronic rolling shutter, see RS	Shutter types affecting image readout on page 276
ESD	Electrostatic discharge	ESD on page 54
FPC cable	(MIPI CSI-2 FPC cable) Flexible printed circuit cable, component that connects embedded boards and cameras via adapter board	www.alliedvision.com/en/products/accessories
FPC connector	Hirose FH55-22S-0.5SH connector	www.hirose.com
FPNC	Fixed pattern noise correction	Image data flow on page 267
fps	Frames per second	Alvium 1500 C-050m/c on page 71
GND	Ground (power)	Hirose FH55 connector pin assignment on page 248
Gbit/s	Gigabit per second	Alvium 1500 C-050m/c on page 71
GRRS	Global reset release shutter, see GRS	Shutter types affecting image readout on page 276
GRS	Global reset shutter, see GRRS	Shutter types affecting image readout on page 276
GS	Global shutter	Shutter types affecting image readout on page 276
H × V	Horizontal × Vertical (sensor resolution)	Alvium 1500 C-050m/c on page 71
KByte	Kilobyte	Alvium 1500 C-050m/c on page 71
MP	Megapixels (see P)	Alvium 1800 C model specifications on page 91
P	Pixels (see MP)	Alvium 1800 C model specifications on page 91
PCB	Printed circuit board	Connecting FPC cable and FPC connectors on page 234
PCBA	Printed circuit board assembly	PCBAs on page 54
open housing	Camera housing that is open at the back side to be designed into an encompassing housing with other components	Open Housing C-Mount (standard Alvium) on page 192
QE	Quantum efficiency	Absolute QE on page 73
ROI	Region of interest	V4L2 controls and register controls on page 229
RS	Rolling shutter, see ERS	Shutter types affecting image readout on page 276
SFNC	Standard Features Naming Convention (GenICam)	www.emva.org
S-Mount	M12-Mount	Mounting and focusing S-Mount lenses on page 243

Table 5: Terms and acronyms (sheet 2 of 2)

Compliance, safety, and intended use



This chapter includes:

Camera identification.....	49
Compliance notifications	49
Intended use	50
Copyright and trademarks	51
Your safety.....	51
Product safety	53

Camera identification

You can identify your Alvium CSI-2 camera like this:

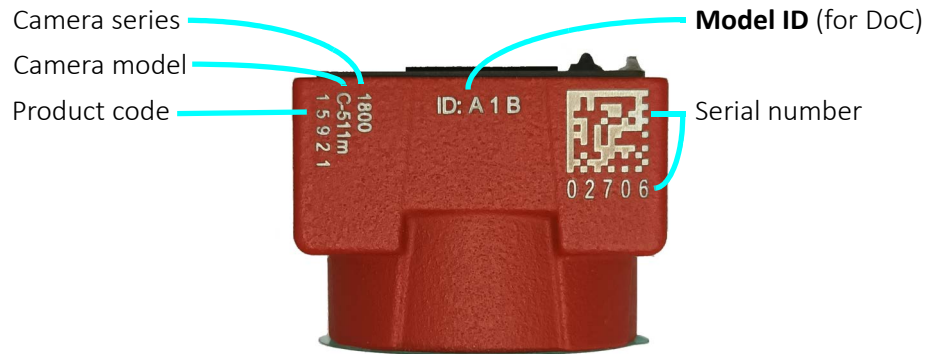

Figure 5: Hardware options and model IDs

Hardware option	Model ID
Open housing standard Alvium CSI-2 cameras	A1B
Open housing Alvium CSI-2 Flex cameras	A1R
Alvium CSI-2 Frame cameras	A1B
Alvium CSI-2 Frame Flex cameras	A1R

Table 6: Hardware options and model IDs

Preparations to introduce Model IDs for Alvium **bare board cameras** are ongoing. Corresponding data will be added to a future version of this document.

Compliance notifications



National regulations on disposal must be followed.

Bare board and open housing cameras

Bare board and open housing cameras are designed for integration and are delivered without closed housing on customer's request. Housing design is critical for electromagnetic compatibility (EMC) of the camera.



Requirements for EMC housings

See the Electromagnetic Compatibility for Open Housing Alvium Cameras application note at

www.alliedvision.com/en/support/technical-documentation/alvium-csi-2-documentation.

Avoid electromagnetic interferences

Interface cables, power cables, and I/O cables are sensitive to electromagnetic interference.

- Use shielded cables only.
- We recommend using cables offered by Allied Vision.
- Avoid coiling.
- We recommend using GPIOs only in environments with low electromagnetic interference.

Moreover, avoid unnecessary bending to prevent damaging the cables.

Intended use

Allied Vision's objective is the development, design, production, maintenance, servicing and distribution of digital cameras and components for image processing. We are offering standard products as well as customized solutions.

Intended use of Allied Vision product is the integration into Vision systems by professionals. All Allied Vision product is sold in a B2B setting.

Allied Vision isn't a legal manufacturer of medical product. Instead, Allied Vision cameras and accessories may be used as components for medical product after design-in by the medical device manufacturer and based on a quality assurance agreement (QAA) between Allied Vision (supplier) and medical device manufacturer (customer). Allied Vision's duties in that respect are defined by ISO 13485, clause 7.2 (customer-related processes, equivalent to ISO 9001, clause 8.2).

Copyright and trademarks

All text, pictures, and graphics are protected by copyright and other laws protecting intellectual property. All content is subject to change without notice.

All trademarks, logos, and brands cited in this document are property and/or copyright material of their respective owners. Use of these trademarks, logos, and brands does not imply endorsement.

Copyright © 2023 Allied Vision Technologies GmbH. All rights reserved.

Your safety

This section informs about issues related to your personal safety. Descriptions explain how to avoid hazards and operate Alvium CSI-2 cameras safely.

Handling lens mounts and Alvium Frame

The lens mount thread can have sharp edges. Be careful these edges do not cut your skin when mounting or unmounting lenses.

The circular front opening of Alvium Frame cameras has sharp edges.

- Avoid touching these edges with your fingers.
- Wear protective gloves for handling Alvium Frame cameras with an open circular front opening.

Follow the instructions in [Installing Alvium Frame](#) on page 239.

Housed cameras: handling hot cameras

If the mainboard temperature exceeds the specified maximum for more than two seconds, the camera is powered off automatically. The current value for mainboard temperature is output by `DeviceTemperature`, using Direct Register Access. You can use this value to control cooling by software, for example, to control a fan.

However, if you hold the camera in your hands during operation, your skin may get hurt. If you touch the camera when it is heated up, we recommend wearing protective gloves.

Providing optimum heat dissipation

Design bare board and open housing cameras into a heat dissipative housing with a high thermal conductivity. For more information, see [Mounting bare board cameras](#) on page 237. Keep the operating temperature in the specified range to enable best image quality and to protect the camera from damage. Temperature values apply to a relative humidity of 0 to 80 percent that is non-condensing.

Hardware option	Housing	Components in the cooling area ¹	Mainboard ²
Bare board ³	Not applicable		See model
Open housing ⁴	-20 °C to +65 °C	-20 °C to +85 °C	Specifications on page 60.

¹See [Mounting the heat sink](#) on page 236.

²Output by `DeviceTemperature`, using Direct Register Access.

³Ensure that the sensor is operated in the temperature range specified by the manufacturer. For any questions, please visit www.alliedvision.com/en/support.

⁴Temperature values must be observed for the housing **and** for the cooling area.

Table 7: Operating temperature ranges for Alvium CSI-2 cameras

For your safety and to improve camera performance, operate the camera:

- Mounted to a base with a high thermal conductivity
- With lens or other optical components mounted
- With a heat sink mounted that has large surface areas (closed housing cameras include a heat sink)
- Using conductive media for camera and heat sink mounting
- With active cooling of camera, mounting base, and heat sink, such as by ventilation.
- Reduce high ambient temperature. For example, in outdoor applications with direct sunlight, provide shading by an enclosure.

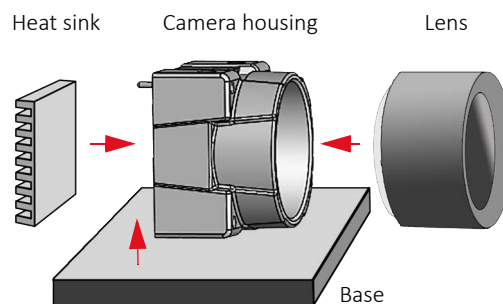

Figure 6: Setup to provide optimum heat dissipation



More information

For more information on heat dissipation, see the [Optimum Heat Dissipation for Alvium Cameras](#) application note at www.alliedvision.com/en/support/technical-documentation/alvium-csi-2-documentation.

Camera mounting

Housed cameras must be mounted using the mounting threads. If vibration is higher than specified, cameras can disconnect from the mounting base. Falling cameras can hurt you. To avoid personal injury:

- Mount the camera according to the instructions in [Mounting open housing cameras](#) on page 238.
- Ensure, shock and vibration do not exceed the specified range, see [Shock and vibration](#) on page 61.
- Use a lens support if you want to use [Heavy lenses](#).

Heavy lenses

- For non-static applications, use lenses with a mass less than 70 grams and a length less than 38 mm, where the center of gravity is 20 mm, measured from the lens mount front flange. For heavier or longer lenses, use a lens support and apply additional tests. For more information, please contact support at www.alliedvision.com/en/about-us/contact-us/technical-support-repair/-/rma.

Product safety

To prevent material damage, read the following and understand how to safely handle and operate the camera.

Embedded systems

Setup and operation of Alvium CSI-2 cameras in embedded systems is different than for cameras in PC-based systems. Components can easily be damaged.

If you are unfamiliar with embedded systems, be extremely careful. Follow the instructions in [Installing the hardware](#) on page 231.

Supported embedded boards

We have tested that Alvium CSI-2 cameras can be operated properly with the referenced embedded boards. For information on using these components safely, please see the documentation provided by the manufacturers of the embedded boards.

Electrical connections

The MIPI CSI-2 standard does not specify electrical connections as extensively as the USB or GigE standard. Read specifications carefully.

Allied Vision accessories help to avoid damage to the camera and connected components. See www.alliedvision.com/en/products/accessories for suitable accessories. See [Specifications](#) on page 60 and [Installing the hardware](#) on page 231.

Alvium CSI-2 cameras are not protected against damage caused by reverse polarity.

- For specifications, see [Hirose FH55 connector pin assignment](#) on page 248.
- For instructions to avoid electronics damage, see [Connecting FPC cable and FPC connectors](#) on page 234.

ESD

Follow these instructions to avoid damage to the camera, including possible **damage to the sensor**, see [Possible damage to image sensors due to electrostatic charge](#) on page 58.

ESD is dangerous for electronic devices, especially when tools or hands get in contact with connectors and electronic components. We recommend measures to avoid damage by ESD:

- Unpacking: Remove the camera from its anti-static packaging only when your body is grounded.
- Workplace: Use a static-safe workplace with static-dissipative mat and air ionization.
- Wrist strap: Wear a static-dissipative wrist strap to ground your body.
- Clothing: Wear ESD clothing. Keep components away from your body and clothing. Even if you are wearing a wrist strap, your body is grounded but your clothes are not.
- Housing: use an ESD housing, including the camera, embedded board, adapter board, and MIPI CSI-2 FPC cable.

Cable connections

Provide sufficient strain relief for all cable connections to avoid short circuits and malfunctions.

PCBAs

Alvium CSI-2 cameras enable access to PCBAs. Keep away from camera electronics to avoid damage.

Camera power

Operating cameras beyond the specified range damages cameras. Cameras are powered using the Hirose FH55 connector for standard Alvium CSI-2 cameras and the Hirose DF40C-50DP-0.4V connector for Alvium CSI-2 Flex cameras at a maximum input of 5.5 VDC with minimum 1.5 A, using a limited power source (LPS), according to IEC 62368-1. The camera is not intended to be connected to a DC distribution network.

Only use power supplies that meet the insulation requirement according to PELV or SELV. For details, please refer to IEC 61140.

Ground loops

Unsuitable connections can lead to different potentials between the camera system GND and the environmental shield/chassis GND caused by ground loops. This can damage the camera and the connected devices or cause malfunctions.

- Avoid potential differences between the camera housing and GND.
- All wiring must be done by authorized personnel, according to the corresponding technical standards.
- You may mount the camera electrically isolated.
- Read the Avoiding Ground Loops in Vision Systems application note.



More information

See the Avoiding Ground Loops in Vision Systems application note at www.alliedvision.com/en/support/technical-documentation/alvium-csi-2-documentation.

Hirose FH55 and DF40C-50DP-0.4V connectors

Hirose FH55-22S-0.5SH FPC connectors and Hirose DF40C-50DP-0.4V board-to-board connectors enable compact camera design.

The small-sized connectors are sensitive to mechanical stress and are specified for maximum 20 mating and unmating cycles. Especially if you are inexperienced with these connectors, be very cautious. If these connectors are broken, cameras must be replaced. To install and operate cameras safely, read this section carefully.



Additional information

For technical data and more instructions on the Hirose connectors, see the manufacturer data sheet at www.hirose.com.

Hirose FH 55 FPC connectors

Instructions in [Installing the hardware](#) on page 231 include helpful information to enable proper installation.

- Avoid stress to FPC connectors.
- Allow only the FPC cable to touch conductors.

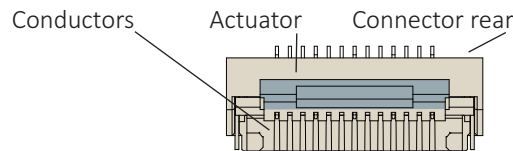

Figure 7: Hirose FH55-22S-0.5SH FPC connector

Handling the actuator

- Move the actuator only between 0 degrees (locked position) and 105 degrees (open position).
- Carefully flip the actuator at the middle with your finger nail, see [Connecting FPC cable and FPC connectors](#) on page 234.

MIPI CSI-2 FPC cables



Manufacturing FPC cables or embedded boards

If you want to design your own components to connect Alvium CSI-2 cameras to embedded boards, contact your Allied Vision Sales representative or visit www.alliedvision.com/en/about-us/contact-us/technical-support-repair/-/rma.

FPC cable position

Short circuits of the FPC cable can damage the camera or connected hardware.

- Insert the FPC cable into the connector with cable guiding tabs matching the connector's side guides. See [Connecting FPC cable and FPC connectors](#) on page 234.
- Connect the camera and the embedded board (adapter) only as shown by the arrow printed on the FPC cable, see [Connecting FPC cable and FPC connectors](#) on page 234.

FPC cables and stress

Over-stressed FPC cables can damage the camera and connected hardware. When camera and embedded board are twisted against each other or pulled apart from each other with too much force, the FPC cable is over-stressed. Spring contacts of FPC connectors are worn out, causing short circuits and unreliable electrical connections.

- Insert the FPC cable into the FPC connector at 12 degrees to the PCB board surface. See [Connecting FPC cable and FPC connectors](#) on page 234.
- Allow only slight bending of the FPC cable (minimum bending radius: 10 mm).
- Provide strain relief to avoid short cuts and malfunctions.

No hot-plugging for MIPI CSI-2

Alvium CSI-2 cameras do not support hot-plugging. Hot-plugging can destroy the camera and connected hardware by high inrush current.

Disconnect power supplies before connecting FPC cables.

FPC cable signal quality

Noise and electromagnetic interference can disable camera functions.

- Avoid contact to metal surfaces, causing electromagnetic interference.
- Please use cables recommended by Allied Vision.

Handling bare board cameras

Bare board cameras are an electronic assembly without a protective housing. Therefore, they can easily be damaged.

- Handle bare board cameras with extreme care.
- Avoid any mechanical stress to the sensor area.
- Avoid short circuits by keeping away from electronics components.

Observe for mounting bare board cameras:

- Allow mechanical contact only at the mounting area. (This does not apply to the cooling area.)
- Enable proper cooling at the cooling area, see [Mounting bare board cameras](#) on page 237.
- Give 2 mm minimum clearance above board components.
- Tighten screws at 0.1 Nm maximum torque.
- Follow the instructions in [Mounting bare board cameras](#) on page 237.

Optical components

Provide the following conditions to keep dirt and droplets out of the optical system of camera and lens:

- Dust-free environment
- Low relative humidity
- No condensation.

When camera or lens are stored:

- Cover the lens mount with a protection foil or cap.
- Cover front and back lens with caps.



Damage to optical components by conductive media for heat sinks

See [Conductive media for heat sinks](#) on page 59 for details.

Sensor

Sensors are sensitive to excessive radiation: focused sunlight, UV light, lasers, and X-rays can damage the sensor. Dirt and scratches can damage the sensor as well.

Alvium CSI-2 cameras do not need additional cleaning. Cameras are cleaned before shipping. Incorrect cleaning can damage the sensor or the filter. Therefore, never clean the sensor or the filter.

Protect the camera filter and the sensor from dirt, because dirt becomes more visible the closer it gets to the sensor. In addition, keep the back lens clean. Hold the camera with the lens mount facing the ground to keep dirt out of the lens mount. When no lens is mounted, protect the sensor and filter by a dust cap.

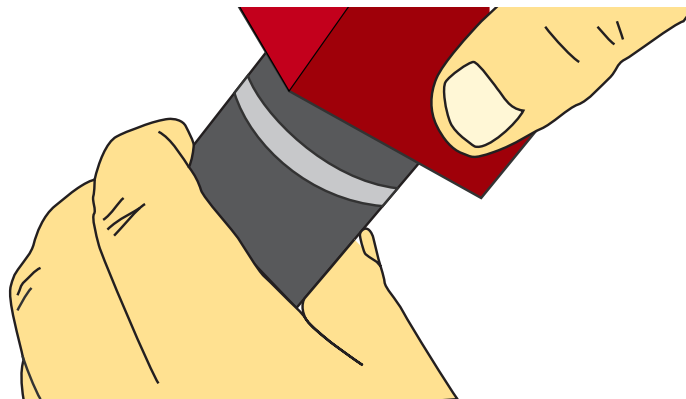

Figure 8: Holding the camera with the lens mount facing the ground

Possible damage to image sensors due to electrostatic charge

Generally, bare board cameras and cameras with incomplete housings are very sensitive to electrostatic discharge (ESD) as electronics components are not protected.

In some rare cases, electrostatic charge occurring on the surface of the image sensor may cause damages to particular pixel groups, which may become visible as bubbles or blobs in the image generated by the sensor.

Therefore, it is very important to comply with ESD protection measures in accordance with technical standards.

Follow the instructions in [ESD](#) on page 54.

Lenses

Maximum protrusion

The sensor, filter, lens, or camera electronics can be damaged if an object (typically a lens) exceeding maximum protrusion is mounted to the camera. Use lenses with a maximum protrusion within camera specifications. [Figure 9](#) shows maximum protrusion. For details, see [Maximum protrusion for front mounts](#) on page 202.

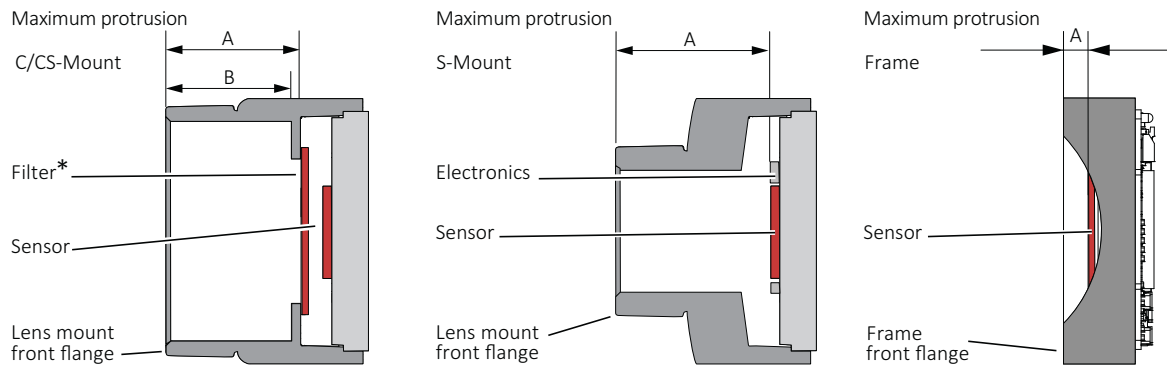

*Only color models are equipped with an IR cut filter

Figure 9: Maximum protrusion CS-Mount and C-Mount, S-Mount, Frame

For S-Mount lenses, read [Mounting and focusing S-Mount lenses](#) on page 243 to avoid damage to the sensor, electronics, and lens.

Mechanical components

Heat sinks

Heat sinks can be used to cool the camera for safety and to improve image quality. Adhere to the instructions provided by the manufacturer of the heat sink.

Conductive media for heat sinks

Some conductive media for heat sinks contain corrosive substances that can damage optical surfaces of the sensor, filter, and lens.

- Cover the optical path of the camera when you apply heat sink compound or adhesive to prevent substances and fumes from damaging optical surfaces.
- Adhere to the instructions and safety notes provided by the manufacturer of the conductive media.
- Ensure that the conductive media is correctly positioned: covering only the **cooling area**, see [Mounting the heat sink](#) on page 236.

Specifications



This chapter includes:

Applied standards	61
Notes on specifications	64
Alvium 1500 C model specifications	71
Alvium 1800 C model specifications	91
White balance default	188
Standard Alvium: Dimensions and mass	189
Standard Alvium: Technical drawings	190
Alvium Flex: Dimensions and mass	189
Alvium Flex: Technical drawings	195
Alvium Frame: Dimensions and mass	200
Alvium Frame: Technical drawings	200
Alvium Frame Flex: Dimensions and mass	201
Alvium Frame Flex: Technical drawings	201
Maximum protrusion for front mounts	202
IR cut filter	203
Sensor position accuracy	204
User sets	207
Camera feature availability	208

Applied standards



GenICam

GenICam provides a generic access for cameras and devices that is independent of the interface. This enables operating cameras with USB3 Vision, GigE Vision, or CoaXPress interfaces with a common software. With the CSI-2 transport layer for Alvium, MIPI CSI-2 is added.

GenICam consists of multiple modules for different tasks. Allied Vision cameras and software use these modules, like the SFNC that standardizes feature names and types via an XML file or the transport layer interface (GenTL) used to grab images.

Selected Alvium 1800 C cameras comply to:

- GenICam Standard Document Version 2.1.1
- GenAPI Schema Version 1.1
- GenAPI Version 3.1
- GenICam Standard Features Naming Convention (SFNC) Version 2.7
- GenICam Pixel Format Naming Convention (PFNC) Version 2.2

MIPI CSI-2

The MIPI (Mobile Industry Processor Interface) CSI (Camera Serial Interface)-2 standard describes a class of MIPI CSI-2 cameras for still image photography and video streaming. Generically, MIPI CSI-2 cameras are operated by Direct Register Access. Alvium CSI-2 cameras have a MIPI CSI-2 interface. They comply with:

- MIPI CSI-2 V1.1
- D-PHY V1.1.

V4L2

The current V4L2 framework is described at linuxtv.org. Allied Vision provides V4L2 drivers. You can download Allied Vision V4L2 drivers from www.alliedvision.com/en/products/software/embedded-software-and-drivers.

Shock and vibration

Alvium closed and open housing cameras were tested according to the following standards:

- IEC 60068-2-6, sinusoidal vibration testing
- IEC 60068-2-27, shock testing
- IEC 60068-2-64, random vibration testing.

Cameras were inspected before and after the tests. All tests were passed successfully:

Condition	Passed
Mechanics	<ul style="list-style-type: none"> The camera housings showed no deformations. The connections between camera components had not come loose. The sensor position was within the specified tolerances of a new camera.
Camera behavior	Camera functionalities were not affected, no deviations occurred.
Image streaming	Images were streamed without errors.

Table 8: Conditions for passed tests

The conditions for cameras and lenses were the same for all tests. Solid aluminum tubes were used to represent real lenses:

Parameter	Value
Lens dummy length	38 mm
Lens dummy mass	70 g
Center of gravity (CoG) ¹	20 mm

¹For camera and lens dummy assemblies, measured from the lens mount front flange

Table 9: Conditions for lenses

IEC 60068-2-6: Sinusoidal vibration

Frequency	Acceleration	Displacement
10 Hz to 58.1 Hz	Not applicable	1.5 mm
58.1 Hz to 500 Hz	20 g	Not applicable

Table 10: Frequency, acceleration, and displacement for IEC 60068-2-6 tests

Parameter	Value
Axis	x, y, z
Sweep rate	1 oct/min
Sweep duration per axis [hh:mm:ss]	00:11:17
Number of sweeps	20

Table 11: Other parameters for IEC 60068-2-6 tests

IEC 60068-2-27: Shock

Parameter	Value
Axis	x, y, z
Acceleration	20 g
Number of shocks per axis	10
Duration per axis	11 ms
Waveform	Half sine

Table 12: Parameters for IEC 60068-2-27 tests

IEC 60068-2-64: Random vibration

Frequency	Acceleration
15 Hz to 500 Hz	0.05 g ² /Hz

Table 13: Frequency and acceleration for IEC 60068-2-64 tests

Parameter	Value
Axis	x, y, z
Acceleration RMS (Sigma)	4.9 g
Acceleration peak (Sigma)	14.8 g
Duration per axis [hh:mm:ss]	00:30:00

Table 14: Other parameters for IEC 60068-2-64 tests

Notes on specifications

This section defines the conditions for specifications stated in this chapter.

Sensor

Absolute QE plots

Measurements for color cameras were done with IR cut filter, measurements for monochrome and S-Mount cameras were done without optical filters. With optical filters, QE decreases by approximately 10 percent. The uncertainty in measurement of the QE values is ± 10 percent. This is mainly due to uncertainties in the measuring apparatus itself (such as Ulbricht sphere and optometer).

Manufacturing tolerance of the sensor increases overall uncertainty.

Sony sensors

Sony provides relative response curves in their sensor data sheets. To create the absolute QE plots shown in this chapter, the relative response was converted to a normalized QE response and then adjusted as per three measured QE values (at 448 nm, 529 nm, 632 nm) for color sensors and one measured QE value (at 529 nm) for monochrome sensors.

ON Semiconductor sensors

The curve in the absolute QE plots shown in this chapter is from the sensor manufacturer data sheet. The information was correct at the time of publishing.

Wavelength

The wavelength range in the absolute QE plots reflects the information available in the sensor manufacturer data sheet at the time of publishing. For additional wavelength information, contact the sensor manufacturer.

Spectral response plots

The curves in the spectral response plots shown in this chapter were calculated from measured quantum efficiencies at 448 nm, 529 nm, and 632 nm. The shape of the curve is taken from the sensor data sheet but the values have been adjusted based on these measured values. The uncertainty in measurement of the spectral response values is ± 10 percent.

Pixel format default and naming



GenICam for CSI-2 Access

The **default pixel format** for Alvium CSI-2 cameras is RGB8 for color models and Mono8 for monochrome models.

Pixel formats are named according to the PFNC (Pixel Format Naming Convention), see [GenICam](#) on page 61.

Other access modes

The **default pixel format** for Alvium CSI-2 cameras is RGB888 (RGB3). Monochrome cameras are included to enable quick access on V4L2 where V4L2_PIX_FMT_UYVY is the default. For monochrome cameras, the 3 bytes for RGB are set to a common value, resulting in gray.

Pixel formats are named as extended MIPI CSI-2 definitions.

- [Video4Linux Access](#): According to V4L2 definitions.
- [Direct Register Access](#): Alvium CSI-2 cameras output pixel formats according to the MIPI CSI-2 standard.

Naming pattern	Examples
MIPI CSI-2 (FOURCC)	RAW8 (GREY) RGB888 (RGB3)

Table 15: Extended MIPI CSI-2 definitions for pixel format naming

Pixel formats for various standards

MIPI CSI-2	V4L2	V4L2 FOURCC	PFNC
YUV422 8-bit	V4L2_PIX_FMT_UYVY	UYVY	YCbCr422_8_CbYCrY
RGB888	V4L2_PIX_FMT_RGB24	RGB3	RGB8
RAW8	V4L2_PIX_FMT_GREY	GREY	Mono8
RAW10	V4L2_PIX_FMT_Y10	Y10	Mono10
RAW12	V4L2_PIX_FMT_Y12	Y12	Mono12

Table 16: Equivalent pixel formats in various standards



Availability of pixel formats

The availability of pixel formats depends on camera models and the abilities of the connected system.

Exposure time and frame rates

Achieved values deviating from specified values

Values stated in the model specifications show the maximum available on an ideal system, supporting a bandwidth of 1.051 Gbit/s per lane. Your individual setup may affect available values such as for:

- Minimum and maximum exposure times and increments
- Maximum frame rates, including ROI frame rates
- Image resolution steps.
- **Image resolution steps.** Depending on the available increments, some standard resolutions are not supported. For example, instead of 1,440 × 900 pixels for WXGA+, 1,440 × 904 pixels are available.
- **Minimum resolution.** Depending on the embedded board, minimum resolution may be greater than stated in tables. For example, instead of 16 × 16 pixels, the minimum resolution available may be 256 × 32 pixels.
- We recommend you to set ROI values before you set values for Exposure Time, because interdependencies between controls affect each other. See [Value changes by control interdependencies](#) on page 272.
- **Deviations from stated frame rates** can occur, especially when:
 - The camera is operated in triggered mode
 - Low bandwidth is used
 - Small ROIs are used.

CSI-2LaneCount and CSI-2ClockFrequency

Alvium cameras require higher bandwidths than supported by only one CSI-2 lane, especially with low CSI-2 clock frequencies. We recommend you to do extensive testing to find the best setup for maximum frame rates, regarding:

- CSI-2LaneCount
- CSI-2 ClockFrequency (CSI-2 Clock).

Dropped frames or a viewer issue?

Alvium CSI-2 cameras are designed for a maximum bandwidth that does not exceed board abilities. However, if your setup does not provide sufficient bandwidth, frames are dropped. Even if bandwidth is sufficient, embedded boards may not be able to display all images of an image stream. In this case, only the display is affected but no dropped frames occur.

Frame rates with ROI/Cropping

ROI and Cropping work similarly: While ROI is typically used for **GenICam for CSI-2 Access**, Cropping is typically used for the **other access modes**. By using a reduced area of the available sensor, the payload is reduced, increasing frame rates. This user guide uses the term ROI.

The maximum frame rate which can be achieved depends on various values, such as bandwidth, pixel format, exposure time, and ROI. Calculation of maximum frame rates for different ROIs for Alvium CSI-2 cameras does not allow to give a formula. Data is calculated for [Operation for maximum frame rates](#) on page 68.



Readout modes to reduce the bandwidth

Selected Alvium CSI-2 camera models support various readout modes. This is stated in the tables for ROI frame rates.

If you are using pixel formats that do not require 12-bit sensor readout and you want to achieve higher frame rates, you can select between readout modes for 12-bit, 10-bit, and 8-bit with some Alvium CSI-2 camera models. See your model's specifications.

By default, Alvium 1800 CSI-2 models use the maximum (ADC) bit depth for **SensorBitDepth**. For selected models, *Adaptive* mode switches automatically between 12-bit and 10-bit sensor readout, depending on the bit depth of the selected pixel format. This allows to reduce bandwidth and increase frame rates when only 10-bit is required.

To enable the 8-bit sensor readout mode, you must switch manually, using **SensorBitDepth**. Please observe that the image brightness changes when you switch between 8-bit sensor readout mode and the other sensor readout modes.



Maximum frame rates at different values for **SensorBitDepth**

When the maximum bandwidth supported by CSI-2 interface is reached, reducing the value for **SensorBitDepth** does not increase the available maximum frame rate.

Exposure time behavior regarding ExposureMode

This section informs about how exposure time behaves in the different exposure modes.

All Alvium cameras have an exposure time offset. The exposure time offset and the exposure time increment depend on sensor and camera characteristics. Both, the exposure time offset and the exposure time increment, can change if **Width**, **PixelFormat**, or values for **CSI-2LaneCount**, or **CSI-2 ClockFrequency** are changed. See [Value changes by control interdependencies](#) on page 272.

ExposureMode = Timed

For all Alvium CSI-2 cameras, exposure time can be set by **ExposureTime** or **ExposureAuto**. For this, **ExposureMode** is set to *Timed*.

The selected exposure time is extended automatically:

- If the selected exposure time does not match the available increment, the camera automatically extends the exposure time to the next increment.
- The **exposure time offset is included** in the selected exposure time.



ExposureMode = TriggerWidth or TriggerControlled

In addition, most global shutter (GS) cameras can control exposure time by the trigger signal, with the `ExposureMode` set to `TriggerWidth` or `TriggerControlled` (using `ExposureStart` and `ExposureStop`).

The trigger controlled exposure time is extended automatically:

- If the trigger controlled exposure time does not match the available increment, the camera automatically extends the exposure time to the next increment.
- Subsequently, the **exposure time offset is added**.

You can use `ExposureActive` to determine the duration of the exposure time offset.

Operation for maximum frame rates

Values for maximum frame rates and for minimum and maximum exposure time in the specification tables are based on following parameters:

- Factory settings (camera after power up)
- Minimum exposure time
- Full resolution
- Pixel format
 - **GenICam for CSI-2 Access:** Mono8 or Bayer8 pixel format
 - **Other access modes:** RAW8 (GREY) for monochrome and color models
- Camera operation in freerun mode
- Without bandwidth limitations.

Frame rates with rolling shutter sensors

The following table shows how the shutter type impacts available frame rates. Reducing the area for ROI reduces readout time. The relations in [Table 17](#) apply only if exposure time is shorter than readout time.

Sensor type	Shutter mode	Trigger mode	Frame rates at full resolution ¹	ROI frame rates
All models, except for...	Global shutter (GS)	Freerun	100%	Increased values
	Global shutter (GS)	External trigger	100%	
1800 C-500	Rolling shutter (RS)	Freerun	100%	Increased values
	Rolling shutter (RS)	External trigger	>50%	
1800 C-1240	Rolling shutter (RS)	Freerun	100%	No increase
	Rolling shutter (RS)	External trigger	>99%	
	Global reset shutter (GRS)	Freerun	>99%	
	Global reset shutter (GRS)	External trigger	>99%	
1800 C-2050	Rolling shutter (RS)	Freerun	100%	Increased values
	Rolling shutter (RS)	External trigger	>99%	
	Global reset shutter (GRS)	Freerun	>99%	
	Global reset shutter (GRS)	External trigger	>99%	
¹ Related to the values for maximum frame rates stated in the specification tables for each model. Available with GenICam for CSI-2 Access only				

Table 17: Frame rates depending on shutter types and trigger modes



Delays

- For delays, see [Trigger latency](#) on page 259.
- Achieved frame rates may not match specified values:
 - Some sensors have an exposure start jitter that may reduce maximum frame rates.
 - Your individual setup may cause delays in data transmission.

Sensor shutter types

Differences between global shutter (GS), rolling shutter (RS), and global reset shutter (GRS, **GenICam for CSI-2 Access** only) sensors are explained in [Shutter types affecting image readout](#) on page 276. Triggering behavior differs between cameras with global shutter (GS) and rolling shutter (RS). See [Triggering](#) on page 257 for details.

Digital binning

Selected Alvium 1800 C cameras combine digital horizontal binning and digital vertical binning for integer values 1 to 8. In GenICam for CSI-2 Access, horizontal and vertical binning values can be combined freely. In other access modes, horizontal and vertical values can be combined commonly only.



Alvium 1800 C models ≥ 12 MP resolution

If digital horizontal and digital vertical binning are set to 1 \times and the digital vertical binning value is increased, digital horizontal binning is automatically set to 2 \times .



Sensor binning

Selected camera models support sensor binning in addition to digital binning. From these models, all support *Sum* for binning, some also support *Average*. See the specifications tables in [Alvium 1800 C model specifications](#) on page 91.



Please observe

- Only digital binning or sensor binning can be used at a time.
- You must revert binning values to **1** before you can switch between these binning modes.

Operation for medium power consumption

Values for power consumption in the specification tables are based on following parameters:

- Factory settings (camera after power up)
- Minimum exposure time
- Maximum frame rate
- Full resolution
- Pixel format (monochrome and color models)
 - **GenICam for CSI-2 Access:** Mono8 or Bayer8
 - **Other access modes:** RAW8 (GREY)
- Camera operation in freerun mode
- Without bandwidth limitations.

Dimensions and mass

For your model's dimensions, see [Standard Alvium: Dimensions and mass](#) on page 189. In manufacturing, camera board and sensor are moved against each other to adjust flange focal distance. The value range for camera length with open housing cameras reflects in the technical drawings. See [Standard Alvium: Technical drawings](#) on page 190.

Alvium 1500 C model specifications

Alvium 1500 C-050m/c



Supported firmware version

Alvium 1800 C-050 models are delivered with firmware 00.11.00.9cf0c21e. The firmware version cannot be updated to later versions.

Feature	Specification	
	1500 C-050m (monochrome)	1500 C-050c (color)
Sensor model	ON Semiconductor PYTHON 480	
Resolution	808 (H) × 608 (V); 0.5 MP	
Sensor type	CMOS	
Shutter type	Global shutter (GS)	
Sensor size	Type 1/3.6; 3.9 mm × 2.9 mm; 4.9 mm diagonal	
Pixel size	4.8 μm × 4.8 μm	
CRA	1.65 deg	
ADC bit depth	10-bit	
YUV color pixel formats	Not applicable	YUV422 8-bit (UYVY)
RGB color pixel formats	Default: RGB888 (RGB3)	
RAW pixel formats	RAW8 (GREY), RAW10 (Y10)	
Maximum frame rate	117 fps, using 1 to 4 lanes	
Exposure time	64 μs to 10 s (1 lane)	
Gain	0 dB to 11.3 dB; 0.1 dB increments	
Digital binning	Horizontal: 1 to 8 columns; Vertical: 1 to 8 rows	
Image buffer (RAM)	256 KByte	
Non-volatile memory (Flash)	1024 KByte	
GPIOs	2 programmable GPIOs As direct inputs (push-pull): 0 to 5.5 VDC As direct outputs (push-pull): 0 to 3.3 VDC at 12 mA	
Power requirements	Power over MIPI CSI-2	
Power consumption (typical, at 5 VDC)	1.3 W	
Storage temperature	-20 °C to +85 °C ambient temperature	

Table 18: Alvium 1500 C-050m/c specifications (sheet 1 of 2)

Feature	Specification			
	1500 C-050m/c			
Operating temperature	Hardware option	Housing	Cooling area ¹	Mainboard ²
	Bare board ³	Not applicable	-20 °C to +85 °C	-20 °C to +85 °C
	Open housing ⁴	-20 °C to +65 °C		
Relative humidity	0% to 80% (non-condensing)			
Digital interface	MIPI CSI-2 D-PHY V1.1; 1, 2, or 4 lanes; maximum 1.051 Gbit/s per lane			
Camera controls	V4L2 controls (Video4Linux Access), Direct Register Access			

¹ See [Mounting the heat sink](#) on page 236.

² Output by `DeviceTemperature`

³ Ensure that the sensor is operated in the temperature range specified by the manufacturer. For any questions, please visit www.alliedvision.com/en/support.

⁴ Temperature values must be observed for the housing **and** for the cooling area.

Table 18: Alvium 1500 C-050m/c specifications (sheet 2 of 2)

Absolute QE

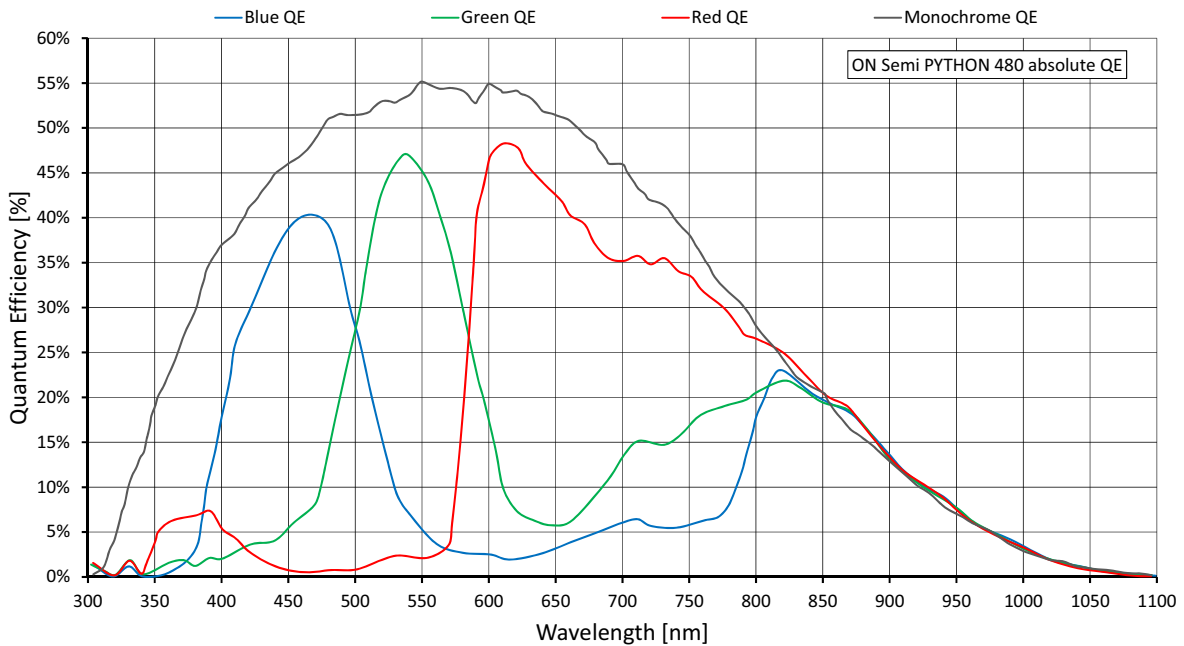

Figure 10: Alvium 1500 C-050m/c (ON Semi PYTHON 480) absolute QE

Spectral response

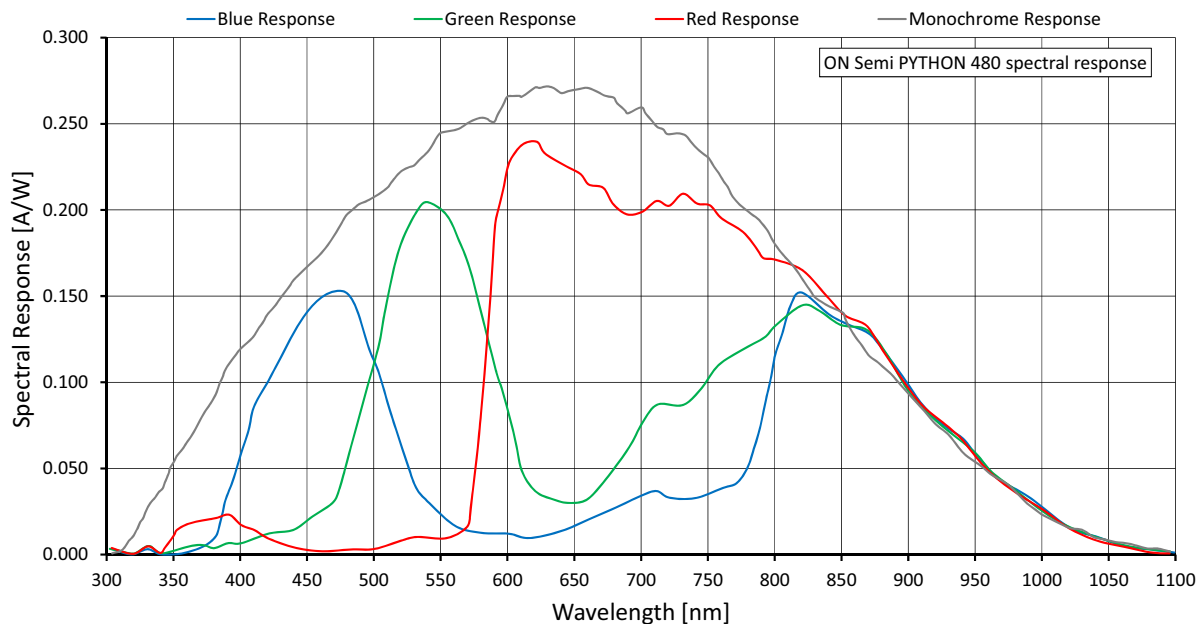

Figure 11: Alvium 1500 C-050m/c (ON Semi PYTHON 480) spectral response

Frame rates with Cropping

Values were calculated as defined in [Frame rates with ROI/Cropping](#) on page 66 and in [Operation for maximum frame rates](#) on page 68.

Frame rates at maximum bandwidth calculates for 1.051 Gbit/s per lane. To reach the maximum frame rate available for typical operation, the bandwidth for image traffic is at 1 lane with 1.051 Gbit/s. Increasing the CSI-2 Lane Count value does not increase frame rates.

Image format	Width [pixels]	Height [pixels]	ROI area [MP]	Frame rate [fps] ¹		
				4-lane	2-lane	1-lane
				4.204 Gbit/s	2.102 Gbit/s	1.051 Gbit/s
Full resolution	808	608	0.491	117.1		
SVGA	800	600	0.480	119.5		
VGA	640	480	0.307	176.7		
HVGA	480	320	0.154	313.6		
QVGA	320	240	0.077	514.1		
HQVGA	240	160	0.038	784.8		
QQVGA	160	120	0.019	1069.7		
Max. × half	808	304	0.246	219.4		
Max. × min.	808	16	0.013	1278.2		
Min. × max.	16	608	0.010	726.5		
Min. × min.	16	16	256 P	1943.8		

¹ RAW8 (GREY) or RGB888 (RGB3) at 10-Bit readout

Table 19: Alvium 1500 C-050m/c ROI frame rates

Alvium 1500 C-120m/c

Feature	Specification	
	1500 C-120m (monochrome)	1500 C-120c (color)
Sensor model	ON Semiconductor AR0135CS	
Resolution	1280 (H) × 960 (V); 1.2 MP	
Sensor type	CMOS	
Shutter type	Global shutter (GS)	
Sensor size	Type 1/3; 4.8 mm × 3.6 mm; 6.0 mm diagonal	
Pixel size	3.75 μm × 3.75 μm	
CRA	0 deg	
ADC bit depth	12-bit	
YUV color pixel formats	Not applicable	YUV422 8-bit (UYVY)
RGB color pixel formats	Default: RGB888 (RGB3)	
RAW pixel formats	RAW8 (GREY), RAW10 (Y10), RAW12 (Y12)	
Maximum frame rate	52 fps ¹ , using 1 to 4 lanes	
Exposure time	57 μs to 1.2 s (1 lane)	
Gain	0 dB to 17.7 dB; 0.1 dB increments	
Digital binning	Horizontal: 1 to 8 columns; Vertical: 1 to 8 rows	
Image buffer (RAM)	256 KByte	
Non-volatile memory (Flash)	1024 KByte	
GPIOs	2 programmable GPIOs As direct inputs (push-pull): 0 to 5.5 VDC As direct outputs (push-pull): 0 to 3.3 VDC at 12 mA	
Power requirements	Power over MIPI CSI-2	
Power consumption (typical, at 5 VDC)	1.1 W	
Storage temperature	-20 °C to +85 °C ambient temperature	

¹ In triggered mode, maximum frame rates require minimum exposure times.

Table 20: Alvium 1500 C-120m/c specifications (sheet 1 of 2)

Feature	Specification			
	1500 C-120m/c			
Operating temperature	Hardware option	Housing	Cooling area ²	Mainboard ³
	Bare board ⁴	Not applicable	-20 °C to +85 °C	-20 °C to +85 °C
	Open housing ⁵	-20 °C to +65 °C		
Relative humidity	0% to 80% (non-condensing)			
Digital interface	MIPI CSI-2 D-PHY V1.1; 1, 2, or 4 lanes; maximum 1.051 Gbit/s per lane			
Camera controls	V4L2 controls (Video4Linux Access), Direct Register Access			
² See Mounting the heat sink on page 236. ³ Output by <code>DeviceTemperature</code> ⁴ Ensure that the sensor is operated in the temperature range specified by the manufacturer. For any questions, please visit www.alliedvision.com/en/support . ⁵ Temperature values must be observed for the housing and for the cooling area.				

Table 20: Alvium 1500 C-120m/c specifications (sheet 2 of 2)

Absolute QE

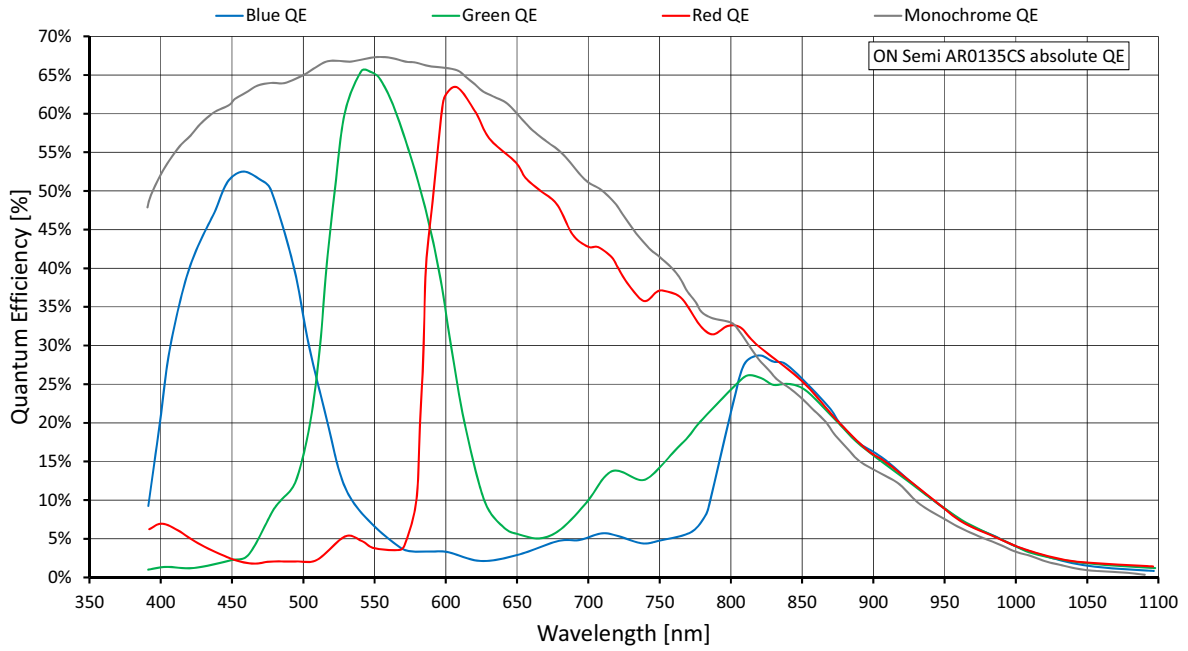

Figure 12: Alvium 1500 C-120m/c (ON Semi AR0135CS) absolute QE

Spectral response

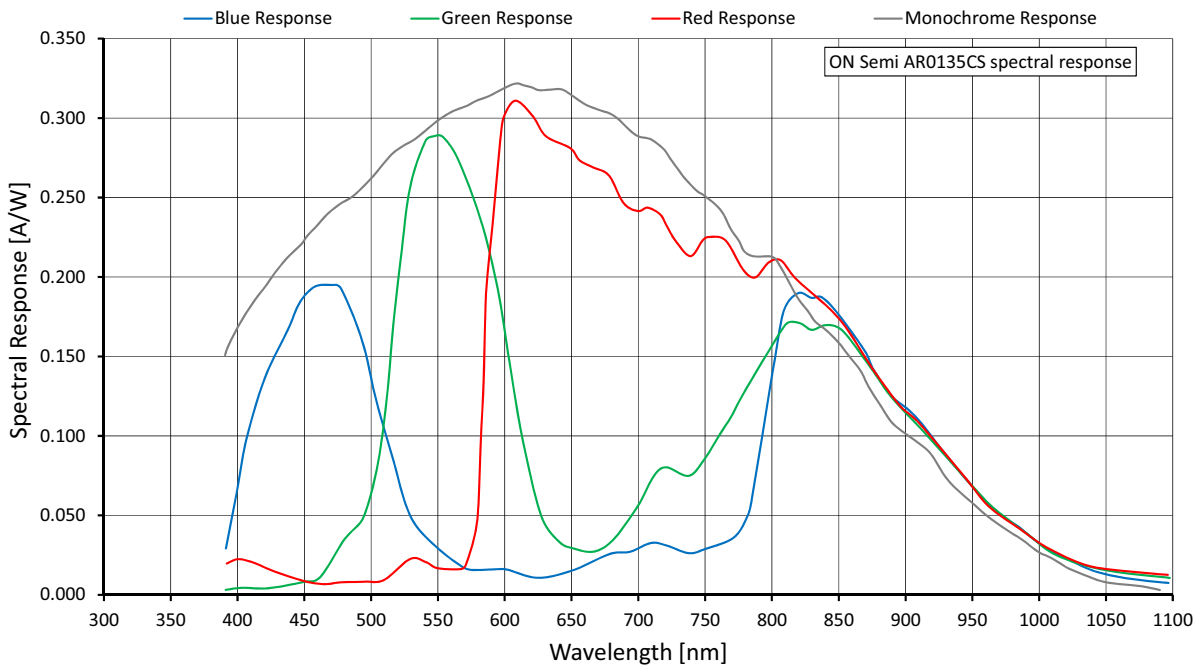

Figure 13: Alvium 1500 C-120m/c (ON Semi AR0135CS) spectral response

Frame rates with Cropping

Values were calculated as defined in [Frame rates with ROI/Cropping](#) on page 66 and in [Operation for maximum frame rates](#) on page 68.

Frame rates at maximum bandwidth calculates for 1.051 Gbit/s per lane. To reach the maximum frame rate available for typical operation, the bandwidth for image traffic is at 1 lane with 1.051 Gbit/s. Increasing the CSI-2 Lane Count value does not increase frame rates.

Alvium 1500 C-120 cameras do not allow overlapping of exposure and readout.

In triggered mode, the maximum available frame rates may be reduced with long exposure times.

Image format	Width [pixels]	Height [pixels]	ROI area [MP]	Frame rate [fps] ¹		
				4-lane	2-lane	1-lane
				4.204 Gbit/s	2.102 Gbit/s	1.051 Gbit/s
Full resolution	1280	960	1.229	52.7		
HD 720	1280	720	0.922	69.1		
XGA	1024	768	0.786	65.1		
SVGA	800	600	0.480	81.9		
VGA	640	480	0.307	100.3		
HVGA	480	320	0.154	143.4		
QVGA	320	240	0.077	160.7		
HQVGA	240	160	0.038	160.8		
QQVGA	160	120	0.019	160.8		
Max. × half	1280	480	0.614	100.3		
Max. × min.	1280	16	0.020	160.4		
Min. × max.	16	960	0.015	52.8		
Min. × min.	16	16	256 P	160.8		

¹ RAW8 (GREY) or RGB888 (RGB3) at 12-Bit readout

Table 21: Alvium 1500 C-120m/c ROI frame rates

Alvium 1500 C-210m/c

Feature	Specification	
	1500 C-210m (monochrome)	1500 C-210c (color)
Sensor model	ON Semiconductor AR0521SR	
Resolution	1928 (H) × 1088 (V); 2.1 MP	
Sensor type	CMOS	
Shutter type	Rolling shutter (RS)	
Sensor size	Type 1/3.6; 4.2 mm × 2.4 mm; 4.9 mm diagonal	
Pixel size	2.2 μm × 2.2 μm	
CRA	9 deg	
ADC bit depth	10-bit	
YUV color pixel formats	Not applicable	YUV422 8-bit (UYVY)
RGB color pixel formats	Default: RGB888 (RGB3)	
RAW pixel formats	RAW8 (GREY), RAW10 (Y10)	
Maximum frame rate	119 fps ¹ , using 2 to 4 lanes	
Exposure time	14 μs to 0.8 s (2 lanes)	
Gain	0 dB to 24.1 dB; 0.1 dB increments	
Digital binning	Horizontal: 1 to 8 columns; Vertical: 1 to 8 rows	
Image buffer (RAM)	256 KByte	
Non-volatile memory (Flash)	1024 KByte	
GPIOs	2 programmable GPIOs As direct inputs (push-pull): 0 to 5.5 VDC As direct outputs (push-pull): 0 to 3.3 VDC at 12 mA	
Power requirements	Power over MIPI CSI-2	
Power consumption (typical, at 5 VDC)	1.9 W	
Storage temperature	-20 °C to +85 °C ambient temperature	
¹ In triggered mode: ~59 fps		

Table 22: Alvium 1500 C-210m/c specifications (sheet 1 of 2)

Feature	Specification			
	1500 C-210m/c			
Operating temperature	Hardware option	Housing	Cooling area ²	Mainboard ³
	Bare board ⁴	Not applicable	-20 °C to +85 °C	-20 °C to +85 °C
	Open housing ⁵	-20 °C to +65 °C		
Relative humidity	0% to 80% (non-condensing)			
Digital interface	MIPI CSI-2 D-PHY V1.1; 1, 2, or 4 lanes; maximum 1.051 Gbit/s per lane			
Camera controls	V4L2 controls (Video4Linux Access), Direct Register Access			
² See Mounting the heat sink on page 236. ³ Output by <code>DeviceTemperature</code> ⁴ Ensure that the sensor is operated in the temperature range specified by the manufacturer. For any questions, please visit www.alliedvision.com/en/support . ⁵ Temperature values must be observed for the housing and for the cooling area.				

Table 22: Alvium 1500 C-210m/c specifications (sheet 2 of 2)

Absolute QE

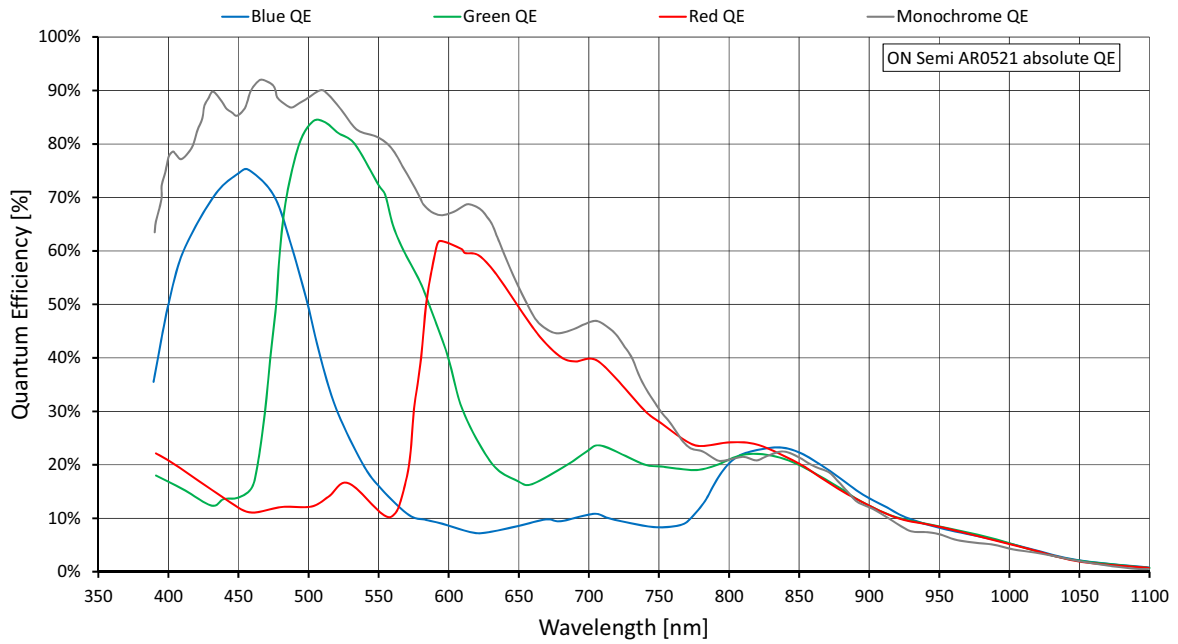

Figure 14: Alvium 1500 C-210m/c (ON Semi AR0521HD) absolute QE

Spectral response

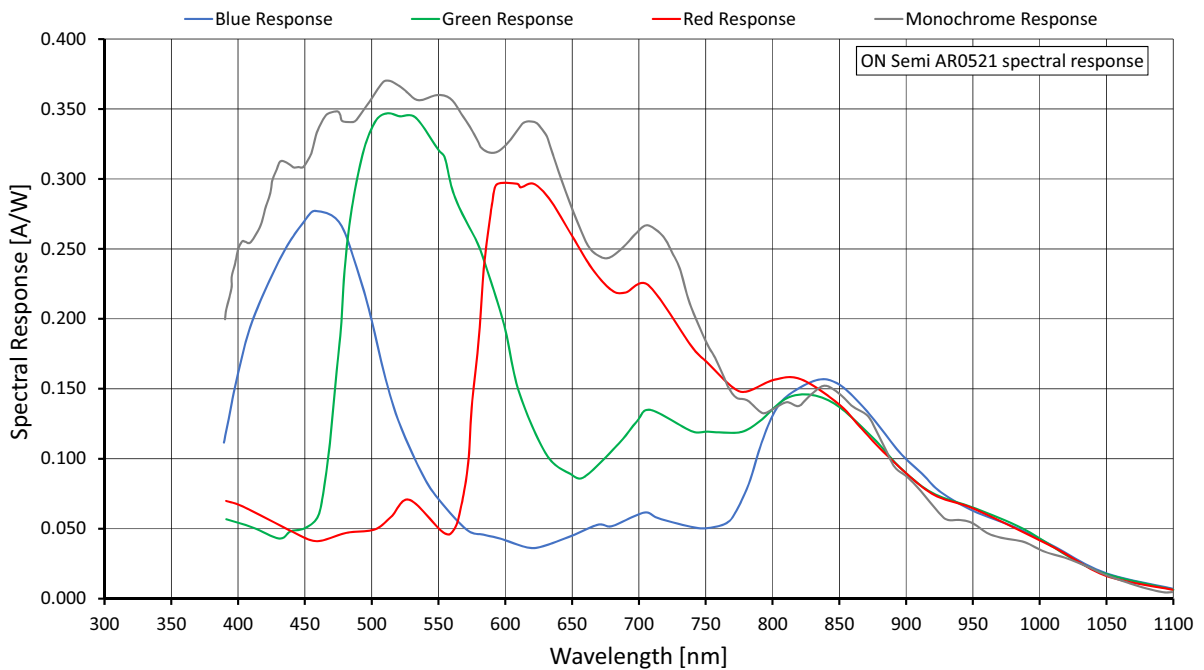

Figure 15: Alvium 1500 C-210m/c (ON Semi AR0521HD) spectral response

Frame rates with Cropping

Values were calculated as defined in [Frame rates with ROI/Cropping](#) on page 66 and in [Operation for maximum frame rates](#) on page 68.

Frame rates at maximum bandwidth calculates for 1.051 Gbit/s per lane. To reach the maximum frame rate available for typical operation, the bandwidth for image traffic is at 2 lanes with 2.102 Gbit/s. Increasing the CSI-2 Lane Count value does not increase frame rates.

Shutter mode	User mode	Available frame rates
Rolling shutter (RS)	Freerun	Values in Table 24 below are reached.
Rolling shutter (RS)	Triggered	>50% of the values for in Table 24 below are reached.

Table 23: Frame rate behavior for different configurations

Image format	Width [pixels]	Height [pixels]	ROI area [MP]	Frame rate [fps] ¹		
				4-lane	2-lane	1-lane
				4.204 Gbit/s	2.102 Gbit/s	1.051 Gbit/s
Full resolution	1928	1088	2.098	119.6		60.2
Full HD	1920	1080	2.074	120.5		60.9
WXGA+ ²	1440	904	1.302	143.2		96.3
SXGA	1280	1024	1.311	127.2		96.2
HD 720	1280	720	0.922	177.7		134.5
XGA	1024	768	0.786	167.7		158.1
SVGA	800	600	0.480		212.1	
VGA	640	480	0.307		261.3	
HVGA	480	320	0.154		378.2	
QVGA	320	240	0.077		488.0	
HQVGA	240	160	0.038		684.2	
QQVGA	160	120	0.019		856.3	
Max. × half	1928	544	1.049	229.2		116.0
Max. × min.	1928	16	0.031	2062.4		1154.5
Min. × max.	16	1088	0.017		120.8	
Min. × min.	16	16	256 P		2474.6	

¹ RAW8 (GREY) or RGB888 (RGB3) at 10-Bit readout

² Instead of 1,440 × 900

If resolutions were not available due to increments, frame rates relate to the next available resolution.

Table 24: Alvim 1500 C-210m/c ROI frame rates

Alvium 1500 C-500m/c

Feature	Specification	
	1500 C-500m (monochrome)	1500 C-500c (color)
Sensor model	ON Semiconductor AR0521SR	
Resolution	2592 (H) × 1944 (V); 5.0 MP	
Sensor type	CMOS	
Shutter type	Rolling shutter (RS)	
Sensor size	Type 1/2.5; 5.7 mm × 4.3 mm; 7.1 mm diagonal	
Pixel size	2.2 μm × 2.2 μm	
CRA	9 deg	
ADC bit depth	10-bit	
YUV color pixel formats	Not applicable	YUV422 8-bit (UYVY)
RGB color pixel formats	Default: RGB888 (RGB3)	
RAW pixel formats	RAW8 (GREY), RAW10 (Y10)	
Maximum frame rate	68 fps ¹ , using 4 lanes	
Exposure time	14 μs to 0.8 s (4 lanes)	
Gain	0 dB to 24.1 dB; 0.1 dB increments	
Digital binning	Horizontal: 1 to 8 columns; Vertical: 1 to 8 rows	
Image buffer (RAM)	256 KByte	
Non-volatile memory (Flash)	1024 KByte	
GPIOs	2 programmable GPIOs As direct inputs (push-pull): 0 to 5.5 VDC As direct outputs (push-pull): 0 to 3.3 VDC at 12 mA	
Power requirements	Power over MIPI CSI-2	
Power consumption (typical, at 5 VDC)	1.9 W	
Storage temperature	-20 °C to +85 °C ambient temperature	
¹ In triggered mode: ~34 fps		

Table 25: Alvium 1500 C-500m/c specifications (sheet 1 of 2)

Feature	Specification			
	1500 C-500m/c			
Operating temperature	Hardware option	Housing	Cooling area ²	Mainboard ³
	Bare board ⁴	Not applicable	-20 °C to +85 °C	-20 °C to +85 °C
	Open housing ⁵	-20 °C to +65 °C		
Relative humidity	0% to 80% (non-condensing)			
Digital interface	MIPI CSI-2 D-PHY V1.1; 1, 2, or 4 lanes; maximum 1.051 Gbit/s per lane			
Camera controls	V4L2 controls (Video4Linux Access), Direct Register Access			
² See Mounting the heat sink on page 236. ³ Output by <code>DeviceTemperature</code> ⁴ Ensure that the sensor is operated in the temperature range specified by the manufacturer. For any questions, please visit www.alliedvision.com/en/support . ⁵ Temperature values must be observed for the housing and for the cooling area.				

Table 25: Alvium 1500 C-500m/c specifications (sheet 2 of 2)

Absolute QE

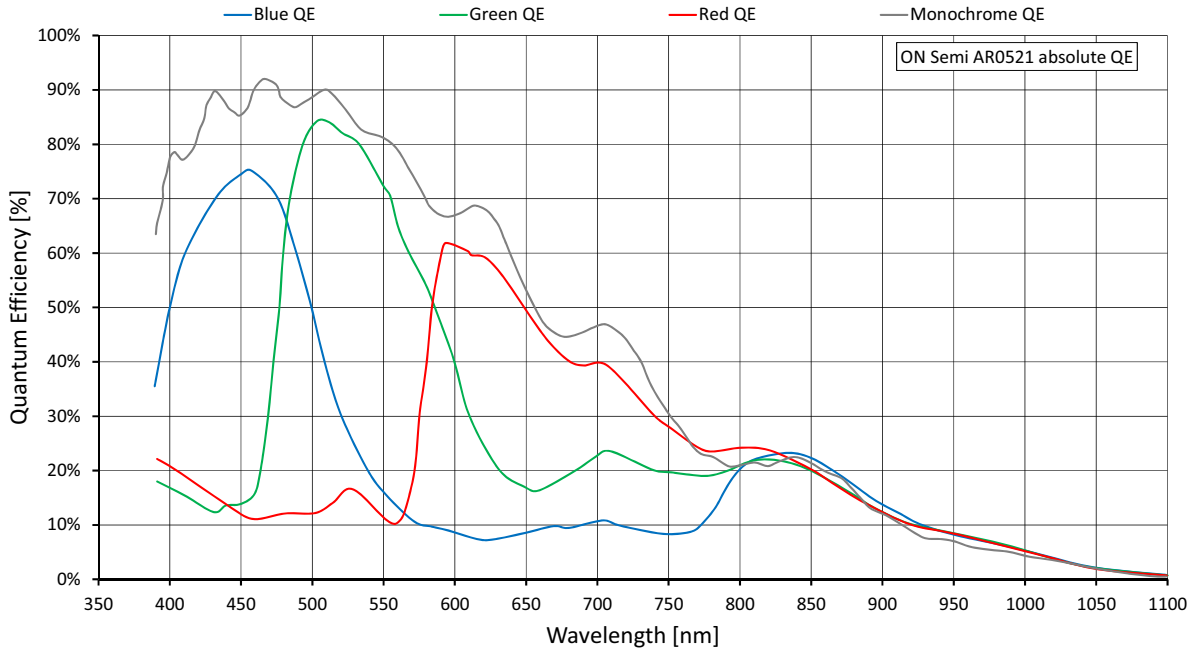

Figure 16: Alvium 1500 C-500m/c (ON Semi AR0521SR) absolute QE

Spectral response

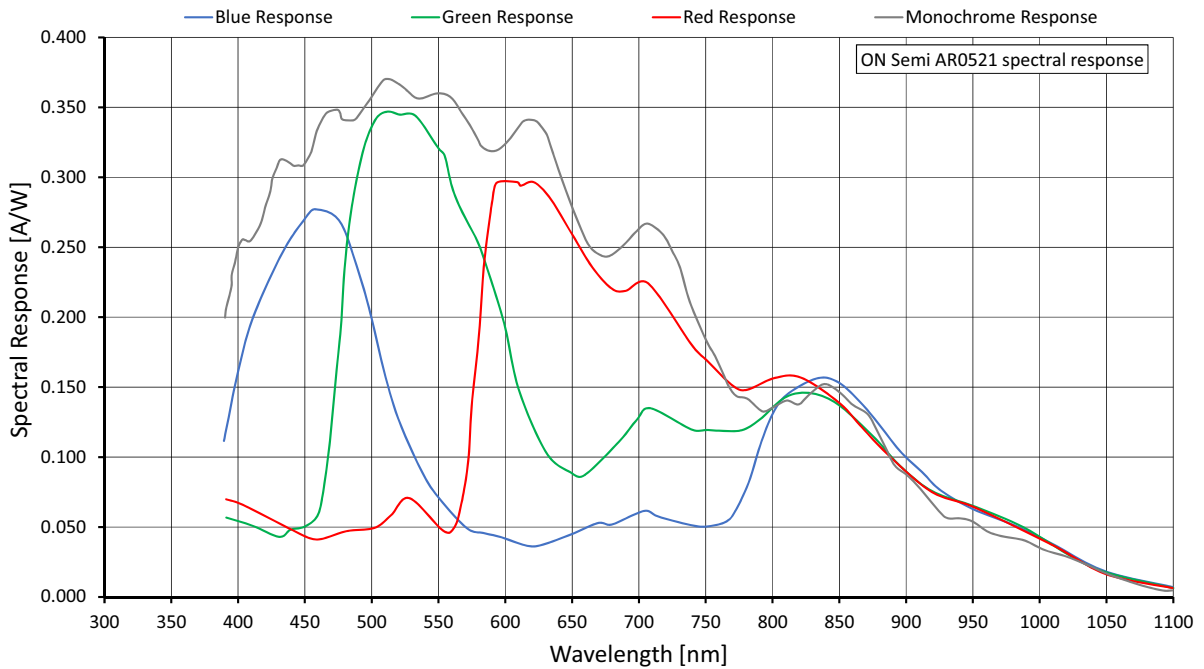

Figure 17: Alvium 1500 C-500m/c (ON Semi AR0521SR) spectral response

Frame rates with Cropping

Values were calculated as defined in [Frame rates with ROI/Cropping](#) on page 66 and in [Operation for maximum frame rates](#) on page 68.

Frame rates at maximum bandwidth calculates for 1.051 Gbit/s per lane. To reach the maximum frame rate available for typical operation, the bandwidth for image traffic is at 4 lanes with 4.204 Gbit/s.

Shutter mode	User mode	Available frame rates
Rolling shutter (RS)	Freerun	Values in Table 27 below are reached.
Rolling shutter (RS)	Triggered	>50% of the values for in Table 27 below are reached.

Table 26: Frame rate behavior for different configurations

Image format	Width [pixels]	Height [pixels]	ROI area [MP]	Frame rate [fps] ¹		
				4-lane	2-lane	1-lane
				4.204 Gbit/s	2.102 Gbit/s	1.051 Gbit/s
Full resolution	2592	1944	5.039	68.1	50.8	25.5
WQHD	2560	1440	3.686	91.1	68.9	34.6
QXGA	2048	1536	3.146	85.8	80.8	40.6
Full HD	1920	1080	2.074	120.5		60.9
UXGA	1600	1200	1.920	109.1		66.0
WXGA+ ²	1440	904	1.302	143.2		96.3
SXGA	1280	1024	1.311	127.2		96.2
HD 720	1280	720	0.922	177.7		134.5
XGA	1024	768	0.786	167.7		158.1
SVGA	800	600	0.480	212.1		
VGA	640	480	0.307	261.3		
HVGA	480	320	0.154	378.2		
QVGA	320	240	0.077	488.0		
HQVGA	240	160	0.038	684.2		
QQVGA	160	120	0.019	856.3		
Max. × half ³	2592	976	2.530	132.0	98.8	49.7
Max. × min.	2592	16	0.041	1917.2	1535.3	858.9
Min. × max.	16	1944	0.031	68.6		
Min. × min.	16	16	256 P	2474.6		

¹ RAW8 (GREY) or RGB888 (RGB3) at 10-Bit readout

² Instead of 1,440 × 900

³ Instead of 2,592 × 972

If resolutions were not available due to increments, frame rates relate to the next available resolution.

Table 27: Alvium 1500 C-500m/c ROI frame rates

Alvium 1500 C-501m/c NIR

Feature	Specification	
	1500 C-501m NIR (monochrome)	1500 C-501c NIR (color)
Sensor model	ON Semiconductor AR0522	
Resolution	2592 (H) × 1944 (V); 5.0 MP	
Sensor type	CMOS	
Shutter type	Rolling shutter (RS)	
Sensor size	Type 1/2.5; 5.7 mm × 4.3 mm; 7.1 mm diagonal	
Pixel size	2.2 μm × 2.2 μm	
CRA	9 deg	
ADC bit depth	10-bit	
YUV color pixel formats	Not applicable	YUV422 8-bit (UYVY)
RGB color pixel formats	Default: RGB888 (RGB3)	
RAW pixel formats	RAW8 (GREY), RAW10 (Y10)	
Maximum frame rate	68 fps ¹ , using 4 lanes	
Exposure time	14 μs to 0.8 s (4 lanes)	
Gain	0 dB to 24.1 dB; 0.1 dB increments	
Digital binning	Horizontal: 1 to 8 columns; Vertical: 1 to 8 rows	
Image buffer (RAM)	256 KByte	
Non-volatile memory (Flash)	1024 KByte	
GPIOs	2 programmable GPIOs As direct inputs (push-pull): 0 to 5.5 VDC As direct outputs (push-pull): 0 to 3.3 VDC at 12 mA	
Power requirements	Power over MIPI CSI-2	
Power consumption (typical, at 5 VDC)	1.9 W	
Storage temperature	-20 °C to +85 °C ambient temperature	
¹ In triggered mode: ~34 fps		

Table 28: Alvium 1500 C-501m/c NIR specifications (sheet 1 of 2)

Feature	Specification			
	1500 C-501m/c NIR			
Operating temperature	Hardware option	Housing	Cooling area²	Mainboard³
	Bare board ⁴	Not applicable	-20 °C to +85 °C	-20 °C to +85 °C
	Open housing ⁵	-20 °C to +65 °C		
Relative humidity	0% to 80% (non-condensing)			
Digital interface	MIPI CSI-2 D-PHY V1.1; 1, 2, or 4 lanes; maximum 1.051 Gbit/s per lane			
Camera controls	V4L2 controls (Video4Linux Access), Direct Register Access			
² See Mounting the heat sink on page 236. ³ Output by <code>DeviceTemperature</code> ⁴ Ensure that the sensor is operated in the temperature range specified by the manufacturer. For any questions, please visit www.alliedvision.com/en/support . ⁵ Temperature values must be observed for the housing and for the cooling area.				

Table 28: Alvium 1500 C-501m/c NIR specifications (sheet 2 of 2)

Absolute QE

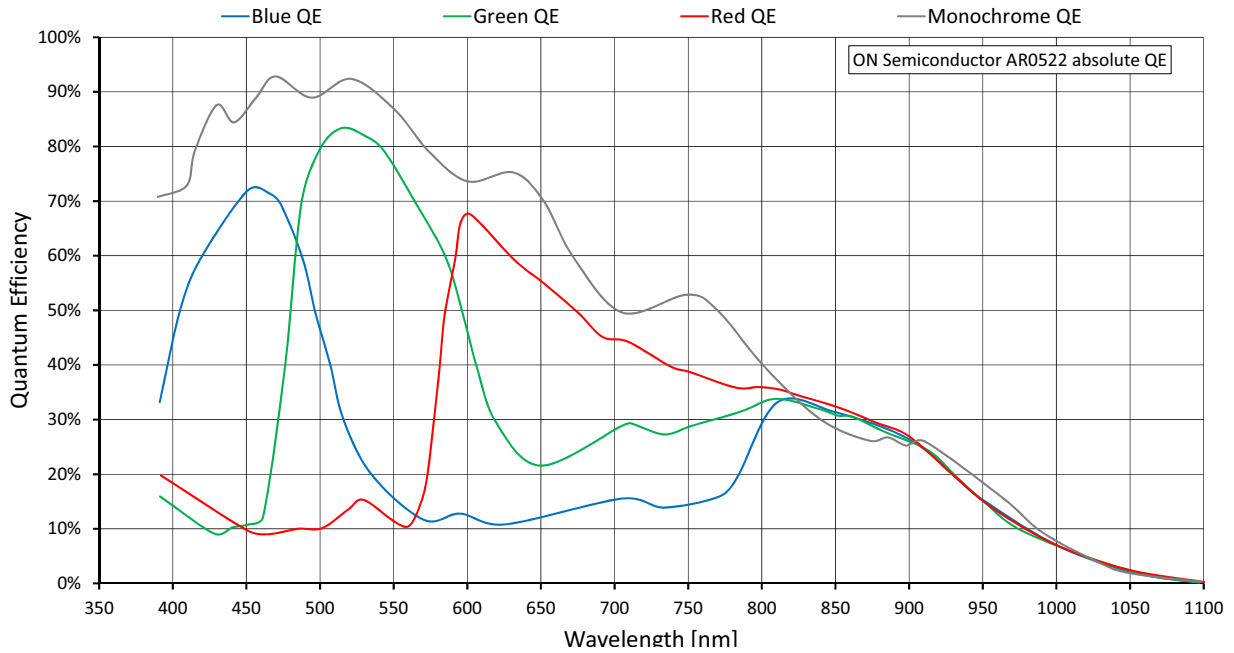

Figure 18: Alvium 1500 C-501m/c NIR (ON Semi AR0522) absolute QE

Spectral response

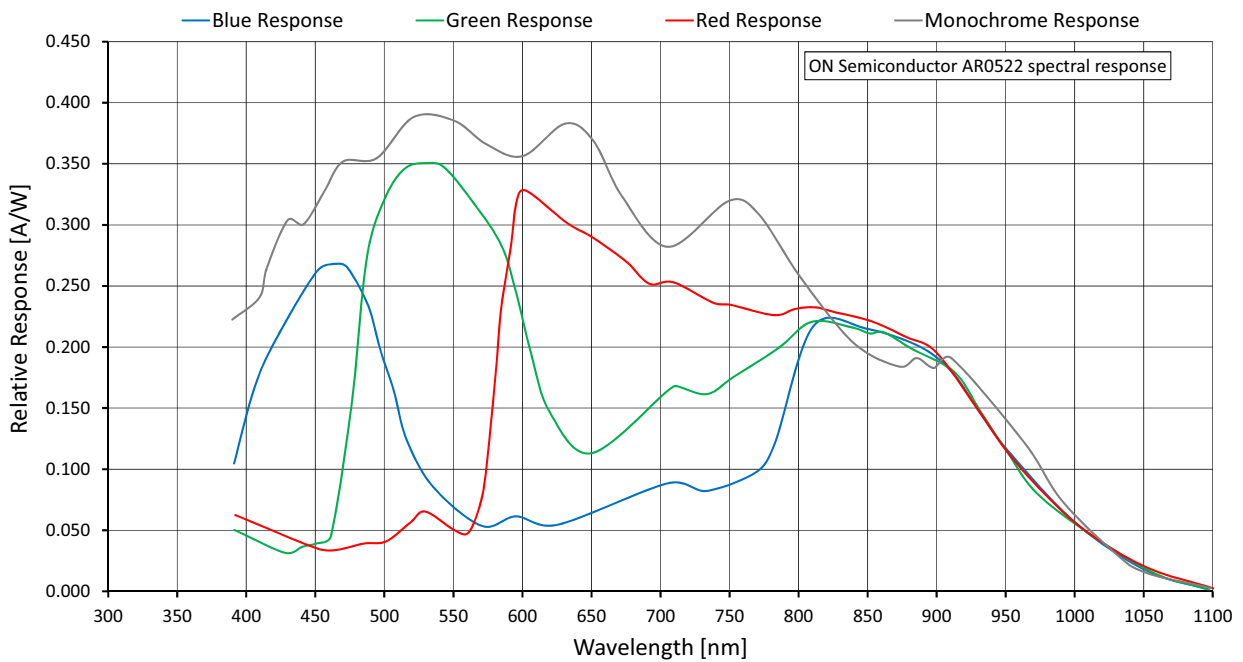

Figure 19: Alvium 1500 C-501m/c NIR (ON Semi AR0522) spectral response

Frame rates with Cropping

Values were calculated as defined in [Frame rates with ROI/Cropping](#) on page 66 and in [Operation for maximum frame rates](#) on page 68.

Frame rates at maximum bandwidth calculates for 1.051 Gbit/s per lane. To reach the maximum frame rate available for typical operation, the bandwidth for image traffic is at 4 lanes with 4.204 Gbit/s.

Shutter mode	User mode	Available frame rates
Rolling shutter (RS)	Freerun	Values in Table 30 below are reached.
Rolling shutter (RS)	Triggered	>50% of the values for in Table 30 below are reached.

Table 29: Frame rate behavior for different configurations

Image format	Width [pixels]	Height [pixels]	ROI area [MP]	Frame rate [fps] ¹		
				4-lane	2-lane	1-lane
				4.204 Gbit/s	2.102 Gbit/s	1.051 Gbit/s
Full resolution	2592	1944	5.039	68.1	50.8	25.5
WQHD	2560	1440	3.686	91.1	68.9	34.6
QXGA	2048	1536	3.146	85.8	80.8	40.6
Full HD	1920	1080	2.074	120.5		60.9
UXGA	1600	1200	1.920	109.1		66.0
WXGA+ ²	1440	904	1.302	143.2		96.3
SXGA	1280	1024	1.311	127.2		96.2
HD 720	1280	720	0.922	177.7		134.5
XGA	1024	768	0.786	167.7		158.1
SVGA	800	600	0.480	212.1		
VGA	640	480	0.307	261.3		
HVGA	480	320	0.154	378.2		
QVGA	320	240	0.077	488.0		
HQVGA	240	160	0.038	684.2		
QQVGA	160	120	0.019	856.3		
Max. × half ³	2592	976	2.530	132.0	98.8	49.7
Max. × min.	2592	16	0.041	1917.2	1535.3	858.9
Min. × max.	16	1944	0.031	68.6		
Min. × min.	16	16	256 P	2474.6		

¹ RAW8 (GREY) or RGB888 (RGB3) at 10-Bit readout
² Instead of 1,440 × 900
³ Instead of 2,592 × 972
 If resolutions were not available due to increments, frame rates relate to the next available resolution.

Table 30: Alvium 1500 C-501m/c NIR ROI frame rates

Alvium 1800 C model specifications



Alvium 1800 C-030 VSWIR

Red table border lines signal that **GenICam for CSI-2 Access** is required.

Feature	Specification
	1800 C-030 VSWIR
Sensor model	Sony IMX991
Resolution	656 (H) × 520 (V); 0.3 MP
Sensor type	InGaAs
Shutter type	Global shutter (GS)
Sensor size	Type 1/4; 3.28 mm × 2.6 mm; 4.1 mm diagonal
Pixel size	5 μm × 5 μm
CRA	0 deg
Sensor bit depth (ADC)	8-bit, 10-bit, 12-bit; Adaptive (10-bit, 12-bit)
Sensor bit depth (ADC)	12-bit
	Pixel formats, GenICam for CSI-2 Access
Monochrome pixel formats	Mono8 (default), Mono10, Mono10p, Mono12, Mono12p
	Pixel formats, other access modes
RAW pixel formats	RAW8 (GREY), RAW10 (Y10), RAW12 (Y12)
Maximum frame rate	132 fps, using 1 to 4 lanes
Exposure time	34 μs to 10 s (1 lane)
Exposure modes	Timed, TriggerControlled, TriggerWidth
Gain	0 dB to 42 dB; 0.1 dB increments
Digital binning	Horizontal: 1 to 8 columns; Vertical: 1 to 8 rows
Image buffer (RAM)	256 KByte
Non-volatile memory (Flash)	1024 KByte
GPIOs	2 programmable GPIOs As direct inputs (push-pull): 0 to 5.5 VDC As direct outputs (push-pull): 0 to 3.3 VDC at 12 mA
Power requirements	Power over MIPI CSI-2
Power consumption (typical, at 5 VDC)	1.8 W

Table 31: Alvium 1800 C-030 VSWIR specifications (sheet 1 of 2)

Feature	Specification			
	1800 C-030 VSWIR			
Storage temperature	-20 °C to +85 °C ambient temperature			
Operating temperature	Hardware option	Housing	Cooling area¹	Mainboard²
	Bare board ³	Not applicable	-20 °C to +85 °C	-20 °C to +85 °C
	Open housing ⁴	-20 °C to +65 °C		
Relative humidity	0% to 80% (non-condensing)			
Digital interface	MIPI CSI-2 D-PHY V1.1; 1, 2, or 4 lanes; maximum 1.051 Gbit/s per lane			
Camera controls	GenICam (GenICam for CSI-2 Access)			
	V4L2 controls (Video4Linux Access), Direct Register Access			

¹ See [Mounting the heat sink](#) on page 236.

² Output by DeviceTemperature

³ Ensure that the sensor is operated in the temperature range specified by the manufacturer. For any questions, please visit www.alliedvision.com/en/support.

⁴ Temperature values must be observed for the housing **and** for the cooling area.

Table 31: Alvim 1800 C-030 VSWIR specifications (sheet 2 of 2)

Relative QE

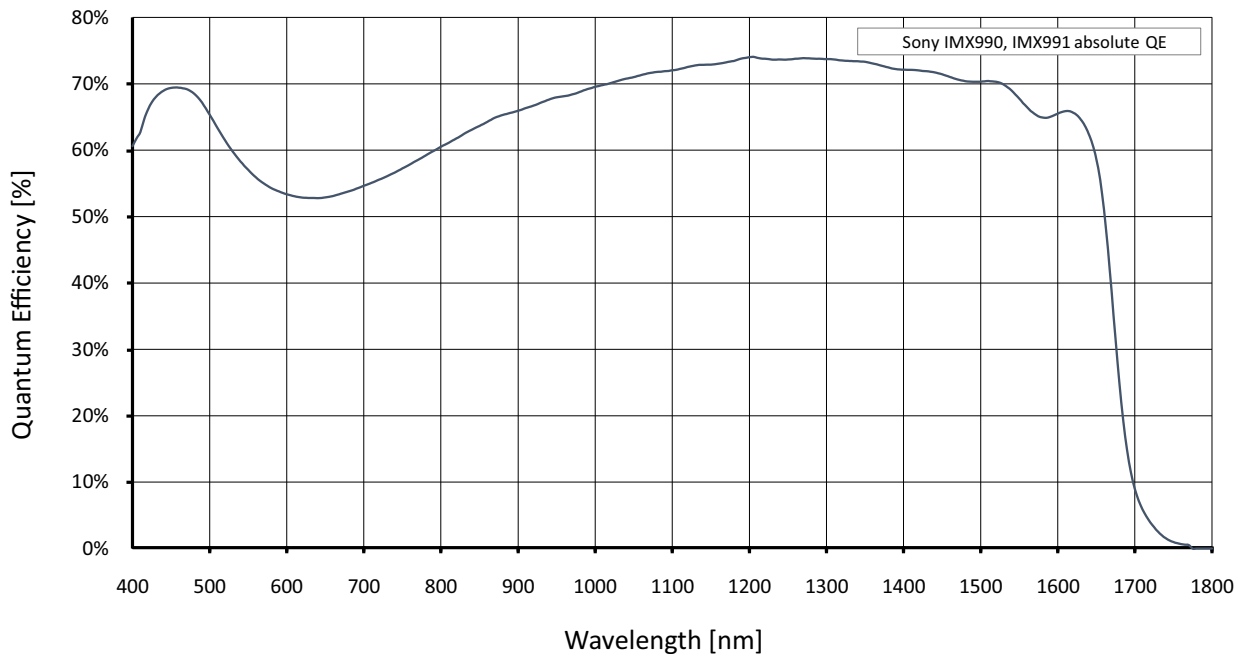

Figure 20: Alvim 1800 C-030 VSWIR (Sony IMX991) relative QE

Frame rates with Cropping

Values were calculated as defined in [Frame rates with ROI/Cropping](#) on page 66 and in [Operation for maximum frame rates](#) on page 68.

Frame rates at maximum bandwidth calculates for 1.051 Gbit/s per lane. To reach the maximum frame rate available for typical operation, the bandwidth for image traffic is at 1 lane with 1.051 Gbit/s. Increasing the CSI-2 Lane Count value does not increase frame rates.

Image format	Width [pixels]	Height [pixels]	ROI area [MP]	Frame rate [fps] ¹		
				4-lane	2-lane	1-lane
				4.204 Gbit/s	2.102 Gbit/s	1.051 Gbit/s
Full resolution	656	520	0.341	132.9		
VGA	640	480	0.307	142.9		
HVGA	480	320	0.154	205.1		
QVGA	320	240	0.077	262.7		
HQVGA	240	160	0.038	365.0		
QQVGA	160	120	0.019	454.6		
Max. × half ²	656	264	0.173	241.0		
Max. × min.	656	16	0.010	1133.1		
Min. × max.	16	520	0.008	134.1		
Min. × min.	16	16	256 P	1224.5		

¹ RAW8 (GREY) at 12-Bit readout
² Instead of 656 × 260
 If resolutions were not available due to increments, frame rates relate to the next available resolution.

Table 32: Alvim 1800 C-030 VSWIR ROI frame rates



Maximum frame rates with SensorBitDepth

Alvim 1800 C-030 VSWIR can run higher frame rates than with ADC bit depth when SensorBitDepth is enabled. These values will be added in a future version of this document.



Alvium 1800 C-040m/c

Red table border lines signal that **GenICam for CSI-2 Access** is required.

Feature	Specification	
	1800 C-040m (monochrome)	1800 C-040c (color)
Sensor model	Sony IMX287	
Resolution	728 (H) × 544 (V); 0.4 MP	
Sensor type	CMOS	
Shutter type	Global shutter (GS)	
Sensor size	Type 1/2.9; 5 mm × 3.8 mm; 6.3 mm diagonal	
Pixel size	6.9 μm × 6.9 μm	
CRA	0 deg	
Sensor bit depth (ADC)	8-bit, 10-bit, 12-bit; Adaptive (10-bit, 12-bit)	
Sensor bit depth (ADC)	12-bit	
Pixel formats, GenICam for CSI-2 Access		
Monochrome pixel formats	Mono8 (default), Mono10, Mono10p, Mono12, Mono12p	Mono8, Mono10, Mono10p, Mono12, Mono12p
YUV color pixel formats	Not applicable	YCbCr411_8_CbYYCrYY, YCbCr422_8_CbYCrY, YCbCr8_CbYCr
RGB color pixel formats	Not applicable	BGR8, RGB8 (default)
Raw color pixel formats	Not applicable	BayerRG8, BayerRG10, BayerRG10p, BayerRG12, BayerRG12p
Pixel formats, other access modes		
YUV color pixel formats	Not applicable	YUV422 8-bit (UYVY)
RGB color pixel formats	Default: RGB888 (RGB3)	
RAW pixel formats	RAW8 (GREY), RAW10 (Y10), RAW12 (Y12)	
Maximum frame rate	302 fps, using 2 to 4 lanes	
Exposure time	26 μs to 10 s (2 lanes)	
Exposure modes	Timed, TriggerControlled, TriggerWidth	
Gain	0 dB to 48 dB; 0.1 dB increments	
Digital binning	Horizontal: 1 to 8 columns; Vertical: 1 to 8 rows	
Image buffer (RAM)	256 KByte	
Non-volatile memory (Flash)	1024 KByte	
GPIOs	2 programmable GPIOs As direct inputs (push-pull): 0 to 5.5 VDC As direct outputs (push-pull): 0 to 3.3 VDC at 12 mA	
Power requirements	Power over MIPI CSI-2	

Table 33: Alvium 1800 C-040m/c specifications (sheet 1 of 2)

Feature	Specification			
	1800 C-040m/c			
Power consumption (typical, at 5 VDC)	1.7 W			
Storage temperature	-20 °C to +85 °C ambient temperature			
Operating temperature	Hardware option	Housing	Cooling area¹	Mainboard²
	Bare board ³	Not applicable	-20 °C to +85 °C	-20 °C to +85 °C
	Open housing ⁴	-20 °C to +65 °C		
Relative humidity	0% to 80% (non-condensing)			
Digital interface	MIPI CSI-2 D-PHY V1.1; 1, 2, or 4 lanes; maximum 1.051 Gbit/s per lane			
Camera controls	GenICam (GenICam for CSI-2 Access)			
	V4L2 controls (Video4Linux Access), Direct Register Access			
¹ See Mounting the heat sink on page 236. ² Output by <code>DeviceTemperature</code> ³ Ensure that the sensor is operated in the temperature range specified by the manufacturer. For any questions, please visit www.alliedvision.com/en/support . ⁴ Temperature values must be observed for the housing and for the cooling area.				

Table 33: Alvium 1800 C-040m/c specifications (sheet 2 of 2)

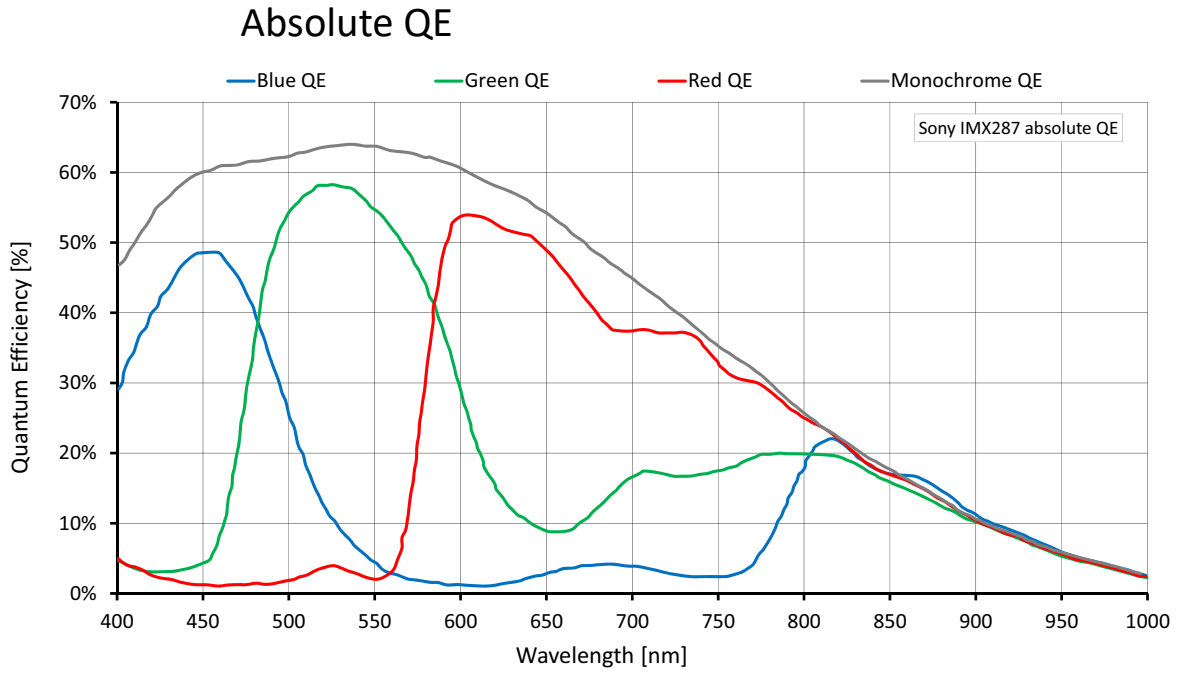

Figure 21: Alvium 1800 C-040m/c (Sony IMX287) absolute QE

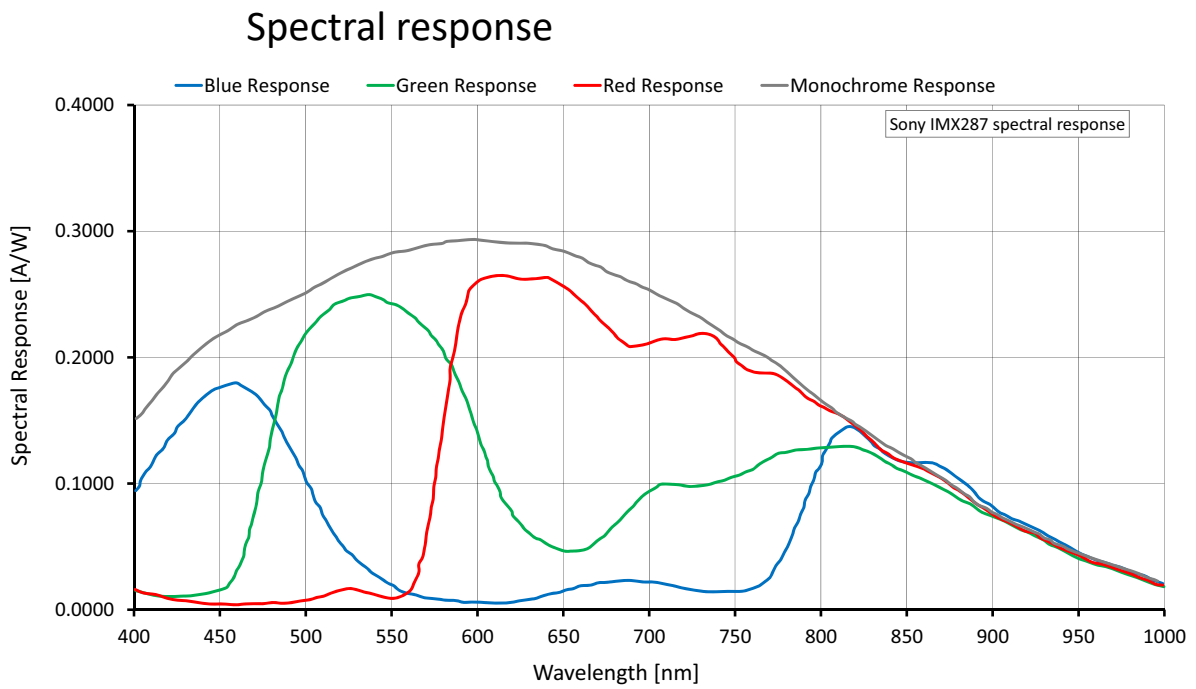

Figure 22: Alvium 1800 C-040m/c (Sony IMX287) spectral response

Frame rates with Cropping

Values were calculated as defined in [Frame rates with ROI/Cropping](#) on page 66 and in [Operation for maximum frame rates](#) on page 68.

Frame rates at maximum bandwidth calculates for 1.051 Gbit/s per lane. To reach the maximum frame rate available for typical operation, the bandwidth for image traffic is at 2 lanes with 2.102 Gbit/s. Increasing the CSI-2 Lane Count value does not increase frame rates.

Image format	Width [pixels]	Height [pixels]	ROI area [MP]	Frame rate [fps] ¹		
				4-lane	2-lane	1-lane
				4.204 Gbit/s	2.102 Gbit/s	1.051 Gbit/s
Full resolution	728	544	0.396	302.2		294.0
VGA	640	480	0.307	338.9		
HVGA	480	320	0.154	483.5		
QVGA	320	240	0.077	617.7		
HQVGA	240	160	0.038	847.2		
QQVGA	160	120	0.019	1037.6		
Max. x half	728	272	0.198	544.8		530.6
Max. x min.	728	16	0.012	2225.3		2187.1
Min. x max.	16	544	0.009	306.8		
Min. x min.	16	16	256 P	2495.9		

¹ RAW8 (GREY) or RGB888 (RGB3) at 12-Bit readout

Table 34: Alvium 1800 C-040m/c ROI frame rates



Maximum frame rates with SensorBitDepth

Alvium 1800 C-040 can run higher frame rates than with ADC bit depth when **SensorBitDepth** is enabled. These values will be added in a future version of this document.



Alvium 1800 C-052m/c

Red table border lines signal that **GeniCam for CSI-2 Access** is required.

Feature	Specification	
	1800 C-052m (monochrome)	1800 C-052c (color)
Sensor model	Sony IMX426	
Resolution	816 (H) × 624 (V); 0.5 MP	
Sensor type	CMOS	
Shutter type	Global shutter (GS)	
Sensor size	Type 1/1.7; 7.3 mm × 5.6 mm; 9.2 mm diagonal	
Pixel size	9.0 μm × 9.0 μm	
CRA	0 deg	
Sensor bit depth (ADC)	8-bit, 10-bit, 12-bit; Adaptive (10-bit, 12-bit)	
Sensor bit depth (ADC)	12-bit	
Pixel formats, GeniCam for CSI-2 Access		
Monochrome pixel formats	Mono8 (default), Mono10, Mono10p, Mono12, Mono12p	Mono8, Mono10, Mono10p, Mono12, Mono12p
YUV color pixel formats	Not applicable	YCbCr411_8_CbYYCrYY, YCbCr422_8_CbYCrY, YCbCr8_CbYCr
RGB color pixel formats	Not applicable	BGR8, RGB8 (default)
Raw color pixel formats	Not applicable	BayerRG8, BayerRG10, BayerRG10p, BayerRG12, BayerRG12p
Pixel formats, other access modes		
YUV color pixel formats	Not applicable	YUV422 8-bit (UYVY)
RGB color pixel formats	Default: RGB888 (RGB3)	
RAW pixel formats	RAW8 (GREY), RAW10 (Y10), RAW12 (Y12)	
Maximum frame rate	499 fps, using 4 lanes	
Exposure time	21 μs to 10 s (4 lanes)	
Exposure modes	Timed, TriggerControlled, TriggerWidth	
Gain	0 dB to 48 dB; 0.1 dB increments	
Digital binning	Horizontal: 1 to 8 columns; Vertical: 1 to 8 rows	
Image buffer (RAM)	256 KByte	
Non-volatile memory (Flash)	1024 KByte	
GPIOs	2 programmable GPIOs As direct inputs (push-pull): 0 to 5.5 VDC As direct outputs (push-pull): 0 to 3.3 VDC at 12 mA	
Power requirements	Power over MIPI CSI-2	

Table 35: Alvium 1800 C-052m/c specifications (sheet 1 of 2)

Feature	Specification			
	1800 C-052m/c			
Power consumption (typical, at 5 VDC)	3.8 W			
Storage temperature	-20 °C to +85 °C ambient temperature			
Operating temperature	Hardware option	Housing	Cooling area¹	Mainboard²
	Bare board ³	Not applicable	-20 °C to +85 °C	-20 °C to +85 °C
	Open housing ⁴	-20 °C to +65 °C		
Relative humidity	0% to 80% (non-condensing)			
Digital interface	MIPI CSI-2 D-PHY V1.1; 1, 2, or 4 lanes; maximum 1.051 Gbit/s per lane			
Camera controls	GenICam (GenICam for CSI-2 Access)			
	V4L2 controls (Video4Linux Access), Direct Register Access			
¹ See Mounting the heat sink on page 236. ² Output by DeviceTemperature ³ Ensure that the sensor is operated in the temperature range specified by the manufacturer. For any questions, please visit www.alliedvision.com/en/support . ⁴ Temperature values must be observed for the housing and for the cooling area.				

Table 35: Alvium 1800 C-052m/c specifications (sheet 2 of 2)

Absolute QE, spectral response

Diagrams will be added in a future version of this document.

Frame rates with Cropping

Values were calculated as defined in [Frame rates with ROI/Cropping](#) on page 66 and in [Operation for maximum frame rates](#) on page 68.

Frame rates at maximum bandwidth calculates for 1.051 Gbit/s per lane. To reach the maximum frame rate available for typical operation, the bandwidth for image traffic is at 4 lanes with 4.204 Gbit/s.

Image format	Width [pixels]	Height [pixels]	ROI area [MP]	Frame rate [fps] ¹		
				4-lane	2-lane	1-lane
				4.204 Gbit/s	2.102 Gbit/s	1.051 Gbit/s
Full resolution	816	624	0.509	499.6	414.7	215.4
SVGA	800	600	0.480	510.8	434.7	223.0
VGA	640	480	0.307	622.7		336.9
HVGA	480	320	0.154	851.8		607.2
QVGA	320	240	0.077	1056.6		
HQVGA	240	160	0.038	1371.3		
QQVGA	160	120	0.019	1572.0		
Max. × half	816	312	0.255	822.8	688.3	363.6
Max. × min.	816	16	0.013	2329.6	2021.0	1164.6
Min. × max.	16	624	0.010	525.4		
Min. × min.	16	16	256 P	3021.2		

¹ RAW8 (GREY) or RGB888 (RGB3) at 12-Bit readout

Table 36: Alvium 1800 C-052m/c ROI frame rates



Maximum frame rates with SensorBitDepth

Alvium 1800 C-052 can run higher frame rates than with ADC bit depth when **SensorBitDepth** is enabled. These values will be added in a future version of this document.



Alvium 1800 C-130 VSWIR

Red table border lines signal that **GenICam for CSI-2 Access** is required.

Feature	Specification
	1800 C-130 VSWIR
Sensor model	Sony IMX990
Resolution	1296 (H) × 1032 (V); 1.3 MP
Sensor type	InGaAs
Shutter type	Global shutter (GS)
Sensor size	Type 1/2; 6.4 mm × 5.12 mm; 8.2 mm diagonal
Pixel size	5 μm × 5 μm
CRA	0 deg
Sensor bit depth (ADC)	8-bit, 10-bit, 12-bit; Adaptive (10-bit, 12-bit)
Sensor bit depth (ADC)	12-bit
	Pixel formats, GenICam for CSI-2 Access
Monochrome pixel formats	Mono8 (default), Mono10, Mono10p, Mono12, Mono12p
	Pixel formats, other access modes
RAW pixel formats	RAW8 (GREY), RAW10 (Y10), RAW12 (Y12)
Maximum frame rate	69 fps, using 1 to 4 lanes
Exposure time	34 μs to 10 s (1 lane)
Exposure modes	Timed, TriggerControlled, TriggerWidth
Gain	0 dB to 42 dB; 0.1 dB increments
Digital binning	Horizontal: 1 to 8 columns; Vertical: 1 to 8 rows
Image buffer (RAM)	256 KByte
Non-volatile memory (Flash)	1024 KByte
GPIOs	2 programmable GPIOs As direct inputs (push-pull): 0 to 5.5 VDC As direct outputs (push-pull): 0 to 3.3 VDC at 12 mA
Power requirements	Power over MIPI CSI-2
Power consumption (typical, at 5 VDC)	1.9 W
Storage temperature	-20 °C to +85 °C ambient temperature

Table 37: Alvium 1800 C-130 VSWIR specifications (sheet 1 of 2)

Feature	Specification			
	1800 C-130 VSWIR			
Operating temperature	Hardware option	Housing	Cooling area ¹	Mainboard ²
	Bare board ³	Not applicable	-20 °C to +85 °C	-20 °C to +85 °C
	Open housing ⁴	-20 °C to +65 °C		
Relative humidity	0% to 80% (non-condensing)			
Digital interface	MIPI CSI-2 D-PHY V1.1; 1, 2, or 4 lanes; maximum 1.051 Gbit/s per lane			
Camera controls	GenICam (GenICam for CSI-2 Access) V4L2 controls (Video4Linux Access), Direct Register Access			

¹ See [Mounting the heat sink](#) on page 236.

² Output by `DeviceTemperature`

³ Ensure that the sensor is operated in the temperature range specified by the manufacturer. For any questions, please visit www.alliedvision.com/en/support.

⁴ Temperature values must be observed for the housing **and** for the cooling area.

Table 37: Alvium 1800 C-130 VSWIR specifications (sheet 2 of 2)

Relative QE

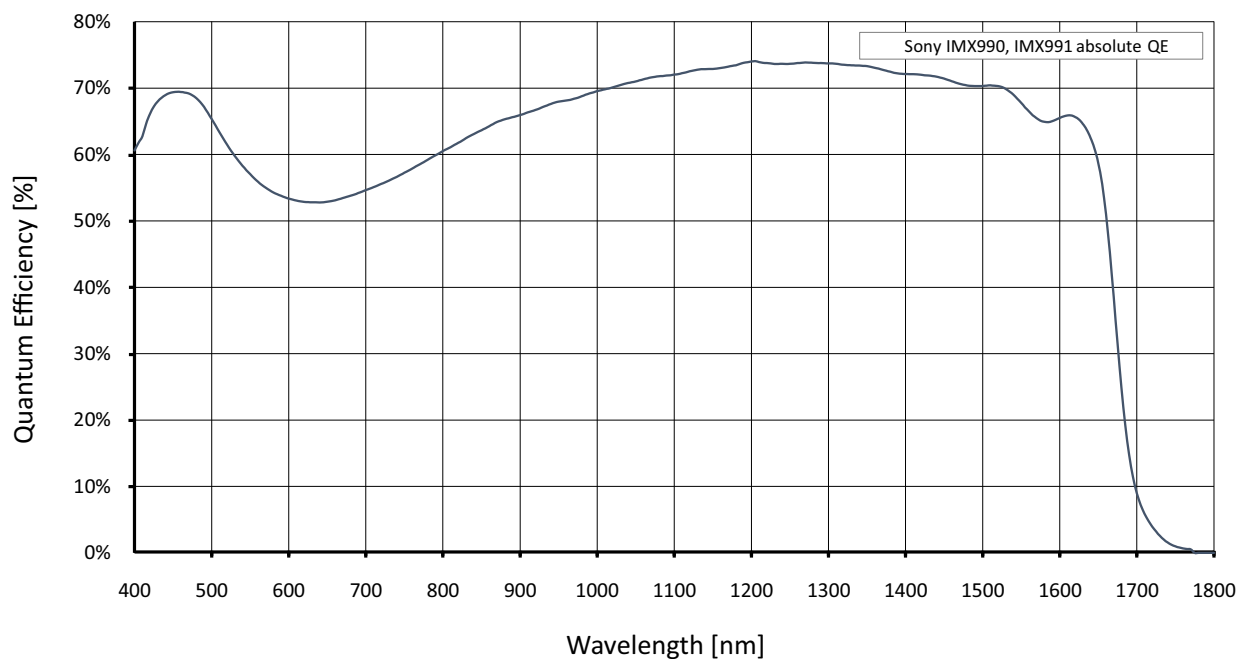

Figure 23: Alvium 1800 C-130 VSWIR (Sony IMX990) relative QE

Frame rates with Cropping

Values were calculated as defined in [Frame rates with ROI/Cropping](#) on page 66 and in [Operation for maximum frame rates](#) on page 68.

Frame rates at maximum bandwidth calculates for 1.051 Gbit/s per lane. To reach the maximum frame rate available for typical operation, the bandwidth for image traffic is at 1 lane with 1.051 Gbit/s. Increasing the CSI-2 Lane Count value does not increase frame rates.

Image format	Width [pixels]	Height [pixels]	ROI area [MP]	Frame rate [fps] ¹		
				4-lane	2-lane	1-lane
				4.204 Gbit/s	2.102 Gbit/s	1.051 Gbit/s
Full resolution	1296	1032	1.337	69.7		
SXGA	1280	1024	1.311	70.3		
HD 720	1280	720	0.922	97.8		
XGA	1024	768	0.786	92.3		
SVGA	800	600	0.480	116.4		
VGA	640	480	0.307	142.9		
HVGA	480	320	0.154	205.1		
QVGA	320	240	0.077	262.7		
HQVGA	240	160	0.038	365.0		
QQVGA	160	120	0.019	454.6		
Max. × half ²	1296	520	0.674	131.8		
Max. × min.	1296	16	0.021	1054.4		
Min. × max.	16	1032	0.017	70.4		
Min. × min.	16	16	256 P	1224.5		

¹ RAW8 (GREY) at 12-Bit readout
² Instead of 1,296 × 516
 If resolutions were not available due to increments, frame rates relate to the next available resolution.

Figure 24: Alvim 1800 C-130 VSWIR ROI frame rates



Maximum frame rates with SensorBitDepth

Alvim 1800 C-130 VSWIR can run higher frame rates than with ADC bit depth when SensorBitDepth is enabled. These values will be added in a future version of this document.



Alvium 1800 C-158m/c

Red table border lines signal that **GenICam for CSI-2 Access** is required.

Feature	Specification	
	1800 C-158m (monochrome)	1800 C-158c (color)
Sensor model	Sony IMX273	
Resolution	1456 (H) × 1088 (V); 1.6 MP	
Sensor type	CMOS	
Shutter type	Global shutter (GS)	
Sensor size	Type 1/2.9; 5 mm × 3.8 mm; 6.3 mm diagonal	
Pixel size	3.45 μm × 3.45 μm	
CRA	0 deg	
Sensor bit depth (ADC)	8-bit, 10-bit, 12-bit; Adaptive (10-bit, 12-bit)	
Sensor bit depth (ADC)	12-bit	
Pixel formats, GenICam for CSI-2 Access		
Monochrome pixel formats	Mono8 (default), Mono10, Mono10p, Mono12, Mono12p	Mono8, Mono10, Mono10p, Mono12, Mono12p
YUV color pixel formats	Not applicable	YCbCr411_8_CbYYCrYY, YCbCr422_8_CbYCrY, YCbCr8_CbYCr
RGB color pixel formats	Not applicable	BGR8, RGB8 (default)
Raw color pixel formats	Not applicable	BayerRG8, BayerRG10, BayerRG10p, BayerRG12, BayerRG12p
Pixel formats, other access modes		
YUV color pixel formats	Not applicable	YUV422 8-bit (UYVY)
RGB color pixel formats	Default: RGB888 (RGB3)	
RAW pixel formats	RAW8 (GREY), RAW10 (Y10), RAW12 (Y12)	
Maximum frame rate	157 fps, using 4 lanes	
Exposure time	26 μs to 10 s (4 lanes)	
Exposure modes	Timed, TriggerControlled, TriggerWidth	
Gain	0 dB to 48 dB; 0.1 dB increments	
Digital binning	Horizontal: 1 to 8 columns; Vertical: 1 to 8 rows	
Sensor binning (H × V)	1 × 2, 2 × 2 (<i>Sum</i>)	Not applicable
Image buffer (RAM)	256 KByte	
Non-volatile memory (Flash)	1024 KByte	
GPIOs	2 programmable GPIOs As direct inputs (push-pull): 0 to 5.5 VDC As direct outputs (push-pull): 0 to 3.3 VDC at 12 mA	
Power requirements	Power over MIPI CSI-2	

Table 38: Alvium 1800 C-158m/c specifications (sheet 1 of 2)

Feature	Specification			
	1800 C-158m/c			
Power consumption (typical, at 5 VDC)	2.4 W			
Storage temperature	-20 °C to +85 °C ambient temperature			
Operating temperature	Hardware option	Housing	Cooling area¹	Mainboard²
	Bare board ³	Not applicable	-20 °C to +85 °C	-20 °C to +85 °C
	Open housing ⁴	-20 °C to +65 °C		
Relative humidity	0% to 80% (non-condensing)			
Digital interface	MIPI CSI-2 D-PHY V1.1; 1, 2, or 4 lanes; maximum 1.051 Gbit/s per lane			
Camera controls	GenICam (GenICam for CSI-2 Access) V4L2 controls (Video4Linux Access), Direct Register Access			
¹ See Mounting the heat sink on page 236. ² Output by <code>DeviceTemperature</code> ³ Ensure that the sensor is operated in the temperature range specified by the manufacturer. For any questions, please visit www.alliedvision.com/en/support . ⁴ Temperature values must be observed for the housing and for the cooling area.				

Table 38: Alvium 1800 C-158m/c specifications (sheet 2 of 2)

Absolute QE

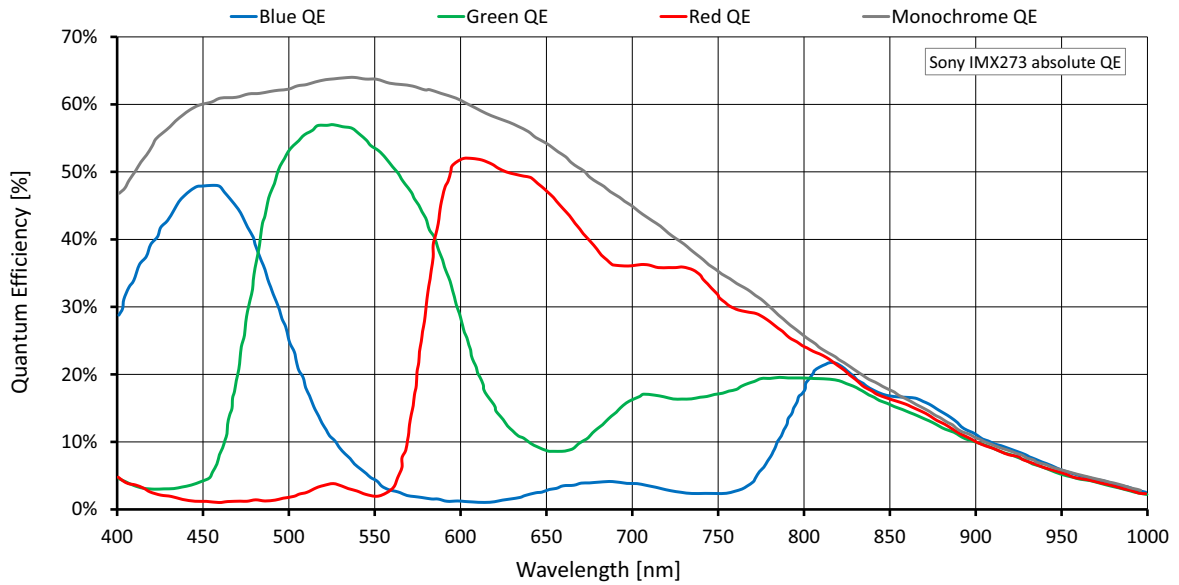

Figure 25: Alvium 1800 C-158m/c (Sony IMX273) absolute QE

Spectral response

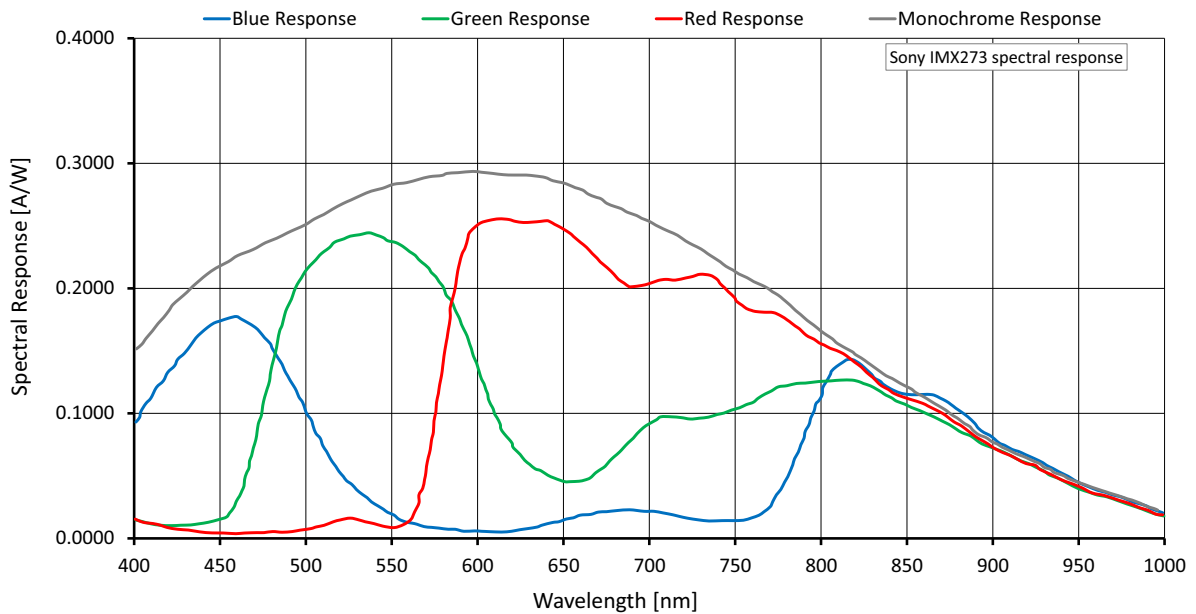

Figure 26: Alvium 1800 C-158m/c (Sony IMX273) spectral response

Frame rates with Cropping

Values were calculated as defined in [Frame rates with ROI/Cropping](#) on page 66 and in [Operation for maximum frame rates](#) on page 68.

Frame rates at maximum bandwidth calculates for 1.051 Gbit/s per lane. To reach the maximum frame rate available for typical operation, the bandwidth for image traffic is at 4 lanes with 4.204 Gbit/s.

Image format	Width [pixels]	Height [pixels]	ROI area [MP]	Frame rate [fps] ¹		
				4-lane	2-lane	1-lane
				4.204 Gbit/s	2.102 Gbit/s	1.051 Gbit/s
Full resolution	1456	1088	1.584	157.4	153.0	77.5
WXGA+ ²	1440	904	1.302	186.7	184.0	93.6
SXGA	1280	1024	1.311	167.1		93.6
HD 720	1280	720	0.922	230.5		129.7
XGA	1024	768	0.786	218.8		152.6
SVGA	800	600	0.480	275.6		243.7
VGA	640	480	0.307	337.6		
HVGA	480	320	0.154	482.2		
QVGA	320	240	0.077	617.7		
HQVGA	240	160	0.038	847.2		
QQVGA	160	120	0.019	1037.6		
Max. × half	1456	544	0.792	293.6	285.5	146.5
Max. × min.	1456	16	0.023	1828.7	1793.4	1067.5
Min. × max.	16	1088	0.017	161.1		
Min. × min.	16	16	256 P	2495.9		

¹ RAW8 (GREY) or RGB888 (RGB3) at 12-Bit readout
² Instead of 1,440 × 900
 If resolutions were not available due to increments, frame rates relate to the next available resolution.

Figure 27: Alvim 1800 C-158m/c ROI frame rates



Maximum frame rates with SensorBitDepth

Alvim 1800 C-158 can run higher frame rates than with ADC bit depth when **SensorBitDepth** is enabled. These values will be added in a future version of this document.



Alvium 1800 C-203m/c

Red table border lines signal that **GenICam for CSI-2 Access** is required.

Feature	Specification	
	1800 C-203m (monochrome)	1800 C-203c (color)
Sensor model	IMX422	
Resolution	1632 (H) × 1248 (V); 2.03 MP	
Sensor type	CMOS	
Shutter type	Global shutter (GS)	
Sensor size	Type 1/1.7; 7.3 mm × 5.6 mm; 9.2 mm diagonal	
Pixel size	4.5 μm × 4.5 μm	
CRA	0° deg	
Sensor bit depth (ADC)	8-bit, 10-bit, 12-bit; Adaptive (10-bit, 12-bit)	
Sensor bit depth (ADC)	12-bit	
Pixel formats, GenICam for CSI-2 Access		
Monochrome pixel formats	Mono8 (default), Mono10, Mono10p, Mono12, Mono12p	Mono8, Mono10, Mono10p, Mono12, Mono12p
YUV color pixel formats	Not applicable	YCbCr411_8_CbYYCrYY, YCbCr422_8_CbYCrY, YCbCr8_CbYCr
RGB color pixel formats	Not applicable	BGR8, RGB8 (default)
Raw color pixel formats	Not applicable	BayerRG8, BayerRG10, BayerRG10p, BayerRG12, BayerRG12p
Pixel formats, other access modes		
YUV color pixel formats	Not applicable	YUV422 8-bit (UYVY)
RGB color pixel formats	Default: RGB888 (RGB3)	
RAW pixel formats	RAW8 (GREY), RAW10 (Y10), RAW12 (Y12)	
Maximum frame rate	225 fps, using 1 to 4 lanes (using SensorBitDepth)	
Maximum frame rate	118 fps, using 4 lanes	
Exposure time	15 μs to 10 s (4 lanes)	
Exposure modes	Timed	
Gain	0 dB to 48 dB; 0.1 dB increments	
Digital binning	Horizontal: 1 to 8 columns; Vertical: 1 to 8 rows	
Sensor binning (H × V)	2 × 2 (<i>Sum, Average</i>)	Not applicable
Image buffer (RAM)	256 KByte	
Non-volatile memory (Flash)	1024 KByte	
GPIOs	2 programmable GPIOs As direct inputs (push-pull): 0 to 5.5 VDC As direct outputs (push-pull): 0 to 3.3 VDC at 12 mA	
Power requirements	Power over MIPI CSI-2	

Table 39: Alvium 1800 C-203m/c specifications (sheet 1 of 2)

Feature	Specification			
	1800 C-203m (monochrome)		1800 C-203c (color)	
Power consumption (typical, at 5 VDC)	3.1 W			
Storage temperature	-20 °C to +85 °C ambient temperature			
Operating temperature	Hardware option	Housing	Cooling area¹	Mainboard²
	Bare board ³	Not applicable	-20 °C to +85 °C	-20 °C to +85 °C
	Open housing ⁴	-20 °C to +65 °C		
Relative humidity	0% to 80% (non-condensing)			
Digital interface	MIPI CSI-2 D-PHY V1.1; 1, 2, or 4 lanes; maximum 1.051 Gbit/s per lane			
Camera controls	GenICam (GenICam for CSI-2 Access)			
	V4L2 controls (Video4Linux Access), Direct Register Access			
¹ See Mounting the heat sink on page 236. ² Output by DeviceTemperature ³ Ensure that the sensor is operated in the temperature range specified by the manufacturer. For any questions, please visit www.alliedvision.com/en/support . ⁴ Temperature values must be observed for the housing and for the cooling area.				

Table 39: Alvium 1800 C-203m/c specifications (sheet 2 of 2)

Absolute QE, spectral response

Diagrams will be added in a future version of this document.

ROI frame rates

Values were calculated as defined in [Frame rates with ROI/Cropping](#) on page 66 and in [Operation for maximum frame rates](#) on page 68.

Frame rates at maximum bandwidth calculates for 1.051 Gbit/s per lane. To reach the maximum frame rate available for typical operation, the bandwidth for image traffic is at 4 lanes with 4.204 Gbit/s.

Image format	Width [pixels]	Height [pixels]	ROI area [MP]	Frame rate [fps] ¹		
				4-lane	2-lane	1-lane
				4.204 Gbit/s	2.102 Gbit/s	1.051 Gbit/s
Full resolution	1632	1248	2.037	225.8 / 118.0 / 118.7	118.8 / 60.0 / 60.1	60.1 / 30.2 / 30.2
UXGA	1600	1200	1.920	234.2 / 125.0 / 124.7	125.3 / 63.5 / 63.5	63.5 / 31.9 / 32.0
WXGA+	1440	904	1.302	303.0 / 179.5 / 180.0	181.3 / 91.6 / 91.5	91.6 / 46.1 / 46.1
SXGA	1280	1024	1.311	272.1 / 180.2 / 179.5	181.5 / 91.8 / 91.8	92.1 / 46.2 / 46.4
HD 720	1280	720	0.922	371.4 / 246.6 / 245.6	248.8 / 126.3 / 126.3	126.8 / 63.7 / 64.0
XGA	1024	768	0.786	354.0 / 288.0 / 245.5	292.6 / 149.0 / 148.7	149.4 / 75.1 / 75.4
SVGA	800	600	0.480	441.3 / 359.6 / 307.0	441.3 / 236.2 / 236.0	236.3 / 120.0 / 120.2
VGA	640	480	0.307	536.2 / 437.0 / 373.7	536.2 / 356.3 / 355.9	358.5 / 181.3 / 182.0
HVGA	480	320	0.154	750.9 / 610.9 / 524.2		665.8 / 336.4 / 338.3
QVGA	320	240	0.077	943.2 / 767.4 / 660.6		943.2 / 625.9 / 630.0
HQVGA	240	160	0.038	1257.6 / 1027.3 / 885.3		
QQVGA	160	120	0.019	1516.5 / 1239.9 / 1077.6		
Max. × half	1632	624	1.018	414.7 / 219.0 / 220.2	221.3 / 112.3 / 112.5	112.7 / 56.8 / 56.9
Max. × min.	1632	16	0.026	2241.8 / 1319.7 / 1317.3	1391.5 / 750.2 / 758.1	765.3 / 402.4 / 410.0
Min. × max.	16	1248	0.020	232.8 / 189.5 / 161.3		
Min. × min.	16	16	256 P	3189.4 / 2621.8 / 2344.6		

¹ Mono8 or Bayer...8⁽²⁾ at **SensorBitDepth** = 8-Bit⁽³⁾ /
 Mono10 or Bayer...10 at **SensorBitDepth** = 10-Bit
 Mono12 or Bayer...12 at **SensorBitDepth** = 12-Bit

² The three dots... represent the colors of a Bayer pixel format, such as in BayerRG8.

³ The **SensorBitDepth** value must be set separately from **PixelFormat**.
 See [Readout modes to reduce the bandwidth](#) on page 67 for details.

¹ Not applicable / RAW8 (GREY) or RGB888 (RGB3) at 12-Bit readout

Table 40: Alvim 1800 C-203m/c ROI frame rates



Alvium 1800 C-234m/c

Red table border lines signal that **GenICam for CSI-2 Access** is required.

Feature	Specification	
	1800 C-234m (monochrome)	1800 C-234c (color)
Sensor model	Sony IMX249	
Resolution	1936 (H) × 1216 (V); 2.35 MP	
Sensor type	CMOS	
Shutter type	Global shutter (GS)	
Sensor size	Type 1/1.2; 11.3 mm × 7.1 mm; 13.4 mm diagonal	
Pixel size	5.86 μm × 5.86 μm	
CRA	0 deg	
Sensor bit depth (ADC)	10-bit, 12-bit; Adaptive (10-bit, 12-bit)	
Sensor bit depth (ADC)	12-bit	
Pixel formats, GenICam for CSI-2 Access		
Monochrome pixel formats	Mono8 (default), Mono10, Mono10p, Mono12, Mono12p	Mono8, Mono10, Mono10p, Mono12, Mono12p
YUV color pixel formats	Not applicable	YCbCr411_8_CbYYCrYY, YCbCr422_8_CbYCrY, YCbCr8_CbYCr
RGB color pixel formats	Not applicable	BGR8, RGB8 (default)
Raw color pixel formats	Not applicable	BayerRG8, BayerRG10, BayerRG10p, BayerRG12, BayerRG12p
Pixel formats, other access modes		
YUV color pixel formats	Not applicable	YUV422 8-bit (UYVY)
RGB color pixel formats	Default: RGB888 (RGB3)	
RAW pixel formats	RAW8 (GREY), RAW10 (Y10), RAW12 (Y12)	
Maximum frame rate	40 fps, using 1 to 4 lanes (using SensorBitDepth)	
Maximum frame rate	31 fps, using 1 to 4 lanes	
Exposure time	64 μs to 10 s (1 lane)	
Exposure modes	Timed	
Gain	0 dB to 48 dB; 0.1 dB increments	
Digital binning	Horizontal: 1 to 8 columns; Vertical: 1 to 8 rows	
Image buffer (RAM)	256 KByte	
Non-volatile memory (Flash)	1024 KByte	
GPIOs	2 programmable GPIOs As direct inputs (push-pull): 0 to 5.5 VDC As direct outputs (push-pull): 0 to 3.3 VDC at 12 mA	
Power requirements	Power over MIPI CSI-2	
Power consumption (typical, at 5 VDC)	1.9 W	

Table 41: Alvium 1800 C-234m/c specifications (sheet 1 of 2)

Feature	Specification			
	1800 C-234m (monochrome)		1800 C-234c (color)	
Storage temperature	-20 °C to +85 °C ambient temperature			
Operating temperature	Hardware option	Housing	Cooling area¹	Mainboard²
	Bare board ³	Not applicable	-20 °C to +85 °C	-20 °C to +85 °C
	Open housing ⁴	-20 °C to +65 °C		
Relative humidity	0% to 80% (non-condensing)			
Digital interface	MIPI CSI-2 D-PHY V1.1; 1, 2, or 4 lanes; maximum 1.051 Gbit/s per lane			
Camera controls	GenICam (GenICam for CSI-2 Access)			
	V4L2 controls (Video4Linux Access), Direct Register Access			
¹ See Mounting the heat sink on page 236. ² Output by <code>DeviceTemperature</code> ³ Ensure that the sensor is operated in the temperature range specified by the manufacturer. For any questions, please visit www.alliedvision.com/en/support . ⁴ Temperature values must be observed for the housing and for the cooling area.				

Table 41: Alvim 1800 C-234m/c specifications (sheet 2 of 2)

Absolute QE

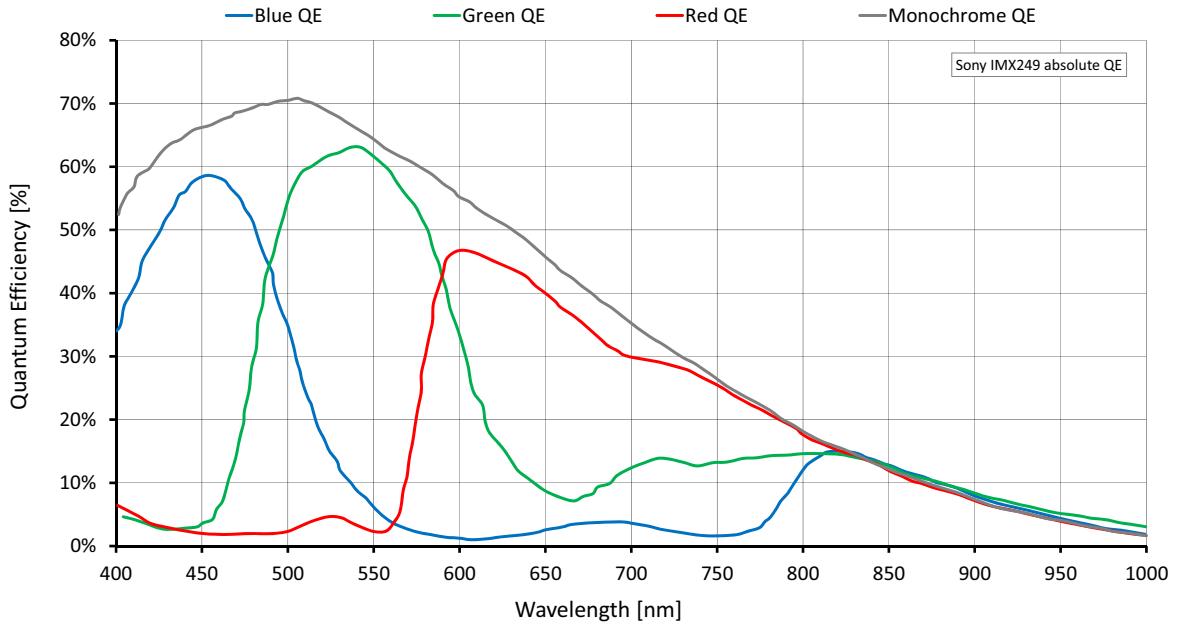

Figure 28: Alvim 1800 C-234m/c (Sony IMX249) absolute QE

Spectral response

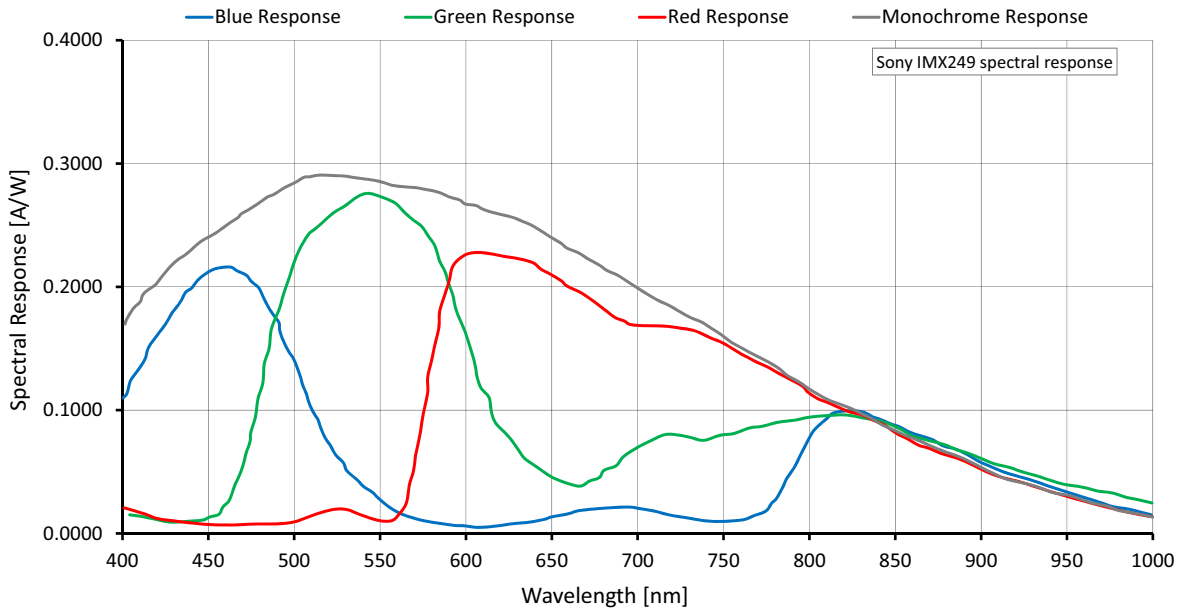

Figure 29: Alvim 1800 C-234m/c (Sony IMX249) spectral response

ROI frame rates

Values were calculated as defined in [Frame rates with ROI/Cropping](#) on page 66 and in [Operation for maximum frame rates](#) on page 68.

Frame rates at maximum bandwidth calculates for 1.051 Gbit/s per lane. To reach the maximum frame rate available for typical operation, the bandwidth for image traffic is at 1 lane with 1.051 Gbit/s. Increasing the CSI-2 Lane Count value does not increase frame rates.

Image format	Width [pixels]	Height [pixels]	ROI area [MP]	Frame rate [fps] ¹		
				4-lane	2-lane	1-lane
				4.204 Gbit/s	2.102 Gbit/s	1.051 Gbit/s
Full resolution	1936	1216	2.354	40.4 / 31.5		40.4 / 26.7
Full HD	1920	1080	2.074	45.3 / 35.3		45.3 / 30.2
UXGA	1600	1200	1.920	41.0 / 31.9		
WXGA+ ⁴	1,440	904	1.302	53.7 / 41.8		
SXGA	1280	1024	1.311	47.7 / 37.2		
HD 720	1280	720	0.922	66.5 / 51.9		
XGA	1024	768	0.786	62.7 / 48.9		
SVGA	800	600	0.480	79.0 / 61.6		
VGA	640	480	0.307	96.9 / 75.5		
HVGA	480	320	0.154	139.2 / 108.5		
QVGA	320	240	0.077	177.8 / 138.5		
HQVGA	240	160	0.038	245.8 / 192.5		
QQVGA	160	120	0.019	305.8 / 238.3		
Max. × half	1936	608	1.177	77.6 / 60.5		77.6 / 51.3
Max. × min.	1936	16	0.031	734.0 / 580.4		734.0 / 498.5
Min. × max.	16	1216	0.019	40.6 / 31.6		
Min. × min.	16	16	256 P	802.8 / 625.7		

¹ Mono8 or Mono10, or Bayer...8 or Bayer...10⁽²⁾ at **SensorBitDepth** = 10-Bit⁽³⁾ / Mono12 or Bayer...12 at **SensorBitDepth** = 12-Bit

² The three dots... represent the colors of a Bayer pixel format, such as in Bayer**RG8**.

³ The **SensorBitDepth** value must be set separately from **PixelFormat**. See [Readout modes to reduce the bandwidth](#) on page 67 for details.

⁴ Instead of 1,440 × 900
If resolutions were not available due to increments, frame rates relate to the next available resolution.

¹ Not applicable / RAW8 (GREY) or RGB888 (RGB3) at 12-Bit readout

⁴ Instead of 1,440 × 900
If resolutions were not available due to increments, frame rates relate to the next available resolution.

Table 42: Alvium 1800 C-234m/c ROI frame rates



Alvium 1800 C-235m/c

Red table border lines signal that **GenICam for CSI-2 Access** is required.

Feature	Specification	
	1800 C-235m (monochrome)	1800 C-235c (color)
Sensor model	Sony IMX174	
Resolution	1936 (H) × 1216 (V); 2.35 MP	
Sensor type	CMOS	
Shutter type	Global shutter (GS)	
Sensor size	Type 1/1.2; 11.3 mm × 7.1 mm; 13.4 mm diagonal	
Pixel size	5.86 μm × 5.86 μm	
CRA	0 deg	
Sensor bit depth (ADC)	10-bit, 12-bit; Adaptive (10-bit, 12-bit)	
Sensor bit depth (ADC)	12-bit	
Pixel formats, GenICam for CSI-2 Access		
Monochrome pixel formats	Mono8 (default), Mono10, Mono10p, Mono12, Mono12p	Mono8, Mono10, Mono10p, Mono12, Mono12p
YUV color pixel formats	Not applicable	YCbCr411_8_CbYYCrYY, YCbCr422_8_CbYCrY, YCbCr8_CbYCr
RGB color pixel formats	Not applicable	BGR8, RGB8 (default)
Raw color pixel formats	Not applicable	BayerRG8, BayerRG10, BayerRG10p, BayerRG12, BayerRG12p
Pixel formats, other access modes		
YUV color pixel formats	Not applicable	YUV422 8-bit (UYVY)
RGB color pixel formats	Default: RGB888 (RGB3)	
RAW pixel formats	RAW8 (GREY), RAW10 (Y10), RAW12 (Y12)	
Maximum frame rate	155 fps, using 1 to 4 lanes (using SensorBitDepth)	
Maximum frame rate	103 fps, using 4 lanes	
Exposure time	27 μs to 10 s (4 lanes)	
Exposure modes	Timed	
Gain	0 dB to 48 dB; 0.1 dB increments	
Digital binning	Horizontal: 1 to 8 columns; Vertical: 1 to 8 rows	
Image buffer (RAM)	256 KByte	
Non-volatile memory (Flash)	1024 KByte	
GPIOs	2 programmable GPIOs As direct inputs (push-pull): 0 to 5.5 VDC As direct outputs (push-pull): 0 to 3.3 VDC at 12 mA	
Power requirements	Power over MIPI CSI-2	
Power consumption (typical, at 5 VDC)	2.6 W	

Table 43: Alvium 1800 C-235m/c specifications (sheet 1 of 2)

Feature	Specification			
	1800 C-235m (monochrome)		1800 C-235c (color)	
Storage temperature	-20 °C to +85 °C ambient temperature			
Operating temperature	Hardware option	Housing	Cooling area¹	Mainboard²
	Bare board ³	Not applicable	-20 °C to +85 °C	-20 °C to +85 °C
	Open housing ⁴	-20 °C to +65 °C		
Relative humidity	0% to 80% (non-condensing)			
Digital interface	MIPI CSI-2 D-PHY V1.1; 1, 2, or 4 lanes; maximum 1.051 Gbit/s per lane			
Camera controls	GenICam (GenICam for CSI-2 Access)			
	V4L2 controls (Video4Linux Access), Direct Register Access			

¹ See [Mounting the heat sink](#) on page 236.

² Output by `DeviceTemperature`

³ Ensure that the sensor is operated in the temperature range specified by the manufacturer. For any questions, please visit www.alliedvision.com/en/support.

⁴ Temperature values must be observed for the housing **and** for the cooling area.

Table 43: Alvim 1800 C-235m/c specifications (sheet 2 of 2)

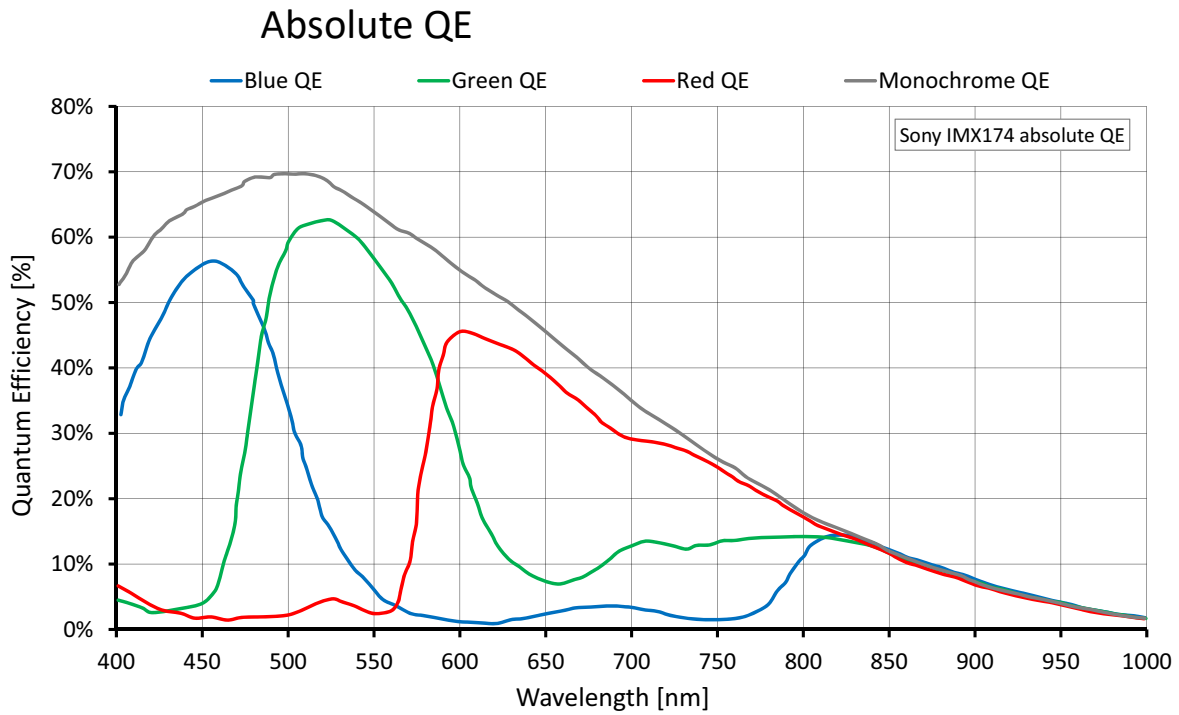

Figure 30: Alvium 1800 C-235m/c (Sony IMX174) absolute QE

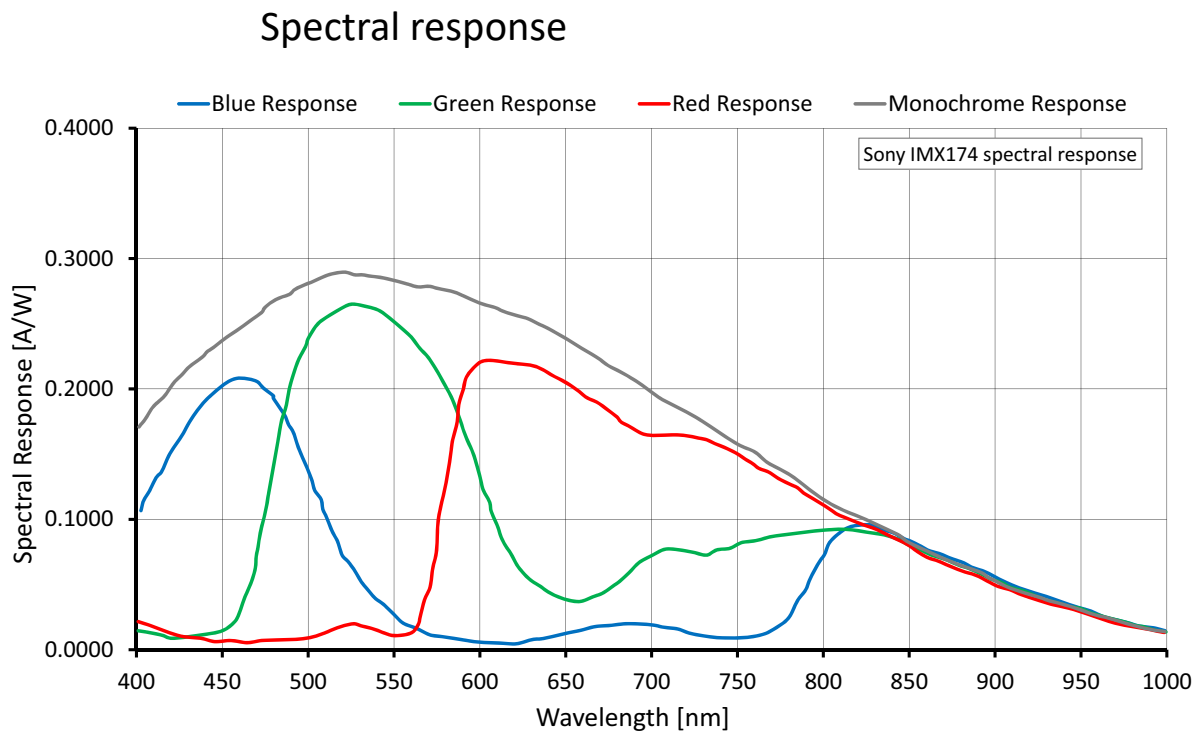

Figure 31: Alvium 1800 C-234m/c (Sony IMX174) spectral response

ROI frame rates

Values were calculated as defined in [Frame rates with ROI/Cropping](#) on page 66 and in [Operation for maximum frame rates](#) on page 68.

Frame rates at maximum bandwidth calculates for 1.051 Gbit/s per lane. To reach the maximum frame rate available for typical operation, the bandwidth for image traffic is at 4 lanes with 4.204 Gbit/s.

Image format	Width [pixels]	Height [pixels]	ROI area [MP]	Frame rate [fps] ¹		
				4-lane	2-lane	1-lane
				4.204 Gbit/s	2.102 Gbit/s	1.051 Gbit/s
Full resolution	1936	1216	2.354	155.8 / 103.7	104.5 / 52.8	53.1 / 26.6
Full HD	1920	1080	2.074	174.1 / 117.2	117.9 / 59.7	59.9 / 30.0
UXGA	1600	1200	1.920	158.6 / 124.0	127.9 / 64.8	65.0 / 32.6
WXGA+ ⁴	1440	904	1.302	207.1 / 161.8	184.9 / 94.0	94.4 / 47.3
SXGA	1280	1024	1.311	185.1 / 144.6	185.1 / 94.0	94.3 / 47.5
HD 720	1280	720	0.922	255.8 / 200.0	255.8 / 130.4	131.1 / 66.1
XGA	1024	768	0.786	242.7 / 189.7	242.7 / 153.3	154.4 / 77.8
SVGA	800	600	0.480	305.9 / 238.9		246.8 / 124.9
VGA	640	480	0.307	376.0 / 293.2		376.0 / 190.8
HVGA	480	320	0.154	538.1 / 420.8		538.1 / 361.6
QVGA	320	240	0.077	689.5 / 539.6		
HQVGA	240	160	0.038	955.0 / 744.8		
QQVGA	160	120	0.019	1189.6 / 927.8		
Max. × half	1936	608	1.177	291.8 / 195.5	197.6 / 100.6	101.3 / 51.0
Max. × min.	1936	16	0.031	1937.3 / 1401.1	1483.5 / 845.2	880.6 / 470.8
Min. × max.	16	1216	0.019	160.6 / 125.3		
Min. × min.	16	16	256 P	3082.2 / 2403.8		

¹ Mono8 or Mono10, or Bayer...8 or Bayer...10⁽²⁾ at **SensorBitDepth** = 10-Bit⁽³⁾ / Mono12 or Bayer...12 at **SensorBitDepth** = 12-Bit

² The three dots... represent the colors of a Bayer pixel format, such as in BayerRG8.

³ The **SensorBitDepth** value must be set separately from **PixelFormat**.
See [Readout modes to reduce the bandwidth](#) on page 67 for details.

⁴ Instead of 1,440 × 900
If resolutions were not available due to increments, frame rates relate to the next available resolution.

¹ Not applicable / RAW8 (GREY) or RGB888 (RGB3) at 12-Bit readout

⁴ Instead of 1,440 × 900
If resolutions were not available due to increments, frame rates relate to the next available resolution.

Table 44: Alvium 1800 C-235m/c ROI frame rates



Alvium 1800 C-240m/c

Red table border lines signal that **GenICam for CSI-2 Access** is required.

Feature	Specification	
	1800 C-240m (monochrome)	1800 C-240c (color)
Sensor model	Sony IMX392	
Resolution	1936 (H) x 1216 (V); 2.4 MP	
Sensor type	CMOS	
Shutter type	Global shutter (GS)	
Sensor size	Type 1/2.3; 6.7 mm x 4.2 mm; 7.9 mm diagonal	
Pixel size	3.45 μm x 3.45 μm	
CRA	0 deg	
Sensor bit depth (ADC)	8-bit, 10-bit, 12-bit; Adaptive (10-bit, 12-bit)	
Sensor bit depth (ADC)	12-bit	
Pixel formats, GenICam for CSI-2 Access		
Monochrome pixel formats	Mono8 (default), Mono10, Mono10p, Mono12, Mono12p	Mono8, Mono10, Mono10p, Mono12, Mono12p
YUV color pixel formats	Not applicable	YCbCr411_8_CbYYCrYY, YCbCr422_8_CbYCrY, YCbCr8_CbYCr
RGB color pixel formats	Not applicable	BGR8, RGB8 (default)
Raw color pixel formats	Not applicable	BayerRG8, BayerRG10, BayerRG10p, BayerRG12, BayerRG12p
Pixel formats, other access modes		
YUV color pixel formats	Not applicable	YUV422 8-bit (UYVY)
RGB color pixel formats	Default: RGB888 (RGB3)	
RAW pixel formats	RAW8 (GREY), RAW10 (Y10), RAW12 (Y12)	
Maximum frame rate	128 fps, using 4 lanes	
Exposure time	26 μs to 10 s (4 lanes)	
Exposure modes	Timed, TriggerControlled, TriggerWidth	
Gain	0 dB to 48 dB; 0.1 dB increments	
Digital binning	Horizontal: 1 to 8 columns; Vertical: 1 to 8 rows	
Sensor binning (H x V)	2 x 2 (<i>Sum</i>)	Not applicable
Image buffer (RAM)	256 KByte	
Non-volatile memory (Flash)	1024 KByte	
GPIOs	2 programmable GPIOs As direct inputs (push-pull): 0 to 5.5 VDC As direct outputs (push-pull): 0 to 3.3 VDC at 12 mA	

Table 45: Alvium 1800 C-240m/c specifications (sheet 1 of 2)

Feature	Specification			
	1800 C-240m/c			
Power requirements	Power over MIPI CSI-2			
Power consumption (typical, at 5 VDC)	2.7 W			
Storage temperature	-20 °C to +85 °C ambient temperature			
Operating temperature	Hardware option	Housing	Cooling area¹	Mainboard²
	Bare board ³	Not applicable	-20 °C to +85 °C	-20 °C to +85 °C
	Open housing ⁴	-20 °C to +65 °C		
Relative humidity	0% to 80% (non-condensing)			
Digital interface	MIPI CSI-2 D-PHY V1.1; 1, 2, or 4 lanes; maximum 1.051 Gbit/s per lane			
Camera controls	GenICam (GenICam for CSI-2 Access)			
	V4L2 controls (Video4Linux Access), Direct Register Access			
¹ See Mounting the heat sink on page 236. ² Output by <code>DeviceTemperature</code> ³ Ensure that the sensor is operated in the temperature range specified by the manufacturer. For any questions, please visit www.alliedvision.com/en/support . ⁴ Temperature values must be observed for the housing and for the cooling area.				

Table 45: Alvium 1800 C-240m/c specifications (sheet 2 of 2)

Absolute QE

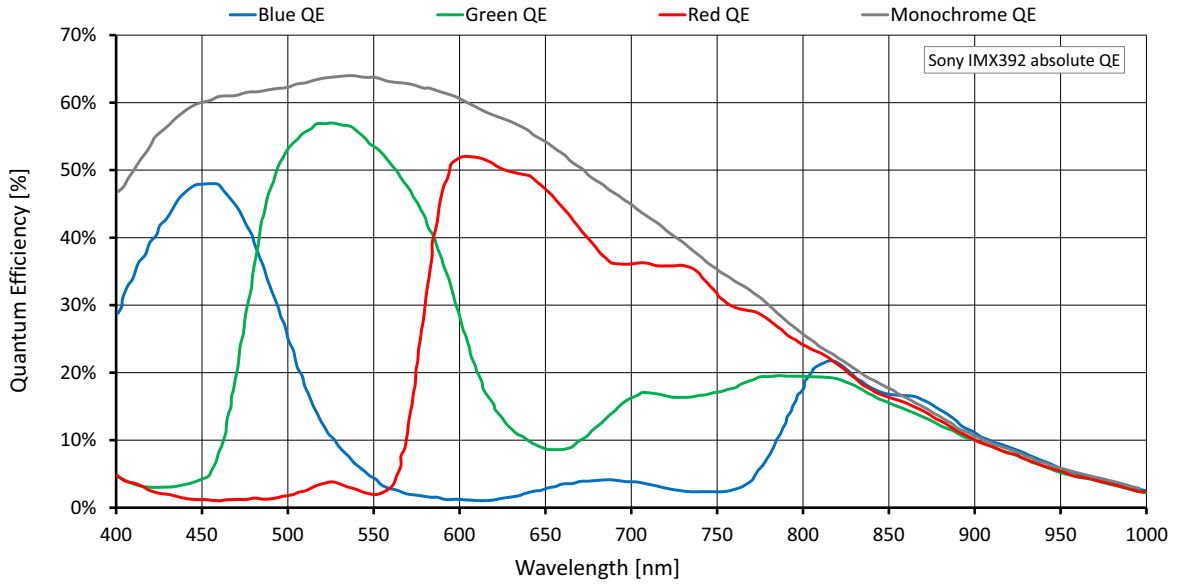

Figure 32: Alvium 1800 C-240m/c (Sony IMX392) absolute QE

Spectral response

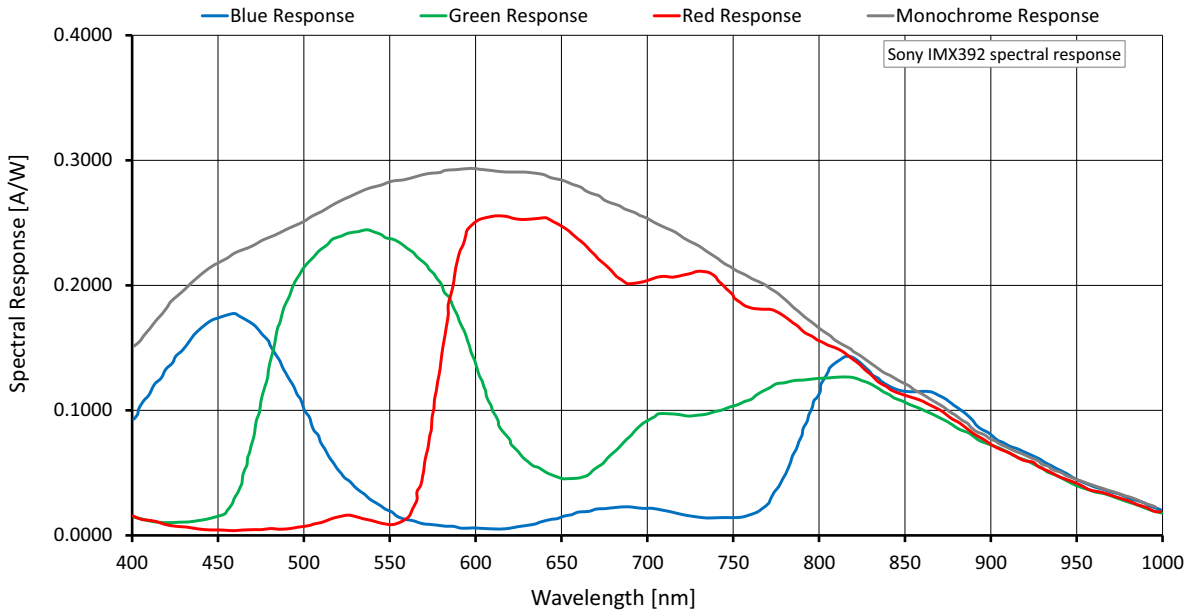

Figure 33: Alvium 1800 C-240m/c (Sony IMX392) spectral response

Frame rates with Cropping

Values were calculated as defined in [Frame rates with ROI/Cropping](#) on page 66 and in [Operation for maximum frame rates](#) on page 68.

Frame rates at maximum bandwidth calculates for 1.051 Gbit/s per lane. To reach the maximum frame rate available for typical operation, the bandwidth for image traffic is at 4 lanes with 4.204 Gbit/s.

Image format	Width [pixels]	Height [pixels]	ROI area [MP]	Frame rate [fps] ¹		
				4-lane	2-lane	1-lane
				4.204 Gbit/s	2.102 Gbit/s	1.051 Gbit/s
Full resolution	1936	1216	2.354	128.6	104.1	53.0
Full HD	1920	1080	2.074	143.6	117.6	59.9
UXGA	1600	1200	1.920	130.9	127.6	65.0
WXGA+ ²	1440	904	1.302	170.9		94.3
SXGA	1280	1024	1.311	152.7		94.3
HD 720	1280	720	0.922	211.4		131.1
XGA	1024	768	0.786	200.7		154.0
SVGA	800	600	0.480	253.0		246.7
VGA	640	480	0.307	311.4		
HVGA	480	320	0.154	447.1		
QVGA	320	240	0.077	574.6		
HQVGA	240	160	0.038	800.1		
QQVGA	160	120	0.019	989.5		
Max. × half	1936	608	1.177	241.6	196.6	101.2
Max. × min.	1936	16	0.031	1672.3	1462.0	889.7
Min. × max.	16	1216	0.019	132.2		
Min. × min.	16	16	256 P	2572.7		

¹ RAW8 (GREY) or RGB888 (RGB3) at 12-Bit readout
² Instead of 1,440 × 900
 If resolutions were not available due to increments, frame rates relate to the next available resolution.

Table 46: Alvium 1800 C-240m/c ROI frame rates



Maximum frame rates with SensorBitDepth

Alvium 1800 C-240 can run higher frame rates than with ADC bit depth when **SensorBitDepth** is enabled. These values will be added in a future version of this document.



Alvium 1800 C-291m/c

Red table border lines signal that **GenICam for CSI-2 Access** is required.

Feature	Specification	
	1800 C-291m (monochrome)	1800 C-291c (color)
Sensor model	Sony IMX421	
Resolution	1944 (H) x 1472 (V); 2.9 MP	
Sensor type	CMOS	
Shutter type	Global shutter (GS)	
Sensor size	Type 2/3; 8.8 mm x 6.6 mm; 10.8 mm diagonal	
Pixel size	4.5 μm x 4.5 μm	
CRA	0 deg	
Sensor bit depth (ADC)	8-bit, 10-bit, 12-bit; Adaptive (10-bit, 12-bit)	
Sensor bit depth (ADC)	12-bit	
Pixel formats, GenICam for CSI-2 Access		
Monochrome pixel formats	Mono8 (default), Mono10, Mono10p, Mono12, Mono12p	Mono8, Mono10, Mono10p, Mono12, Mono12p
YUV color pixel formats	Not applicable	YCbCr411_8_CbYYCrYY, YCbCr422_8_CbYCrY, YCbCr8_CbYCr
RGB color pixel formats	Not applicable	BGR8, RGB8 (default)
Raw color pixel formats	Not applicable	BayerRG8, BayerRG10, BayerRG10p, BayerRG12, BayerRG12p
Pixel formats, other access modes		
YUV color pixel formats	Not applicable	YUV422 8-bit (UYVY)
RGB color pixel formats	Default: RGB888 (RGB3)	
RAW pixel formats	RAW8 (GREY), RAW10 (Y10), RAW12 (Y12)	
Maximum frame rate	116 fps, using 4 lanes	
Exposure time	16 μs to 10 s (4 lanes)	
Exposure modes	Timed, TriggerControlled, TriggerWidth	
Gain	0 dB to 48 dB; 0.1 dB increments	
Digital binning	Horizontal: 1 to 8 columns; Vertical: 1 to 8 rows	
Sensor binning (H x V)	2 x 2 (<i>Sum, Average</i>)	Not applicable
Image buffer (RAM)	256 KByte	
Non-volatile memory (Flash)	1024 KByte	
GPIOs	2 programmable GPIOs As direct inputs (push-pull): 0 to 5.5 VDC As direct outputs (push-pull): 0 to 3.3 VDC at 12 mA	

Table 47: Alvium 1800 C-291m/c specifications (sheet 1 of 2)

Feature	Specification			
	1800 C-291m/c			
Power requirements	Power over MIPI CSI-2			
Power consumption (typical, at 5 VDC)	3.8 W			
Storage temperature	-20 °C to +85 °C ambient temperature			
Operating temperature	Hardware option	Housing	Cooling area¹	Mainboard²
	Bare board ³	Not applicable	-20 °C to +85 °C	-20 °C to +85 °C
	Open housing ⁴	-20 °C to +65 °C		
Relative humidity	0% to 80% (non-condensing)			
Digital interface	MIPI CSI-2 D-PHY V1.1; 1, 2, or 4 lanes; maximum 1.051 Gbit/s per lane			
Camera controls	GenICam (GenICam for CSI-2 Access)			
	V4L2 controls (Video4Linux Access), Direct Register Access			
¹ See Mounting the heat sink on page 236. ² Output by DeviceTemperature ³ Ensure that the sensor is operated in the temperature range specified by the manufacturer. For any questions, please visit www.alliedvision.com/en/support . ⁴ Temperature values must be observed for the housing and for the cooling area.				

Table 47: Alvium 1800 C-291m/c specifications (sheet 2 of 2)

Absolute QE, spectral response

Diagrams will be added in a future version of this document.

Frame rates with Cropping

Values were calculated as defined in [Frame rates with ROI/Cropping](#) on page 66 and in [Operation for maximum frame rates](#) on page 68.

Frame rates at maximum bandwidth calculates for 1.051 Gbit/s per lane. To reach the maximum frame rate available for typical operation, the bandwidth for image traffic is at 4 lanes with 4.204 Gbit/s.

Image format	Width [pixels]	Height [pixels]	ROI area [MP]	Frame rate [fps] ¹		
				4-lane	2-lane	1-lane
				4.204 Gbit/s	2.102 Gbit/s	1.051 Gbit/s
Full resolution	1944	1472	2.862	116.3	85.4	43.1
Full HD	1920	1080	2.074	154.6	115.0	58.6
UXGA	1600	1200	1.920	141.3	125.0	63.7
WXGA+ ²	1440	904	1.302	183.4	180.7	91.9
SXGA	1280	1024	1.311	164.4		92.1
HD 720	1280	720	0.922	225.5		126.8
XGA	1024	768	0.786	214.2		149.3
SVGA	800	600	0.480	268.4		237.3
VGA	640	480	0.307	326.9		
HVGA	480	320	0.154	460.6		
QVGA	320	240	0.077	582.6		
HQVGA	240	160	0.038	782.6		
QQVGA	160	120	0.019	952.0		
Max. × half	1944	736	1.431	217.0	160.5	81.8
Max. × min.	1944	16	0.031	1409.9	1139.9	659.3
Min. × max.	16	1472	0.024	119.7		
Min. × min.	16	16	64 P	2147.6		

¹ RAW8 (GREY) or RGB888 (RGB3) at 12-Bit readout
² Instead of 1,440 × 900
 If resolutions were not available due to increments, frame rates relate to the next available resolution.

Table 48: Alvium 1800 C-291m/c ROI frame rates



Maximum frame rates with SensorBitDepth

Alvium 1800 C-291 can run higher frame rates than with ADC bit depth when **SensorBitDepth** is enabled. These values will be added in a future version of this document.



Alvium 1800 C-319m/c

Red table border lines signal that **GenICam for CSI-2 Access** is required.

Feature	Specification	
	1800 C-319m (monochrome)	1800 C-319c (color)
Sensor model	Sony IMX265	
Resolution	2064 (H) × 1544 (V); 3.2 MP	
Sensor type	CMOS	
Shutter type	Global shutter (GS)	
Sensor size	Type 1/1.8; 7.1 mm × 5.3 mm; 8.9 mm diagonal	
Pixel size	3.45 μm × 3.45 μm	
CRA	0 deg	
Sensor bit depth (ADC)	12-bit	
Pixel formats, GenICam for CSI-2 Access		
Monochrome pixel formats	Mono8 (default), Mono10, Mono10p, Mono12, Mono12p	Mono8, Mono10, Mono10p, Mono12, Mono12p
YUV color pixel formats	Not applicable	YCbCr411_8_CbYYCrYY, YCbCr422_8_CbYCrY, YCbCr8_CbYCr
RGB color pixel formats	Not applicable	BGR8, RGB8 (default)
Raw color pixel formats	Not applicable	BayerRG8, BayerRG10, BayerRG10p, BayerRG12, BayerRG12p
Pixel formats, other access modes		
YUV color pixel formats	Not applicable	YUV422 8-bit (UYVY)
RGB color pixel formats	Default: RGB888 (RGB3)	
RAW pixel formats	RAW8 (GREY), RAW10 (Y10), RAW12 (Y12)	
Maximum frame rate	54 fps, using 2 to 4 lanes	
Exposure time	37 μs to 10 s (2 lanes)	
Exposure modes	Timed, TriggerControlled, TriggerWidth	
Gain	0 dB to 48 dB; 0.1 dB increments	
Digital binning	Horizontal: 1 to 8 columns; Vertical: 1 to 8 rows	
Image buffer (RAM)	256 KByte	
Non-volatile memory (Flash)	1024 KByte	
GPIOs	2 programmable GPIOs As direct inputs (push-pull): 0 to 5.5 VDC As direct outputs (push-pull): 0 to 3.3 VDC at 12 mA	
Power requirements	Power over MIPI CSI-2	
Power consumption (typical, at 5 VDC)	1.9 W	

Table 49: Alvium 1800 C-319m/c specifications (sheet 1 of 2)

Feature	Specification			
	1800 C-319m/c			
Storage temperature	-20 °C to +85 °C ambient temperature			
Operating temperature	Hardware option	Housing	Cooling area¹	Mainboard²
	Bare board ³	Not applicable	-20 °C to +85 °C	-20 °C to +85 °C
	Open housing ⁴	-20 °C to +65 °C		
Relative humidity	0% to 80% (non-condensing)			
Digital interface	MIPI CSI-2 D-PHY V1.1; 1, 2, or 4 lanes; maximum 1.051 Gbit/s per lane			
Camera controls	GenICam (GenICam for CSI-2 Access)			
	V4L2 controls (Video4Linux Access), Direct Register Access			
¹ See Mounting the heat sink on page 236. ² Output by <code>DeviceTemperature</code> ³ Ensure that the sensor is operated in the temperature range specified by the manufacturer. For any questions, please visit www.alliedvision.com/en/support . ⁴ Temperature values must be observed for the housing and for the cooling area.				

Table 49: Alvim 1800 C-319m/c specifications (sheet 2 of 2)

Absolute QE

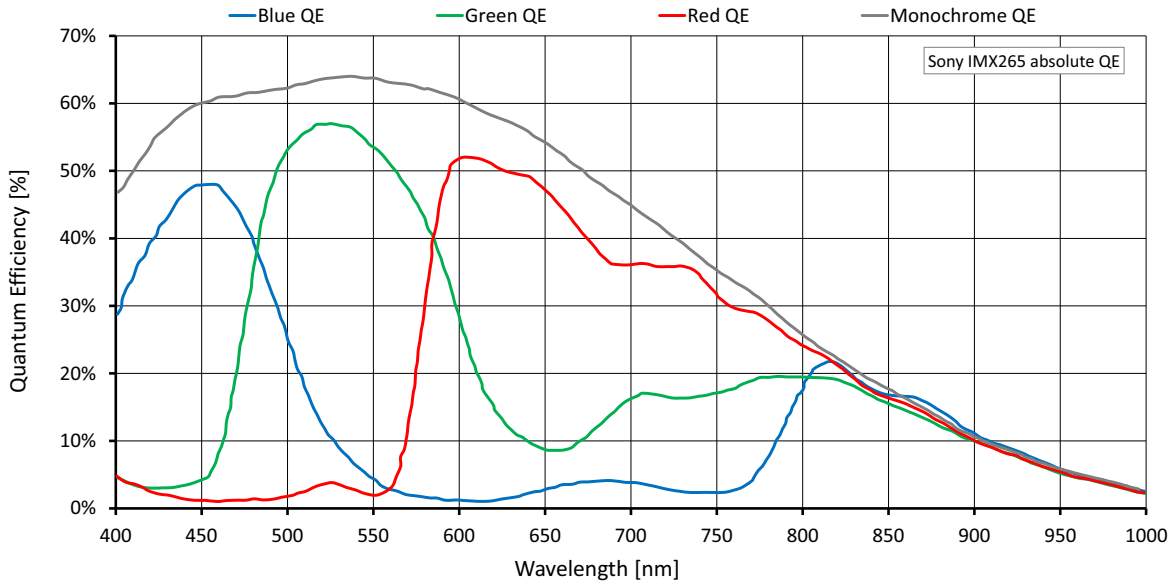

Figure 34: Alvium 1800 C-319m/c (Sony IMX265) absolute QE

Spectral response

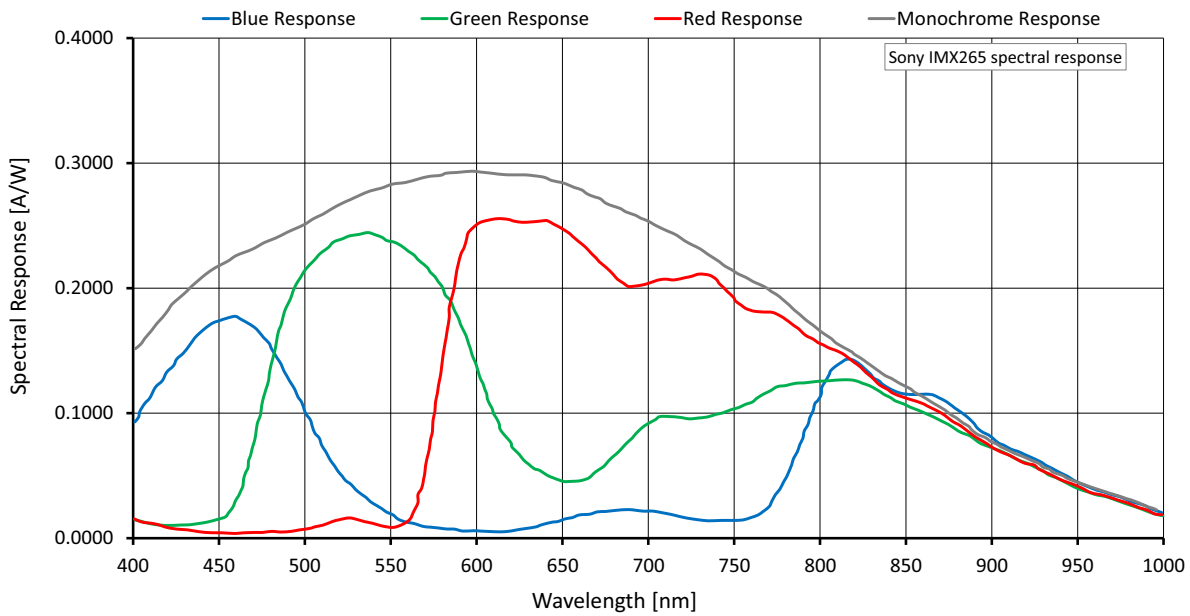

Figure 35: Alvium 1800 C-319m/c (Sony IMX265) spectral response

Frame rates with Cropping

Values were calculated as defined in [Frame rates with ROI/Cropping](#) on page 66 and in [Operation for maximum frame rates](#) on page 68.

Frame rates at maximum bandwidth calculates for 1.051 Gbit/s per lane. To reach the maximum frame rate available for typical operation, the bandwidth for image traffic is at 2 lanes with 2.102 Gbit/s. Increasing the CSI-2 Lane Count value does not increase frame rates.

Image format	Width [pixels]	Height [pixels]	ROI area [MP]	Frame rate [fps] ¹		
				4-lane	2-lane	1-lane
				4.204 Gbit/s	2.102 Gbit/s	1.051 Gbit/s
Full resolution	2064	1544	3.187	54.1		39.5
QXGA	2048	1536	3.146	54.4		40.1
Full HD	1920	1080	2.074	76.1		59.9
UXGA	1600	1200	1.920	69.1		65.0
WXGA+ ²	1440	904	1.302	90.5		
SXGA	1280	1024	1.311	80.5		
HD 720	1280	720	0.922	112.0		
XGA	1024	768	0.786	105.8		
SVGA	800	600	0.480	133.4		
VGA	640	480	0.307	163.8		
HVGA	480	320	0.154	235.5		
QVGA	320	240	0.077	301.5		
HQVGA	240	160	0.038	418.9		
QQVGA	160	120	0.019	518.7		
Max. × half ³	2064	776	1.602	103.6		75.9
Max. × min.	2064	16	0.033	1075.9		835.0
Min. × max.	16	1544	0.025	54.7		
Min. × min.	16	16	256 P	1361.6		

¹ RAW8 (GREY) or RGB888 (RGB3) at 12-Bit readout
² Instead of 1,440 × 900
³ Instead of 2,064 × 772
 If resolutions were not available due to increments, frame rates relate to the next available resolution.

Table 50: Alvium 1800 C-319m/c ROI frame rates



Alvium 1800 C-500m/c

Red table border lines signal that **GeniCam for CSI-2 Access** is required.

Feature	Specification	
	1800 C-500m (monochrome)	1800 C-500c (color)
Sensor model	ON Semiconductor AR0521SR	
Resolution	2592 (H) × 1944 (V); 5.0 MP	
Sensor type	CMOS	
Shutter type	Rolling shutter (RS)	
Sensor size	Type 1/2.5; 5.7 mm × 4.3 mm; 7.1 mm diagonal	
Pixel size	2.2 μm × 2.2 μm	
CRA	9 deg	
Sensor bit depth (ADC)	10-bit	
Pixel formats, GeniCam for CSI-2 Access		
Monochrome pixel formats	Mono8 (default), Mono10, Mono10p, Mono12, Mono12p	Mono8, Mono10, Mono10p, Mono12, Mono12p
YUV color pixel formats	Not applicable	YCbCr411_8_CbYYCrYY, YCbCr422_8_CbYCrY, YCbCr8_CbYCr
RGB color pixel formats		BGR8, RGB8 (default)
Raw color pixel formats	Not applicable	BayerGR8, BayerGR10, BayerGR10p, BayerGR12, BayerGR12p
Pixel formats, other access formats		
YUV color pixel formats	Not applicable	YUV422 8-bit (UYVY)
RGB color pixel formats	Default: RGB888 (RGB3)	
RAW pixel formats	RAW8 (GREY), RAW10 (Y10)	
Maximum frame rate	68 fps ¹ , using 4 lanes	
Exposure time	14 μs to 0.8 s (4 lanes)	
Exposure modes	Timed	
Gain	0 dB to 24 dB; 0.1 dB increments	
Digital binning	Horizontal: 1 to 8 columns; Vertical: 1 to 8 rows	
Sensor binning (H × V)	2 × 1, 4 × 1 (<i>Sum</i>)	
Image buffer (RAM)	256 KByte	
Non-volatile memory (Flash)	1024 KByte	
GPIOs	2 programmable GPIOs As direct inputs (push-pull): 0 to 5.5 VDC As direct outputs (push-pull): 0 to 3.3 VDC at 12 mA	
¹ In triggered mode: ~34 fps		

Table 51: Alvium 1800 C-500m/c specifications (sheet 1 of 2)

Feature	Specification			
	1800 C-500m/c			
Power requirements	Power over MIPI CSI-2			
Power consumption (typical, at 5 VDC)	1.9 W			
Storage temperature	-20 °C to +85 °C ambient temperature			
Operating temperature	Hardware option	Housing	Cooling area²	Mainboard³
	Bare board ⁴	Not applicable	-20 °C to +85 °C	-20 °C to +85 °C
	Open housing ⁵	-20 °C to +65 °C		
Relative humidity	0% to 80% (non-condensing)			
Digital interface	MIPI CSI-2 D-PHY V1.1; 1, 2, or 4 lanes; maximum 1.051 Gbit/s per lane			
Camera controls	GenICam (GenICam for CSI-2 Access)			
	V4L2 controls (Video4Linux Access), Direct Register Access			
² See Mounting the heat sink on page 236.				
³ Output by <code>DeviceTemperature</code>				
⁴ Ensure that the sensor is operated in the temperature range specified by the manufacturer. For any questions, please visit www.alliedvision.com/en/support .				
⁵ Temperature values must be observed for the housing and for the cooling area.				

Table 51: Alvium 1800 C-500m/c specifications (sheet 2 of 2)

Absolute QE

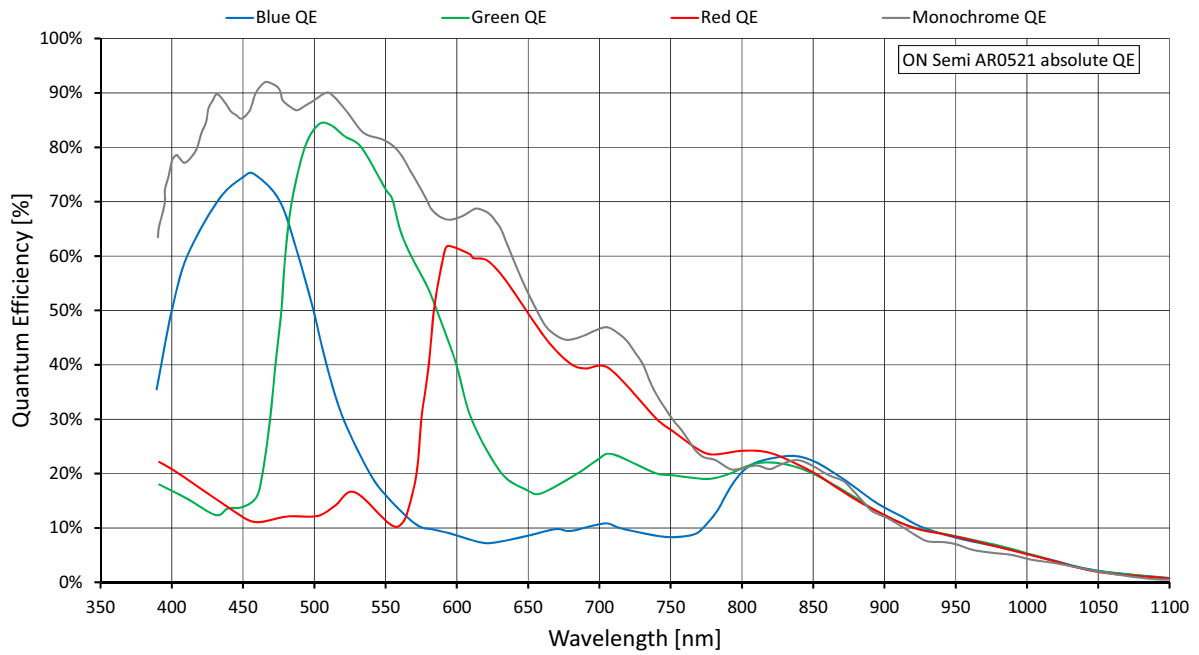

Figure 36: Alvim 1800 C-500m/c (ON Semi AR0521SR) absolute QE

Spectral response

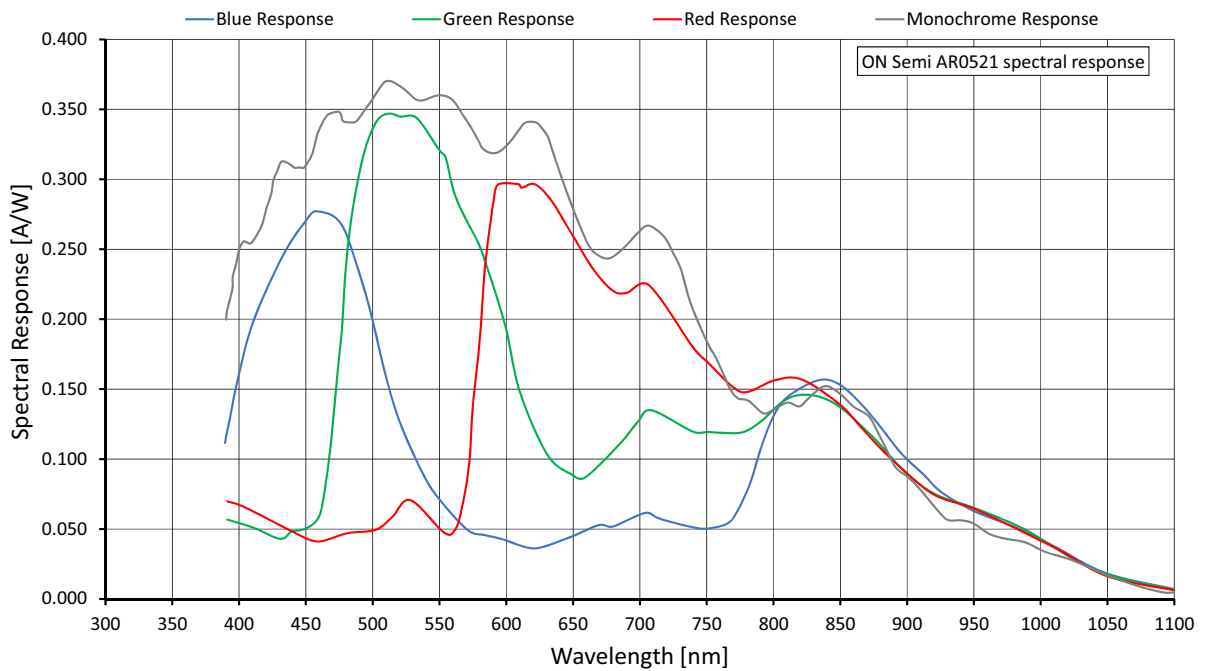

Figure 37: Alvim 1800 C-500m/c (ON Semi AR0521SR) spectral response

Frame rates with Cropping

Values were calculated as defined in [Frame rates with ROI/Cropping](#) on page 66 and in [Operation for maximum frame rates](#) on page 68.

Frame rates at maximum bandwidth calculates for 1.051 Gbit/s per lane. To reach the maximum frame rate available for typical operation, the bandwidth for image traffic is at 4 lanes with 4.204 Gbit/s.

Shutter mode	User mode	Available frame rates
Rolling shutter (RS)	Freerun	Values in Table 53 below are reached.
Rolling shutter (RS)	Triggered	>50% of the values for in Table 53 below are reached.

Table 52: Frame rate behavior for different configurations

Image format	Width [pixels]	Height [pixels]	ROI area [MP]	Frame rate [fps] ¹		
				4-lane	2-lane	1-lane
				4.204 Gbit/s	2.102 Gbit/s	1.051 Gbit/s
Full resolution	2592	1944	5.039	68.1	50.8	25.5
WQHD	2560	1440	3.686	91.1	68.9	34.6
QXGA	2048	1536	3.146	85.8	80.8	40.6
Full HD	1920	1080	2.074	120.5		60.9
UXGA	1600	1200	1.920	109.1		66.0
WXGA+ ²	1440	904	1.302	143.2		96.3
SXGA	1280	1024	1.311	127.2		96.2
HD 720	1280	720	0.922	177.7		134.5
XGA	1024	768	0.786	167.7		158.1
SVGA	800	600	0.480	212.1		
VGA	640	480	0.307	261.3		
HVGA	480	320	0.154	378.2		
QVGA	320	240	0.077	488.0		
HQVGA	240	160	0.038	684.2		
QQVGA	160	120	0.019	856.3		
Max. × half ³	2592	976	2.530	132.0	98.8	49.7
Max. × min.	2592	16	0.041	1917.2	1535.3	858.9
Min. × max.	16	1944	0.031	68.6		
Min. × min.	16	16	256 P	2474.6		

¹ Mono8 / RAW8 (GREY) or Bayer...8⁽²⁾ / RGB888 (RGB3) at 10-Bit readout

² The three dots... represent the colors of a Bayer pixel format, such as in BayerRG8.

³ Instead of 1,440 × 900

⁴ Instead of 2,592 × 972

If resolutions were not available due to increments, frame rates relate to the next available resolution.

Table 53: Alvim 1800 C-500m/c ROI frame rates



Alvium 1800 C-507m/c

Red table border lines signal that **GenICam for CSI-2 Access** is required.

Feature	Specification	
	1800 C-507m (monochrome)	1800 C-507c (color)
Sensor model	Sony IMX264	
Resolution	2464 (H) × 2056 (V); 5.1 MP	
Sensor type	CMOS	
Shutter type	Global shutter (GS)	
Sensor size	Type 2/3; 8.5 mm × 7.1 mm; 11.1 mm diagonal	
Pixel size	3.45 μm × 3.45 μm	
CRA	0 deg	
ADC bit depth	12-bit	
Pixel formats, GenICam for CSI-2 Access		
Monochrome pixel formats	Mono8 (default), Mono10, Mono10p, Mono12, Mono12p	Mono8, Mono10, Mono10p, Mono12, Mono12p
YUV color pixel formats	Not applicable	YCbCr411_8_CbYYCrYY, YCbCr422_8_CbYCrY, YCbCr8_CbYCr
RGB color pixel formats	Not applicable	BGR8, RGB8 (default)
Raw color pixel formats	Not applicable	BayerRG8, BayerRG10, BayerRG10p, BayerRG12, BayerRG12p
Pixel formats, other access modes		
YUV color pixel formats	Not applicable	YUV422 8-bit (UYVY)
RGB color pixel formats	Default: RGB888 (RGB3)	
RAW pixel formats	RAW8 (GREY), RAW10 (Y10), RAW12 (Y12)	
Maximum frame rate	34 fps, using 2 to 4 lanes	
Exposure time	41 μs to 10 s (2 lanes)	
Exposure modes	Timed, TriggerControlled, TriggerWidth	
Gain	0 dB to 48 dB; 0.1 dB increments	
Digital binning	Horizontal: 1 to 8 columns; Vertical: 1 to 8 rows	
Image buffer (RAM)	256 KByte	
Non-volatile memory (Flash)	1024 KByte	
GPIOs	2 programmable GPIOs As direct inputs (push-pull): 0 to 5.5 VDC As direct outputs (push-pull): 0 to 3.3 VDC at 12 mA	
Power requirements	Power over MIPI CSI-2	

Table 54: Alvium 1800 C-507m/c specifications (sheet 1 of 2)

Feature	Specification			
	1800 C-507m/c			
Power consumption (typical, at 5 VDC)	1.9 W			
Storage temperature	-20 °C to +85 °C ambient temperature			
Operating temperature	Hardware option	Housing	Cooling area¹	Mainboard²
	Bare board ³	Not applicable	-20 °C to +85 °C	-20 °C to +85 °C
	Open housing ⁴	-20 °C to +65 °C		
Relative humidity	0% to 80% (non-condensing)			
Digital interface	MIPI CSI-2 D-PHY V1.1; 1, 2, or 4 lanes; maximum 1.051 Gbit/s per lane			
Camera controls	GenICam (GenICam for CSI-2 Access) V4L2 controls (Video4Linux Access), Direct Register Access			
¹ See Mounting the heat sink on page 236. ² Output by <code>DeviceTemperature</code> ³ Ensure that the sensor is operated in the temperature range specified by the manufacturer. For any questions, please visit www.alliedvision.com/en/support . ⁴ Temperature values must be observed for the housing and for the cooling area.				

Table 54: Alvium 1800 C-507m/c specifications (sheet 2 of 2)

Absolute QE

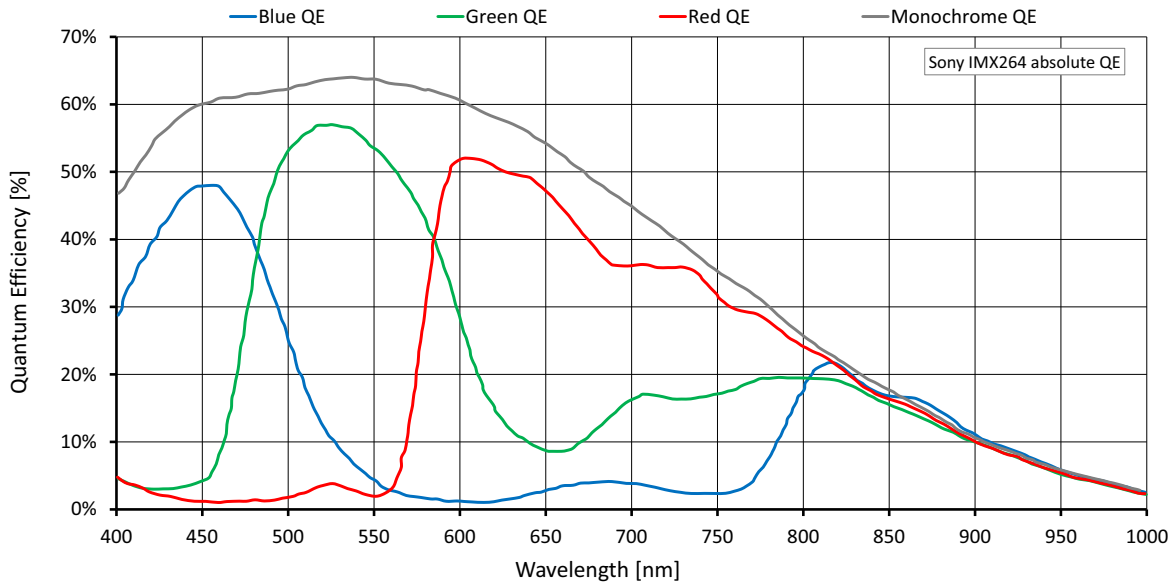

Figure 38: Alvium 1800 C-507m/c (Sony IMX264) absolute QE

Spectral response

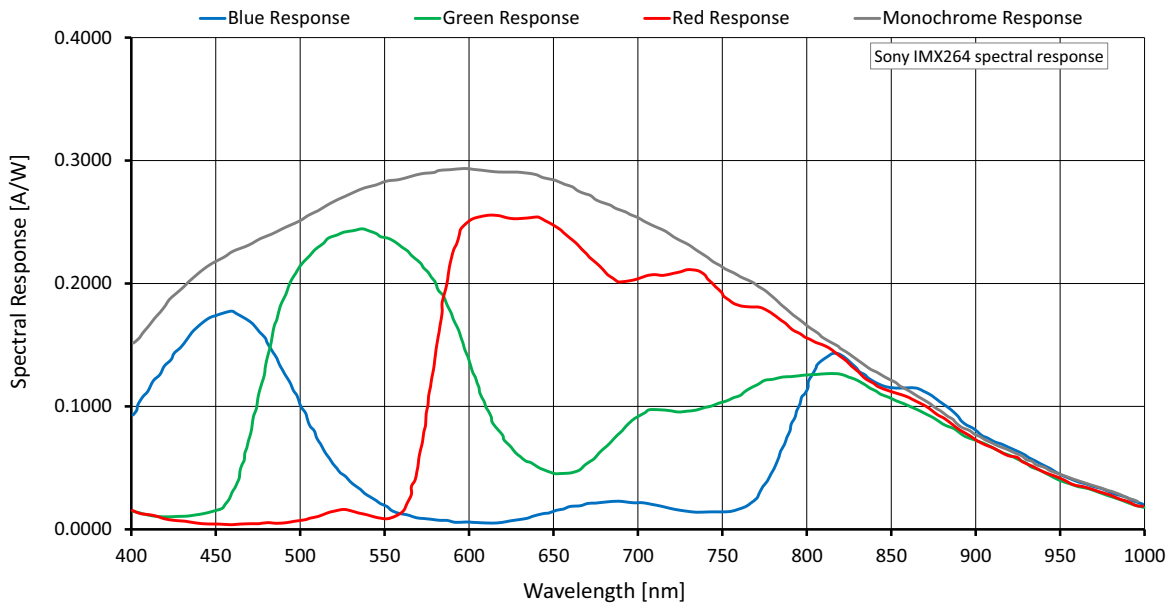

Figure 39: Alvium 1800 C-507m/c (Sony IMX264) spectral response

Frame rates with Cropping

Values were calculated as defined in [Frame rates with ROI/Cropping](#) on page 66 and in [Operation for maximum frame rates](#) on page 68.

Frame rates at maximum bandwidth calculates for 1.051 Gbit/s per lane. To reach the maximum frame rate available for typical operation, the bandwidth for image traffic is at 2 lanes with 2.102 Gbit/s. Increasing the CSI-2 Lane Count value does not increase frame rates.

Image format	Width [pixels]	Height [pixels]	ROI area [MP]	Frame rate [fps] ¹		
				4-lane	2-lane	1-lane
				4.204 Gbit/s	2.102 Gbit/s	1.051 Gbit/s
Full resolution	2464	2056	5.066	34.9		25.1
QXGA	2048	1536	3.146	46.3		40.1
Full HD	1920	1080	2.074	64.9		59.9
UXGA	1600	1200	1.920		58.9	
WXGA+ ²	1440	904	1.302		77.1	
SXGA	1280	1024	1.311		68.6	
HD 720	1280	720	0.922		95.4	
XGA	1024	768	0.786		90.1	
SVGA	800	600	0.480		113.6	
VGA	640	480	0.307		139.5	
HVGA	480	320	0.154		200.2	
QVGA	320	240	0.077		257.3	
HQVGA	240	160	0.038		356.2	
QQVGA	160	120	0.019		441.0	
Max. × half ³	2464	1032	2.543	67.5		48.6
Max. × min.	2464	16	0.039	914.8		698.8
Min. × max.	16	2056	0.033		35.2	
Min. × min.	16	16	256 P		1157.8	

¹ Mono8 / RAW8 (GREY) or Bayer...8⁽²⁾ / RGB888 (RGB3) at 12-Bit readout
² The three dots... represent the colors of a Bayer pixel format, such as in BayerRG8.
³ Instead of 1,440 × 900
⁴ Instead of 2,464 × 1,028
 If resolutions were not available due to increments, frame rates relate to the next available resolution.

Table 55: Alvium 1800 C-507m/c ROI frame rates



Alvium 1800 C-508m/c

Red table border lines signal that **GenICam for CSI-2 Access** is required.

Feature	Specification	
	1800 C-508m (monochrome)	1800 C-508c (color)
Sensor model	Sony IMX250	
Resolution	2464 (H) x 2056 (V); 5.1 MP	
Sensor type	CMOS	
Shutter type	Global shutter (GS)	
Sensor size	Type 2/3; 8.5 mm x 7.1 mm; 11.1 mm diagonal	
Pixel size	3.45 μm x 3.45 μm	
CRA	0 deg	
Sensor bit depth (ADC)	8-bit, 10-bit, 12-bit; Adaptive (10-bit, 12-bit)	
Sensor bit depth (ADC)	12-bit	
Pixel formats, GenICam for CSI-2 Access		
Monochrome pixel formats	Mono8 (default), Mono10, Mono10p, Mono12, Mono12p	Mono8, Mono10, Mono10p, Mono12, Mono12p
YUV color pixel formats	Not applicable	YCbCr411_8_CbYYCrYY, YCbCr422_8_CbYCrY, YCbCr8_CbYCr
RGB color pixel formats	Not applicable	BGR8, RGB8 (default)
Raw color pixel formats	Not applicable	BayerRG8, BayerRG10, BayerRG10p, BayerRG12, BayerRG12p
Pixel formats, other access modes		
YUV color pixel formats	Not applicable	YUV422 8-bit (UYVY)
RGB color pixel formats	Default: RGB888 (RGB3)	
RAW pixel formats	RAW8 (GREY), RAW10 (Y10), RAW12 (Y12)	
Maximum frame rate	66 fps, using 4 lanes	
Exposure time	28 μs to 10 s (4 lanes)	
Exposure modes	Timed, TriggerControlled, TriggerWidth	
Gain	0 dB to 48 dB; 0.1 dB increments	
Digital binning	Horizontal: 1 to 8 columns; Vertical: 1 to 8 rows	
Sensor binning (H x V)	1 x 2 (<i>Sum</i>)	Not applicable
Image buffer (RAM)	256 KByte	
Non-volatile memory (Flash)	1024 KByte	
GPIOs	2 programmable GPIOs As direct inputs (push-pull): 0 to 5.5 VDC As direct outputs (push-pull): 0 to 3.3 VDC at 12 mA	
Power requirements	Power over MIPI CSI-2	

Table 56: Alvium 1800 C-508m/c specifications (sheet 1 of 2)

Feature	Specification			
	1800 C-508m/C			
Power consumption (typical, at 5 VDC)	2.8 W			
Storage temperature	-20 °C to +85 °C ambient temperature			
Operating temperature	Hardware option	Housing	Cooling area¹	Mainboard²
	Bare board ³	Not applicable	-20 °C to +85 °C	-20 °C to +85 °C
	Open housing ⁴	-20 °C to +65 °C		
Relative humidity	0% to 80% (non-condensing)			
Digital interface	MIPI CSI-2 D-PHY V1.1; 1, 2, or 4 lanes; maximum 1.051 Gbit/s per lane			
Camera controls	GenICam (GenICam for CSI-2 Access) V4L2 controls (Video4Linux Access), Direct Register Access			
¹ See Mounting the heat sink on page 236. ² Output by DeviceTemperature ³ Ensure that the sensor is operated in the temperature range specified by the manufacturer. For any questions, please visit www.alliedvision.com/en/support . ⁴ Temperature values must be observed for the housing and for the cooling area.				

Table 56: Alvium 1800 C-508m/c specifications (sheet 2 of 2)

Absolute QE

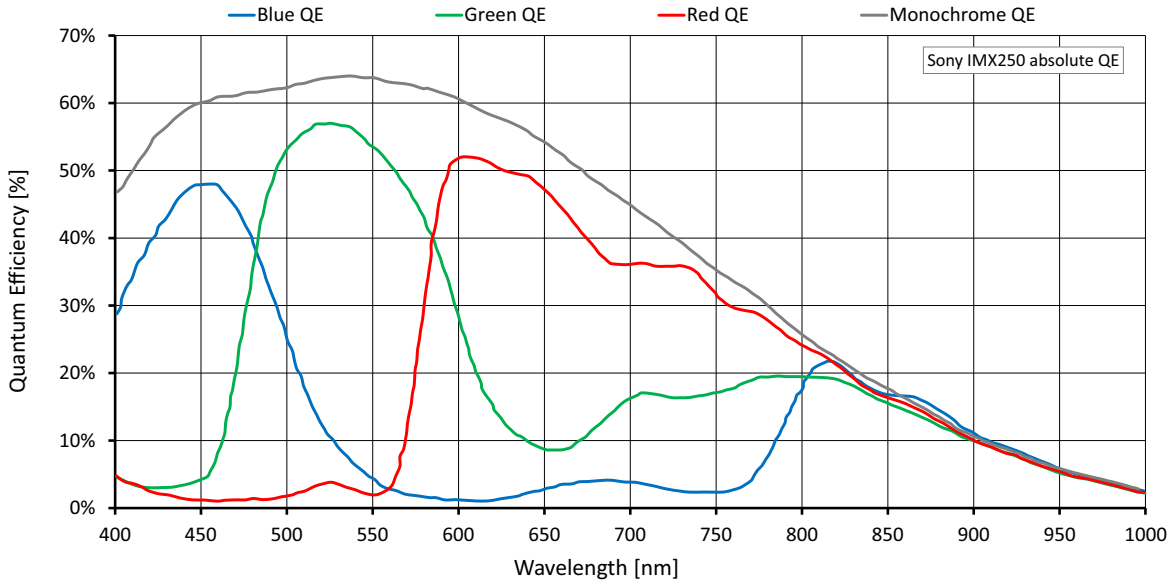

Figure 40: Alvium 1800 C-508m/c (Sony IMX250) absolute QE

Spectral response

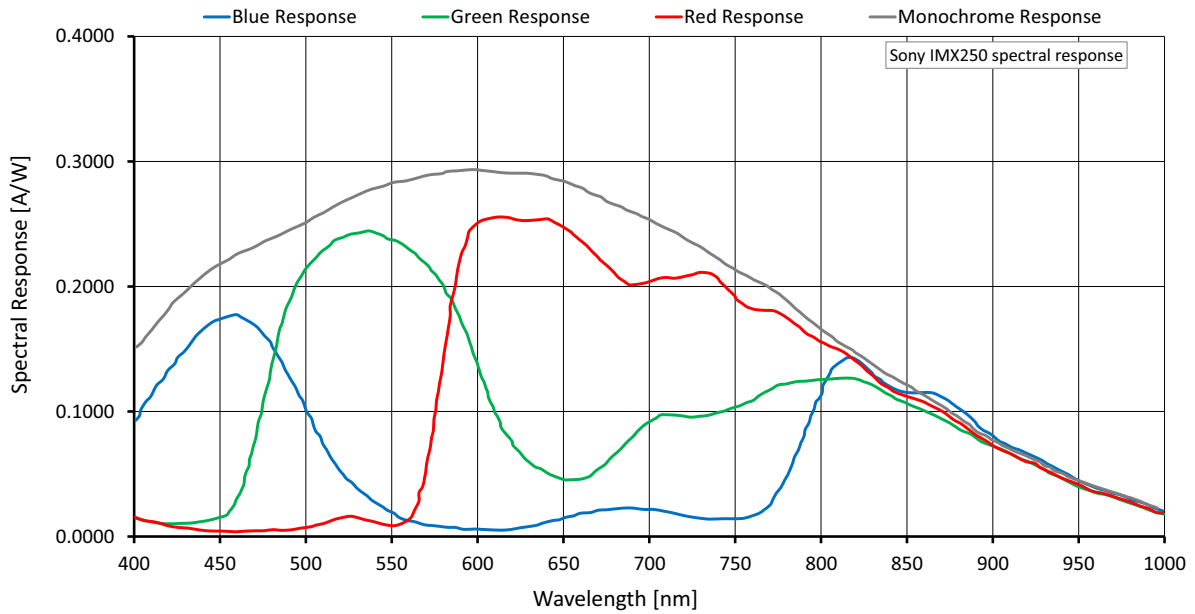

Figure 41: Alvium 1800 C-508m/c (Sony IMX250) spectral response

Frame rates with Cropping

Values were calculated as defined in [Frame rates with ROI/Cropping](#) on page 66 and in [Operation for maximum frame rates](#) on page 68.

Frame rates at maximum bandwidth calculates for 1.051 Gbit/s per lane. To reach the maximum frame rate available for typical operation, the bandwidth for image traffic is at 4 lanes with 4.204 Gbit/s.

Image format	Width [pixels]	Height [pixels]	ROI area [MP]	Frame rate [fps] ¹		
				4-lane	2-lane	1-lane
				4.204 Gbit/s	2.102 Gbit/s	1.051 Gbit/s
Full resolution	2464	2056	5.066	66.2	49.5	25.0
QXGA	2048	1536	3.146	87.8	78.9	40.0
Full HD	1920	1080	2.074	122.4	117.2	59.7
UXGA	1600	1200	1.920	111.4		64.8
WXGA+ ²	1440	904	1.302	145.5		94.0
SXGA	1280	1024	1.311	129.9		94.0
HD 720	1280	720	0.922	179.8		130.4
XGA	1024	768	0.786	170.5		153.3
SVGA	800	600	0.480	214.8		
VGA	640	480	0.307	263.9		
HVGA	480	320	0.154	378.3		
QVGA	320	240	0.077	483.8		
HQVGA	240	160	0.038	667.8		
QQVGA	160	120	0.019	822.2		
Max. × half ³	2464	1032	2.543	126.6	95.1	48.4
Max. × min.	2464	16	0.039	1329.3	1101.7	663.8
Min. × max.	16	2056	0.033	67.4		
Min. × min.	16	16	256 P	2061.4		

¹ RAW8 (GREY) or RGB888 (RGB3) at 12-Bit readout

² Instead of 1,440 × 900

³ Instead of 2,464 × 1,028

If resolutions were not available due to increments, frame rates relate to the next available resolution.

Table 57: Alvium 1800 C-508m/c ROI frame rates



Maximum frame rates with SensorBitDepth

Alvium 1800 C-508 can run higher frame rates than with ADC bit depth when **SensorBitDepth** is enabled. These values will be added in a future version of this document.



Alvium 1800 C-510m/c

Red table border lines signal that **GenICam for CSI-2 Access** is required.

Feature	Specification	
	1800 C-510m (monochrome)	1800 C-510c (color)
Sensor model	Sony IMX548	
Resolution	2464 (H) × 2064 (V); 5.1 MP	
Sensor type	CMOS	
Shutter type	Global shutter (GS)	
Sensor size	Type 1/1.8; 6.75 mm × 5.66 mm; 8.8 mm diagonal	
Pixel size	2.74 μm × 2.74 μm	
CRA	0 deg	
Sensor bit depth (ADC)	12-bit	
Pixel formats, GenICam for CSI-2 Access		
Monochrome pixel formats	Mono8 (default), Mono10, Mono10p, Mono12, Mono12p	Mono8, Mono10, Mono10p, Mono12, Mono12p
YUV color pixel formats	Not applicable	YCbCr411_8_CbYYCrYY, YCbCr422_8_CbYCrY, YCbCr8_CbYCr
RGB color pixel formats	Not applicable	BGR8, RGB8 (default)
Raw color pixel formats	Not applicable	BayerRG8, BayerRG10, BayerRG10p, BayerRG12, BayerRG12p
Pixel formats, other access formats		
YUV color pixel formats	Not applicable	YUV422 8-bit (UYVY)
RGB color pixel formats	Default: RGB888 (RGB3)	
RAW pixel formats	RAW8 (GREY), RAW10 (Y10), RAW12 (Y12)	
Maximum frame rate	81 fps, using 4 lanes	
Exposure time	14 μs to 10 s (4 lanes)	
Exposure modes	Timed	
Gain	0 dB to 48 dB; 0.1 dB increments	
Digital binning	Horizontal: 1 to 8 columns; Vertical: 1 to 8 rows	
Sensor binning (H × V)	2 × 2 (<i>Sum</i>)	Not applicable
Image buffer (RAM)	256 KByte	
Non-volatile memory (Flash)	1024 KByte	
GPIOs	2 programmable GPIOs As direct inputs (push-pull): 0 to 5.5 VDC As direct outputs (push-pull): 0 to 3.3 VDC at 12 mA	
Power requirements	Power over MIPI CSI-2	

Table 58: Alvium 1800 C-510m/c specifications (sheet 1 of 2)

Feature	Specification			
	1800 C-510m/c			
Power consumption (typical, at 5 VDC)	2.8 W			
Storage temperature	-20 °C to +85 °C ambient temperature			
Operating temperature	Hardware option	Housing	Cooling area¹	Mainboard²
	Bare board ³	Not applicable	-20 °C to +85 °C	-20 °C to +85 °C
	Open housing ⁴	-20 °C to +65 °C		
Relative humidity	0% to 80% (non-condensing)			
Digital interface	MIPI CSI-2 D-PHY V1.1; 1, 2, or 4 lanes; maximum 1.051 Gbit/s per lane			
Camera controls	GenICam (GenICam for CSI-2 Access)			
	V4L2 controls (Video4Linux Access), Direct Register Access			
¹ See Mounting the heat sink on page 236. ² Output by <code>DeviceTemperature</code> ³ Ensure that the sensor is operated in the temperature range specified by the manufacturer. For any questions, please visit www.alliedvision.com/en/support . ⁴ Temperature values must be observed for the housing and for the cooling area.				

Table 58: Alvim 1800 C-510m/c specifications (sheet 2 of 2)

Absolute QE

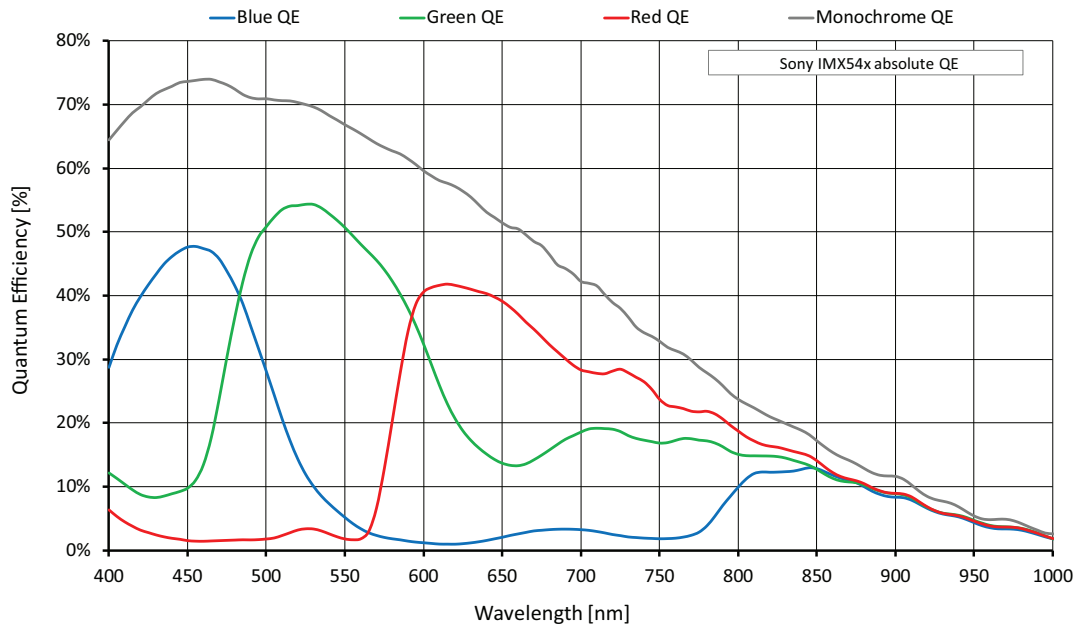

Figure 42: Alvium 1800 C-510m/c (Sony IMX548) absolute QE

Spectral response

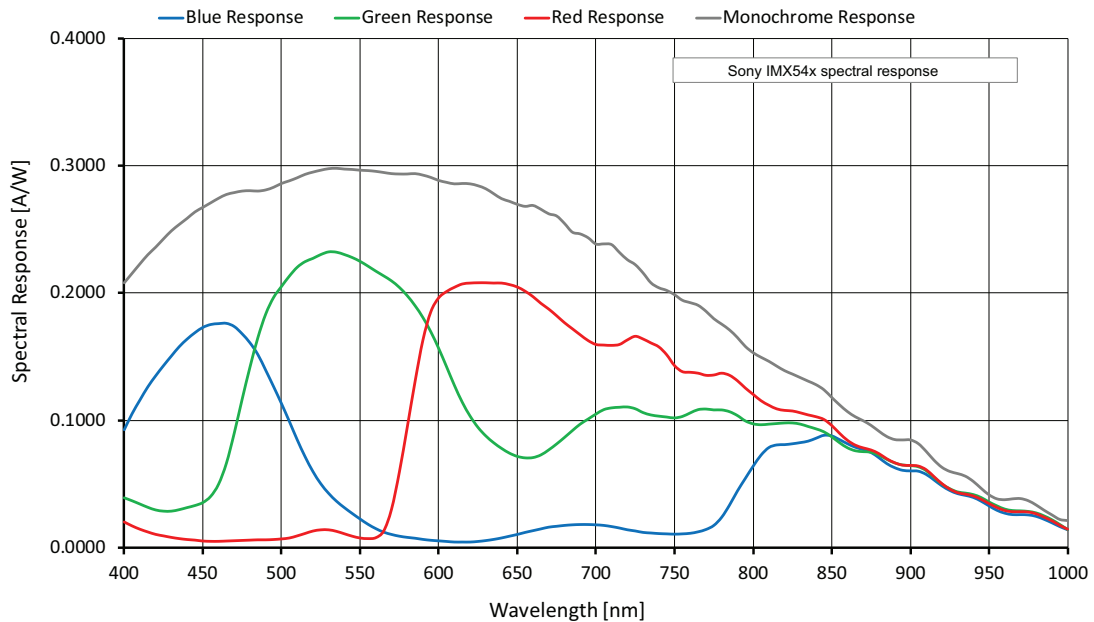

Figure 43: Alvium 1800 C-510m/c (Sony IMX548) spectral response

Frame rates with Cropping

Values were calculated as defined in [Frame rates with ROI/Cropping](#) on page 66 and in [Operation for maximum frame rates](#) on page 68.

Frame rates at maximum bandwidth calculates for 1.051 Gbit/s per lane. To reach the maximum frame rate available for typical operation, the bandwidth for image traffic is at 4 lanes with 4.204 Gbit/s.

Image format	Width [pixels]	Height [pixels]	ROI area [MP]	Frame rate [fps] ¹		
				4-lane	2-lane	1-lane
				4.204 Gbit/s	2.102 Gbit/s	1.051 Gbit/s
Full resolution	2464	2064	5.086	81.5	47.3	23.8
QXGA	2048	1536	3.146	106.7	74.8	37.6
Full HD	1920	1080	2.074	145.5	108.7	54.8
UXGA	1600	1200	1.920	133.3	118.4	60.1
WXGA+ ²	1440	904	1.302	170.1	168.5	85.1
SXGA	1280	1024	1.311	153.5		86.2
HD 720	1280	720	0.922	205.8		115.8
XGA	1024	768	0.786	196.1		137.2
SVGA	800	600	0.480	239.9		214.7
VGA	640	480	0.307	285.3		
HVGA	480	320	0.154	380.5		
QVGA	320	240	0.077	456.0		
HQVGA	240	160	0.038	569.0		
QQVGA	160	120	0.019	649.4		
Max. × half ³	2464	1032	2.543	150.2	87.8	44.4
Max. × min.	2464	16	0.039	887.8	555.3	295.4
Min. × max.	16	2064	0.033	82.5		
Min. × min.	16	16	256 P	1026.7		

¹ Mono8 / RAW8 (GREY) or Bayer...8⁽²⁾ / RGB888 (RGB3) at 12-Bit readout

² The three dots... represent the colors of a Bayer pixel format, such as in Bayer**RG**8.

³ Instead of 1,440 × 900

If resolutions were not available due to increments, frame rates relate to the next available resolution.

Table 59: Alvim 1800 C-510m/c ROI frame rates



Alvium 1800 C-511m/c

Red table border lines signal that **GeniCam for CSI-2 Access** is required.

Feature	Specification	
	1800 C-511m (monochrome)	1800 C-511c (color)
Sensor model	Sony IMX547	
Resolution	2464 (H) × 2064 (V); 5.1 MP	
Sensor type	CMOS	
Shutter type	Global shutter (GS)	
Sensor size	Type 1/1.8; 6.75 mm × 5.66 mm; 8.8 mm diagonal	
Pixel size	2.74 μm × 2.74 μm	
CRA	0 deg	
ADC bit depth	12-bit	
Pixel formats, GeniCam for CSI-2 Access		
Monochrome pixel formats	Mono8 (default), Mono10, Mono10p, Mono12, Mono12p	Mono8, Mono10, Mono10p, Mono12, Mono12p
YUV color pixel formats	Not applicable	YCbCr411_8_CbYYCrYY, YCbCr422_8_CbYCrY, YCbCr8_CbYCr
RGB color pixel formats	Not applicable	BGR8, RGB8 (default)
Raw color pixel formats	Not applicable	BayerRG8, BayerRG10, BayerRG10p, BayerRG12, BayerRG12p
Pixel formats, other access modes		
YUV color pixel formats	Not applicable	YUV422 8-bit (UYVY)
RGB color pixel formats	Default: RGB888 (RGB3)	
RAW pixel formats	RAW8 (GREY), RAW10 (Y10), RAW12 (Y12)	
Maximum frame rate	79 fps, using 4 lanes	
Exposure time	14 μs to 10 s (4 lanes)	
Exposure modes	Timed, TriggerControlled, TriggerWidth	
Gain	0 dB to 48 dB; 0.1 dB increments	
Digital binning	Horizontal: 1 to 8 columns; Vertical: 1 to 8 rows	
Sensor binning (H × V)	2 × 2 (<i>Sum</i>)	Not applicable
Image buffer (RAM)	256 KByte	
Non-volatile memory (Flash)	1024 KByte	
GPIOs	2 programmable GPIOs As direct inputs (push-pull): 0 to 5.5 VDC As direct outputs (push-pull): 0 to 3.3 VDC at 12 mA	
Power requirements	Power over MIPI CSI-2	

Table 60: Alvium 1800 C-511m/c specifications (sheet 1 of 2)

Feature	Specification			
	1800 C-511m/c			
Power consumption (typical, at 5 VDC)	3.0 W			
Storage temperature	-20 °C to +85 °C ambient temperature			
Operating temperature	Hardware option	Housing	Cooling area¹	Mainboard²
	Bare board ³	Not applicable	-20 °C to +85 °C	-20 °C to +85 °C
	Open housing ⁴	-20 °C to +65 °C		
Relative humidity	0% to 80% (non-condensing)			
Digital interface	MIPI CSI-2 D-PHY V1.1; 1, 2, or 4 lanes; maximum 1.051 Gbit/s per lane			
Camera controls	GenICam (GenICam for CSI-2 Access)			
	V4L2 controls (Video4Linux Access), Direct Register Access			
¹ See Mounting the heat sink on page 236. ² Output by <code>DeviceTemperature</code> ³ Ensure that the sensor is operated in the temperature range specified by the manufacturer. For any questions, please visit www.alliedvision.com/en/support . ⁴ Temperature values must be observed for the housing and for the cooling area.				

Table 60: Alvium 1800 C-511m/c specifications (sheet 2 of 2)

Absolute QE

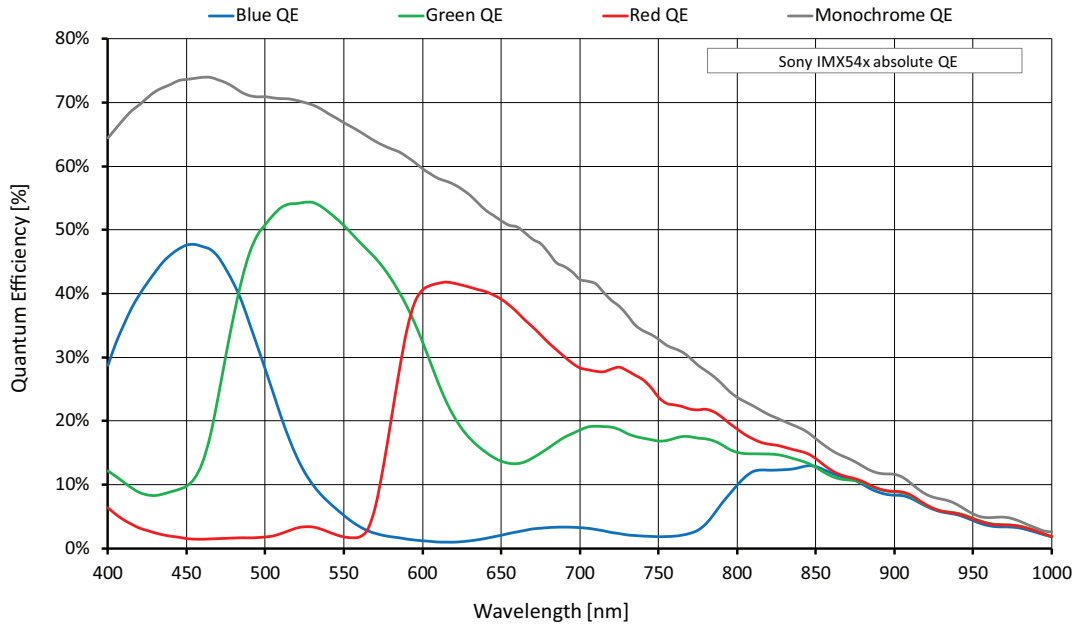

Figure 44: Alvium 1800 C-511m/c (Sony IMX547) absolute QE

Spectral response

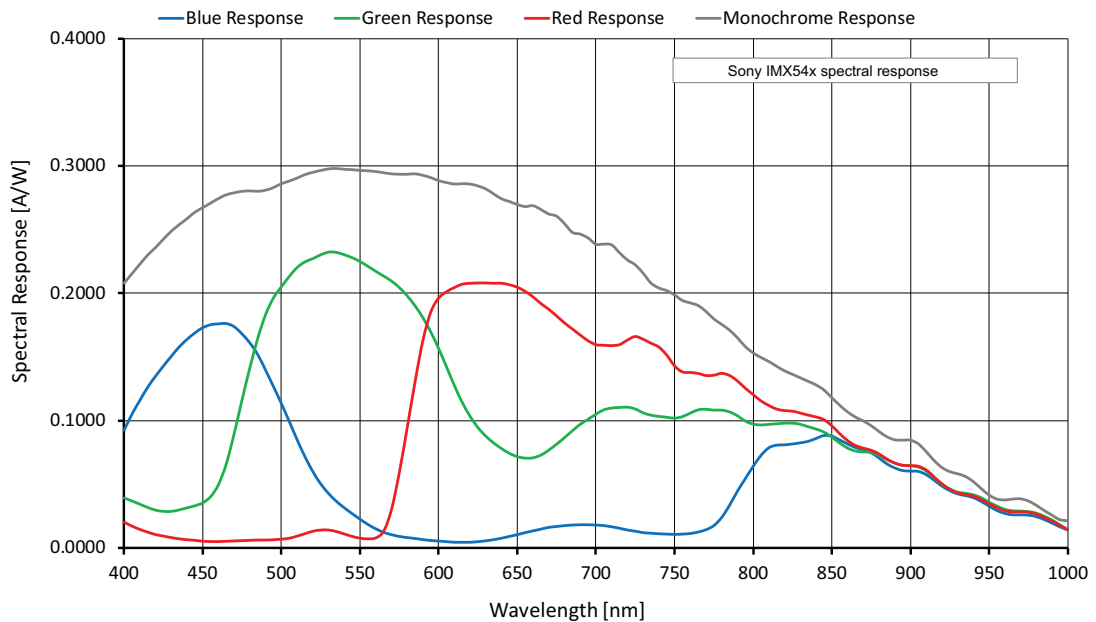

Figure 45: Alvium 1800 C-511m/c (Sony IMX547) spectral response

Frame rates with Cropping

Values were calculated as defined in [Frame rates with ROI/Cropping](#) on page 66 and in [Operation for maximum frame rates](#) on page 68.

Frame rates at maximum bandwidth calculates for 1.051 Gbit/s per lane. To reach the maximum frame rate available for typical operation, the bandwidth for image traffic is at 4 lanes with 4.204 Gbit/s.

Image format	Width [pixels]	Height [pixels]	ROI area [MP]	Frame rate [fps] ¹		
				4-lane	2-lane	1-lane
				4.204 Gbit/s	2.102 Gbit/s	1.051 Gbit/s
Full resolution	2464	2064	5.086	79.9	47.3	23.8
QXGA	2048	1536	3.146	104.7	74.8	37.6
Full HD	1920	1080	2.074	142.8	108.7	54.8
UXGA	1600	1200	1.920	130.7	118.4	60.1
WXGA+ ²	1440	904	1.302	167.0		85.1
SXGA	1280	1024	1.311	150.5		86.2
HD 720	1280	720	0.922	201.8		115.8
XGA	1024	768	0.786	192.3		137.2
SVGA	800	600	0.480	235.2		214.7
VGA	640	480	0.307	280.2		
HVGA	480	320	0.154	373.1		
QVGA	320	240	0.077	447.1		
HQVGA	240	160	0.038	557.9		
QQVGA	160	120	0.019	636.8		
Max. × half ³	2464	1032	2.543	147.3	87.8	44.4
Max. × min.	2464	16	0.039	870.6	555.3	295.4
Min. × max.	16	2064	0.033	80.9		
Min. × min.	16	16	256 P	1006.8		

¹ Mono8 / RAW8 (GREY) or Bayer...8⁽²⁾ / RGB888 (RGB3) at 12-Bit readout

² The three dots... represent the colors of a Bayer pixel format, such as in Bayer**RG**8.

³ Instead of 1,440 × 900

If resolutions were not available due to increments, frame rates relate to the next available resolution.

Table 61: Alvium 1800 C-511m/c ROI frame rates



Alvium 1800 C-811m/c

Red table border lines signal that **GeniCam for CSI-2 Access** is required.

Feature	Specification	
	1800 C-811m (monochrome)	1800 C-811c (color)
Sensor model	Sony IMX546	
Resolution	2848 (H) × 2848 (V); 8.1 MP	
Sensor type	CMOS	
Shutter type	Global shutter (GS)	
Sensor size	Type 2/3; 7.8 mm × 7.8 mm; 11 mm diagonal	
Pixel size	2.74 μm × 2.74 μm	
CRA	0 deg	
Sensor bit depth (ADC)	12-bit	
	Pixel formats, GeniCam for CSI-2 Access	
Monochrome pixel formats	Mono8 (default), Mono10, Mono10p, Mono12, Mono12p	Mono8, Mono10, Mono10p, Mono12, Mono12p
YUV color pixel formats	Not applicable	YCbCr411_8_CbYYCrYY, YCbCr422_8_CbYCrY, YCbCr8_CbYCr
RGB color pixel formats	Not applicable	BGR8, RGB8 (default)
Raw color pixel formats	Not applicable	BayerRG8, BayerRG10, BayerRG10p, BayerRG12, BayerRG12p
	Pixel formats, other access modes	
YUV color pixel formats	Not applicable	YUV422 8-bit (UYVY)
RGB color pixel formats	Default: RGB888 (RGB3)	
RAW pixel formats	RAW8 (GREY), RAW10 (Y10), RAW12 (Y12)	
Maximum frame rate	59 fps, using 4 lanes	
Exposure time	14 μs to 10 s (4 lanes)	
Exposure modes	Timed, TriggerControlled, TriggerWidth	
Gain	0 dB to 48 dB; 0.1 dB increments	
Digital binning	Horizontal: 1 to 8 columns; Vertical: 1 to 8 rows	
Sensor binning (H × V)	2 × 2 (<i>Sum</i>)	Not applicable
Image buffer (RAM)	256 KByte	
Non-volatile memory (Flash)	1024 KByte	
GPIOs	2 programmable GPIOs As direct inputs (push-pull): 0 to 5.5 VDC As direct outputs (push-pull): 0 to 3.3 VDC at 12 mA	
Power requirements	Power over MIPI CSI-2	

Table 62: Alvium 1800 C-811m/c specifications (sheet 1 of 2)

Feature	Specification			
	1800 C-811m/c			
Power consumption (typical, at 5 VDC)	3.1 W			
Storage temperature	-20 °C to +85 °C ambient temperature			
Operating temperature	Hardware option	Housing	Cooling area¹	Mainboard²
	Bare board ³	Not applicable	-20 °C to +85 °C	-20 °C to +85 °C
	Open housing ⁴	-20 °C to +65 °C		
Relative humidity	0% to 80% (non-condensing)			
Digital interface	MIPI CSI-2 D-PHY V1.1; 1, 2, or 4 lanes; maximum 1.051 Gbit/s per lane			
Camera controls	GenICam (GenICam for CSI-2 Access)			
	V4L2 controls (Video4Linux Access), Direct Register Access			
¹ See Mounting the heat sink on page 236. ² Output by DeviceTemperature ³ Ensure that the sensor is operated in the temperature range specified by the manufacturer. For any questions, please visit www.alliedvision.com/en/support . ⁴ Temperature values must be observed for the housing and for the cooling area.				

Table 62: Alvium 1800 C-811m/c specifications (sheet 2 of 2)

Absolute QE

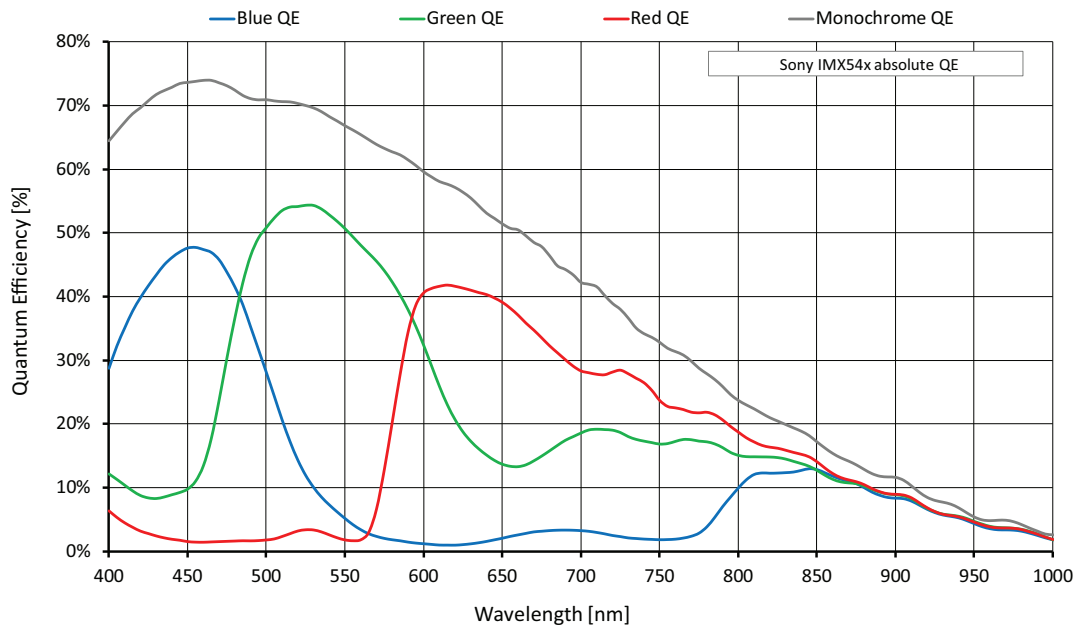

Figure 46: Alvium 1800 C-811m/c (Sony IMX546) absolute QE

Spectral response

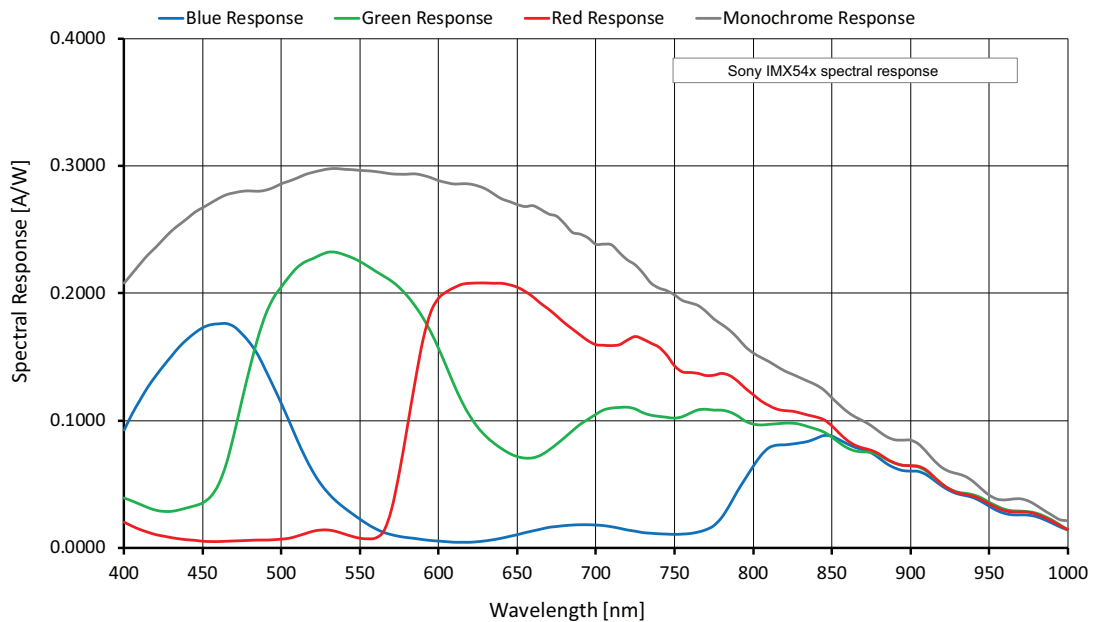

Figure 47: Alvium 1800 C-811m/c (Sony IMX546) spectral response

Frame rates with Cropping

Values were calculated as defined in [Frame rates with ROI/Cropping](#) on page 66 and in [Operation for maximum frame rates](#) on page 68.

Frame rates at maximum bandwidth calculates for 1.051 Gbit/s per lane. To reach the maximum frame rate available for typical operation, the bandwidth for image traffic is at 4 lanes with 4.204 Gbit/s.

Image format	Width [pixels]	Height [pixels]	ROI area [MP]	Frame rate [fps] ¹		
				4-lane	2-lane	1-lane
				4.204 Gbit/s	2.102 Gbit/s	1.051 Gbit/s
Full resolution	2848	2848	8.111	59.2	30.4	15.2
QSXGA	2560	2048	5.243	80.4	46.1	23.1
WQHD	2560	1440	3.686	110.4	63.5	31.9
QXGA	2048	1536	3.146	104.7	74.8	37.6
Full HD	1920	1080	2.074	142.8	108.7	54.8
UXGA	1600	1200	1.920	130.7	118.4	60.1
WXGA+ ²	1440	904	1.302	167.0		85.1
SXGA	1280	1024	1.311	150.5		86.2
HD 720	1280	720	0.922	201.8		115.8
XGA	1024	768	0.786	192.3		137.2
SVGA	800	600	0.480	235.2		214.7
VGA	640	480	0.307	280.2		
HVGA	480	320	0.154	373.1		
QVGA	320	240	0.077	447.1		
HQVGA	240	160	0.038	557.9		
QQVGA	160	120	0.019	636.8		
Max. × half ³	2848	1424	4.056	111.2	57.4	29.0
Max. × min.	2848	16	0.046	850.0	481.1	255.8
Min. × max.	16	2848	0.046	59.8		
Min. × min.	16	16	256 P	1006.8		

¹ RAW8 (GREY) or RGB888 (RGB3) at 12-Bit readout
² Instead of 1,440 × 900
 If resolutions were not available due to increments, frame rates relate to the next available resolution.

Table 63: Alvium 1800 C-811m/c ROI frame rates



Alvium 1800 C-812 UV

Red table border lines signal that **GenICam for CSI-2 Access** is required.



NOTICE

Sensor aging by UV radiation

The sensor in this camera model is dedicated for imaging in the UV spectrum. However, UV radiation causes aging, which is permanently increasing the dark current and decreasing the QE (quantum efficiency).

To reduce sensor aging, we recommend you to:

- Minimize the intensity of UV radiation.
- Avoid wavelengths below 250 nm. For example, consider the use of bandpass filters to block shorter wavelengths.

Feature	Specification
1800 C-812 UV	
Sensor model	Sony IMX487
Resolution	2848 (H) × 2848 (V); 8.1 MP
Sensor type	CMOS
Shutter type	Global shutter (GS)
Sensor size	Type 2/3; 7.8 mm × 7.8 mm; 11 mm diagonal
Pixel size	2.74 μm × 2.74 μm
CRA	0 deg
Sensor bit depth (ADC)	12-bit
Pixel formats, GenICam for CSI-2 Access	
Monochrome pixel formats	Mono8 (default), Mono10, Mono10p, Mono12, Mono12p
Pixel formats, other access modes	
RAW pixel formats	RAW8 (GREY), RAW10 (Y10), RAW12 (Y12)
Maximum frame rate	58 fps, using 4 lanes
Exposure time	14 μs to 10 s (4 lanes)
Exposure modes	Timed, TriggerControlled, TriggerWidth
Gain	0 dB to 48 dB; 0.1 dB increments
Digital binning	Horizontal: 1 to 8 columns; Vertical: 1 to 8 rows
Sensor binning (H × V)	2 × 2 (<i>Sum</i>) Not applicable
Image buffer (RAM)	256 KByte
Non-volatile memory (Flash)	1024 KByte
GPIOs	2 programmable GPIOs As direct inputs (push-pull): 0 to 5.5 VDC As direct outputs (push-pull): 0 to 3.3 VDC at 12 mA
Power requirements	Power over MIPI CSI-2

Table 64: Alvium 1800 C-812 UV specifications (sheet 1 of 2)

Feature	Specification			
	1800 C-812 UV			
Power consumption (typical, at 5 VDC)	3.7 W			
Storage temperature	-20 °C to +85 °C ambient temperature			
Operating temperature	Hardware option	Housing	Cooling area¹	Mainboard²
	Bare board ³	Not applicable	-20 °C to +85 °C	-20 °C to +85 °C
	Open housing ⁴	-20 °C to +65 °C		
Relative humidity	0% to 80% (non-condensing)			
Digital interface	MIPI CSI-2 D-PHY V1.1; 1, 2, or 4 lanes; maximum 1.051 Gbit/s per lane			
Camera controls	GenICam (GenICam for CSI-2 Access) V4L2 controls (Video4Linux Access), Direct Register Access			
¹ See Mounting the heat sink on page 236. ² Output by <code>DeviceTemperature</code> ³ Ensure that the sensor is operated in the temperature range specified by the manufacturer. For any questions, please visit www.alliedvision.com/en/support . ⁴ Temperature values must be observed for the housing and for the cooling area.				

Table 64: Alvium 1800 C-812 UV specifications (sheet 2 of 2)

Absolute QE

Diagrams will be added in a future version of this document.

Spectral response

Diagrams will be added in a future version of this document.

Frame rates with Cropping

Values were calculated as defined in [Frame rates with ROI/Cropping](#) on page 66 and in [Operation for maximum frame rates](#) on page 68.

Frame rates at maximum bandwidth calculates for 1.051 Gbit/s per lane. To reach the maximum frame rate available for typical operation, the bandwidth for image traffic is at 4 lanes with 4.204 Gbit/s.

Image format	Width [pixels]	Height [pixels]	ROI area [MP]	Frame rate [fps] ¹		
				4-lane	2-lane	1-lane
				4.204 Gbit/s	2.102 Gbit/s	1.051 Gbit/s
Full resolution	2848	2848	8.111	58.8	30.2	15.1
QSXGA	2560	2048	5.243	79.7	45.7	22.9
WQHD	2560	1440	3.686	109.0	62.7	31.5
QXGA	2048	1536	3.146	103.5	73.9	37.2
Full HD	1920	1080	2.074	139.7	106.3	53.6
UXGA	1600	1200	1.920	128.9	116.7	59.3
WXGA+ ²	1440	904	1.302	162.8		82.9
SXGA	1280	1024	1.311	148.0		84.8
HD 720	1280	720	0.922	197.3		113.3
XGA	1024	768	0.786	188.3		134.3
SVGA	800	600	0.480	226.9		207.1
VGA	640	480	0.307	271.8		
HVGA	480	320	0.154	358.2		
QVGA	320	240	0.077	426.0		
HQVGA	240	160	0.038	525.4		
QQVGA	160	120	0.019	579.4		
Max. × half	2848	1424	4.056	109.8	56.7	28.6
Max. × min.	2848	16	0.046	776.8	435.5	230.3
Min. × max.	16	2848	0.046	59.4		
Min. × min.	16	16	256 P	905.6		

¹ RAW8 (GREY) or RGB888 (RGB3) at 12-Bit readout

² Instead of 1,440 × 900

If resolutions were not available due to increments, frame rates relate to the next available resolution.

Table 65: Alvium 1800 C-812 UV ROI frame rates



Alvium 1800 C-895m/c

Red table border lines signal that **GeniCam for CSI-2 Access** is required.

Feature	Specification	
	1800 C-895m (monochrome)	1800 C-895c (color)
Sensor model	Sony IMX267	
Resolution	4112 (H) × 2176 (V); 8.95 MP	
Sensor type	CMOS	
Shutter type	Global shutter (GS)	
Sensor size	Type 1; 14.2 mm × 7.5 mm; 16 mm diagonal	
Pixel size	3.45 μm × 3.45 μm	
CRA	0 deg	
ADC bit depth	12-bit	
	Pixel formats, GeniCam for CSI-2 Access	
Monochrome pixel formats	Mono8 (default), Mono10, Mono10p, Mono12, Mono12p	Mono8, Mono10, Mono10p, Mono12, Mono12p
YUV color pixel formats	Not applicable	YCbCr411_8_CbYYCrYY, YCbCr422_8_CbYCrY, YCbCr8_CbYCr
RGB color pixel formats	Not applicable	BGR8, RGB8 (default)
Raw color pixel formats	Not applicable	BayerRG8, BayerRG10, BayerRG10p, BayerRG12, BayerRG12p
	Pixel formats, other access modes	
YUV color pixel formats	Not applicable	YUV422 8-bit (UYVY)
RGB color pixel formats	Default: RGB888 (RGB3)	
RAW pixel formats	RAW8 (GREY), RAW10 (Y10), RAW12 (Y12)	
Maximum frame rate	31 fps, using 4 lanes	
Exposure time	43 μs to 10 s (4 lanes)	
Exposure modes	Timed, TriggerControlled, TriggerWidth	
Gain	0 dB to 48 dB; 0.1 dB increments	
Digital binning ¹	Horizontal: 1 to 8 columns; Vertical: 1 to 8 rows	
Image buffer (RAM)	256 KByte	
Non-volatile memory (Flash)	1024 KByte	
GPIOs	2 programmable GPIOs As direct inputs (push-pull): 0 to 5.5 VDC As direct outputs (push-pull): 0 to 3.3 VDC at 12 mA	
¹ Digital vertical binning can be used only when digital horizontal binning is used as well		

Table 66: Alvium 1800 C-895m/c specifications (sheet 1 of 2)

Feature	Specification			
	1800 C-895m/c			
Power requirements	Power over MIPI CSI-2			
Power consumption (typical, at 5 VDC)	2.6 W			
Storage temperature	-20 °C to +85 °C ambient temperature			
Operating temperature	Hardware option	Housing	Cooling area²	Mainboard³
	Bare board ⁴	Not applicable	-20 °C to +85 °C	-20 °C to +88 °C
	Open housing ⁵	-20 °C to +65 °C		
Relative humidity	0% to 80% (non-condensing)			
Digital interface	MIPI CSI-2 D-PHY V1.1; 1, 2, or 4 lanes; maximum 1.051 Gbit/s per lane			
Camera controls	GenICam (GenICam for CSI-2 Access)			
	V4L2 controls (Video4Linux Access), Direct Register Access			
² See Mounting the heat sink on page 236.				
³ Output by <code>DeviceTemperature</code>				
⁴ Ensure that the sensor is operated in the temperature range specified by the manufacturer. For any questions, please visit www.alliedvision.com/en/support .				
⁵ Temperature values must be observed for the housing and for the cooling area.				

Table 66: Alvium 1800 C-895m/c specifications (sheet 2 of 2)

Absolute QE

Diagrams will be added in a future version of this document.

Spectral response

Diagrams will be added in a future version of this document.

Frame rates with Cropping

Values were calculated as defined in [Frame rates with ROI/Cropping](#) on page 66 and in [Operation for maximum frame rates](#) on page 68.

Frame rates at maximum bandwidth calculates for 1.051 Gbit/s per lane. To reach the maximum frame rate available for typical operation, the bandwidth for image traffic is at 4 lanes with 4.204 Gbit/s.

Image format	Width [pixels]	Height [pixels]	ROI area [MP]	Frame rate [fps] ¹		
				4-lane	2-lane	1-lane
				4.204 Gbit/s	2.102 Gbit/s	1.051 Gbit/s
Full resolution	4112	2176	8.948	31.5	28.3	14.3
UHD 4K	3840	2160	8.294	31.8	30.6	15.4
QSXGA	2560	2048	5.243	33.6		24.3
WQHD	2560	1440	3.686	47.2		34.1
QXGA	2048	1536	3.146	44.5		40.2
Full HD	1920	1080	2.074	62.3		60.0
UXGA	1600	1200	1.920	56.5		
WXGA+	1440	904	1.302	74.1		
SXGA	1280	1024	1.311	65.9		
HD 720	1280	720	0.922	91.8		
XGA	1024	768	0.786	86.6		
SVGA	800	600	0.480	109.2		
VGA	640	480	0.307	134.4		
HVGA	480	320	0.154	193.3		
QVGA	320	240	0.077	247.8		
HQVGA	240	160	0.038	345.2		
QQVGA	160	120	0.019	428.4		
Max. × half	4112	1088	4.474	60.9	54.8	27.8
Max. × min.	4112	16	0.066	740.8	693.4	419.7
Min. × max.	16	2176	0.035	32.0		
Min. × min.	16	16	256 P	1147.1		

¹ Mono8 / RAW8 (GREY) or Bayer...8⁽²⁾ / RGB888 (RGB3) at 12-Bit readout
² The three dots... represent the colors of a Bayer pixel format, such as in Bayer**RG8**.
³ Instead of 1,440 × 900
 If resolutions were not available due to increments, frame rates relate to the next available resolution.

Table 67: Alvium 1800 C-895m/c ROI frame rates



Alvium 1800 C-1236m/c

Red table border lines signal that **GeniCam for CSI-2 Access** is required.

Feature	Specification	
	1800 C-1236m (monochrome)	1800 C-1236c (color)
Sensor model	Sony IMX304	
Resolution	4112 (H) × 3008 (V); 12.4 MP	
Sensor type	CMOS	
Shutter type	Global shutter (GS)	
Sensor size	Type 1.1; 14.2 mm × 10.4 mm; 17.6 mm diagonal	
Pixel size	3.45 μm × 3.45 μm	
CRA	0 deg	
ADC bit depth	12-bit	
Pixel formats, GeniCam for CSI-2 Access		
Monochrome pixel formats	Mono8 (default), Mono10, Mono10p, Mono12, Mono12p,	Mono8, Mono10, Mono10p, Mono12, Mono12p
YUV color pixel formats	Not applicable	YCbCr411_8_CbYYCrYY, YCbCr422_8_CbYCrY, YCbCr8_CbYCr
RGB color pixel formats	Not applicable	BGR8, RGB8 (default)
Raw color pixel formats	Not applicable	BayerRG8, BayerRG10, BayerRG10p, BayerRG12, BayerRG12p
Pixel formats, other access modes		
YUV color pixel formats	Not applicable	YUV422 8-bit (UYVY)
RGB color pixel formats	Default: RGB888 (RGB3)	
RAW pixel formats	RAW8 (GREY), RAW10 (Y10), RAW12 (Y12)	
Maximum frame rate	22 fps, using 4 lanes	
Exposure time	43 μs to 10 s (4 lanes)	
Exposure modes	Timed, TriggerControlled, TriggerWidth	
Gain	0 dB to 48 dB; 0.1 dB increments	
Digital binning ¹	Horizontal: 1 to 8 columns; Vertical: 1 to 8 rows	
Image buffer (RAM)	256 KByte	
Non-volatile memory (Flash)	1024 KByte	
GPIOs	2 programmable GPIOs As direct inputs (push-pull): 0 to 5.5 VDC As direct outputs (push-pull): 0 to 3.3 VDC at 12 mA	
¹ Digital vertical binning can be used only when digital horizontal binning is used as well.		

Table 68: Alvium 1800 C-1236m/c specifications (sheet 1 of 2)

Feature	Specification			
	1800 C-1236m/c			
Power requirements	Power over MIPI CSI-2			
Power consumption (typical, at 5 VDC)	2.6 W			
Storage temperature	-20 °C to +85 °C ambient temperature			
Operating temperature	Hardware option	Housing	Cooling area²	Mainboard³
	Bare board ⁴	Not applicable	-20 °C to +85 °C	-20 °C to +88 °C
	Open housing ⁵	-20 °C to +65 °C		
Relative humidity	0% to 80% (non-condensing)			
Digital interface	MIPI CSI-2 D-PHY V1.1; 1, 2, or 4 lanes; maximum 1.051 Gbit/s per lane			
Camera controls	GenICam (GenICam for CSI-2 Access)			
	V4L2 controls (Video4Linux Access), Direct Register Access			
² See Mounting the heat sink on page 236.				
³ Output by <code>DeviceTemperature</code>				
⁴ Ensure that the sensor is operated in the temperature range specified by the manufacturer. For any questions, please visit www.alliedvision.com/en/support .				
⁵ Temperature values must be observed for the housing and for the cooling area.				

Table 68: Alvium 1800 C-1236m/c specifications (sheet 2 of 2)

Absolute QE

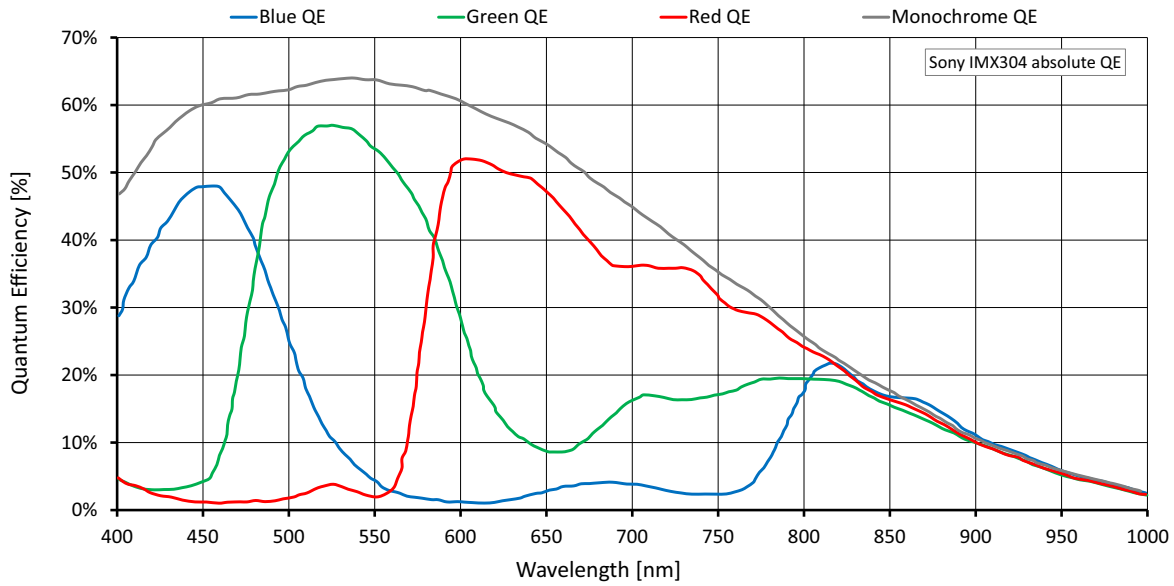

Figure 48: Alvium 1800 C-1236m/c (Sony IMX304) absolute QE

Spectral response

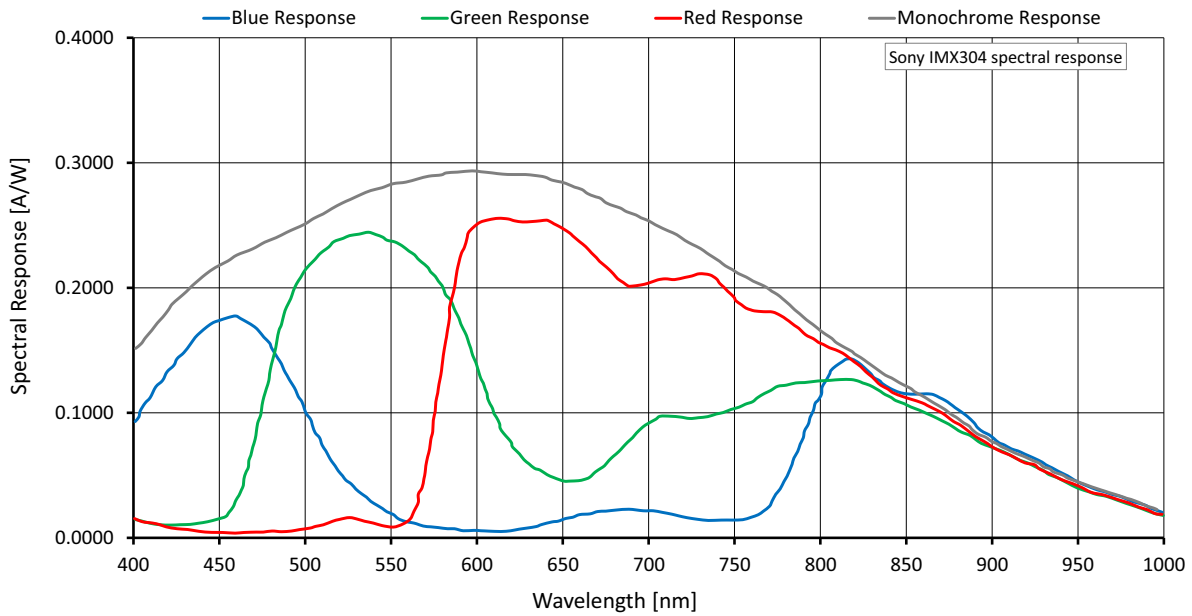

Figure 49: Alvium 1800 C-1236m/c (Sony IMX304) spectral response

Frame rates with Cropping

Values were calculated as defined in [Frame rates with ROI/Cropping](#) on page 66 and in [Operation for maximum frame rates](#) on page 68.

Frame rates at maximum bandwidth calculates for 1.051 Gbit/s per lane. To reach the maximum frame rate available for typical operation, the bandwidth for image traffic is at 4 lanes with 4.204 Gbit/s.

Image format	Width [pixels]	Height [pixels]	ROI area [MP]	Frame rate [fps] ¹		
				4-lane	2-lane	1-lane
				4.204 Gbit/s	2.102 Gbit/s	1.051 Gbit/s
Full resolution	4112	3008	12.369	22.9	20.6	10.3
UHD 4K	3840	2160	8.294	31.6	30.5	15.3
QXGA	2560	2048	5.243	33.5		24.1
WQHD	2560	1440	3.686	47.0		33.9
QXGA	2048	1536	3.146	44.3		40.0
Full HD	1920	1080	2.074	62.0		59.6
UXGA	1600	1200	1.920	56.2		
WXGA+ ²	1440	904	1.302	73.6		
SXGA	1280	1024	1.311	65.5		
HD 720	1280	720	0.922	91.0		
XGA	1024	768	0.786	86.0		
SVGA	800	600	0.480	108.2		
VGA	640	480	0.307	132.9		
HVGA	480	320	0.154	190.1		
QVGA	320	240	0.077	242.7		
HQVGA	240	160	0.038	335.4		
QQVGA	160	120	0.019	413.4		
Max. × half	4112	1504	6.184	44.7	40.2	20.3
Max. × min.	4112	16	0.066	697.2	650.9	388.9
Min. × max.	16	3008	0.048	23.2		
Min. × min.	16	16	256 P	1045.8		

¹ Mono8 / RAW8 (GREY) or Bayer...8⁽²⁾ / RGB888 (RGB3) at 12-Bit readout
² The three dots... represent the colors of a Bayer pixel format, such as in Bayer**RG8**.
³ Instead of 1,440 × 900
 If resolutions were not available due to increments, frame rates relate to the next available resolution.

Table 69: Alvium 1800 C-1236m/c ROI frame rates



Alvium 1800 C-1240m/c

Red table border lines signal that **GeniCam for CSI-2 Access** is required.

Feature	Specification	
	1800 C-1240m (monochrome)	1800 C-1240c (color)
Sensor model	Sony IMX226	
Resolution	4024 (H) x 3036 (V); 12.2 MP	
Sensor type	CMOS	
Shutter type	Rolling shutter (RS), Global reset shutter (GRS)	
Sensor size	Type 1/1.7; 7.4 mm x 5.6 mm; 9.33 mm diagonal	
Pixel size	1.85 μm x 1.85 μm	
CRA	0 deg	
Sensor bit depth (ADC)	10-bit	
Pixel formats, GeniCam for CSI-2 Access		
Monochrome pixel formats	Mono8 (default), Mono10, Mono10p, Mono12, Mono12p	Mono8, Mono10, Mono10p, Mono12, Mono12p
YUV color pixel formats	Not applicable	YCbCr411_8_CbYYCrYY, YCbCr422_8_CbYCrY, YCbCr8_CbYCr
RGB color pixel formats	Not applicable	BGR8, RGB8 (default)
Raw color pixel formats	Not applicable	BayerRG8, BayerRG10, BayerRG10p, BayerRG12, BayerRG12p
Pixel formats, other access modes		
YUV color pixel formats	Not applicable	YUV422 8-bit (UYVY)
RGB color pixel formats	Default: RGB888 (RGB3)	
RAW pixel formats	RAW8 (GREY), RAW10 (Y10)	
Maximum frame rate	41 fps ¹ , using 4 lanes	
Exposure time	12 μs to 10 s (4 lanes)	
Exposure modes	Timed	
Gain	0 dB to 27 dB; 0.1 dB increments	
Digital binning ²	Horizontal: 1 to 8 columns; Vertical: 1 to 8 rows	
Image buffer (RAM)	256 KByte	
Non-volatile memory (Flash)	1024 KByte	
GPIOs	2 programmable GPIOs As direct inputs (push-pull): 0 to 5.5 VDC As direct outputs (push-pull): 0 to 3.3 VDC at 12 mA	
¹ In triggered mode: ~41 fps		
² Digital vertical binning can be used only when digital horizontal binning is used as well.		

Table 70: Alvium 1800 C-1240m/c specifications (sheet 1 of 2)

Feature	Specification			
	1800 C-1240m/c			
Power requirements	Power over MIPI CSI-2			
Power consumption (typical, at 5 VDC)	2.9 W			
Storage temperature	-20 °C to +85 °C ambient temperature			
Operating temperature	Hardware option	Housing	Cooling area³	Mainboard⁴
	Bare board ⁵	Not applicable	-20 °C to +85 °C	-20 °C to +88 °C
	Open housing ⁶	-20 °C to +65 °C		
Relative humidity	0% to 80% (non-condensing)			
Digital interface	MIPI CSI-2 D-PHY V1.1; 1, 2, or 4 lanes; maximum 1.051 Gbit/s per lane			
Camera controls	GenICam (GenICam for CSI-2 Access)			
	V4L2 controls (Video4Linux Access), Direct Register Access			
³ See Mounting the heat sink on page 236.				
⁴ Output by <code>DeviceTemperature</code>				
⁵ Ensure that the sensor is operated in the temperature range specified by the manufacturer. For any questions, please visit www.alliedvision.com/en/support .				
⁶ Temperature values must be observed for the housing and for the cooling area.				

Table 70: Alvium 1800 C-1240m/c specifications (sheet 2 of 2)

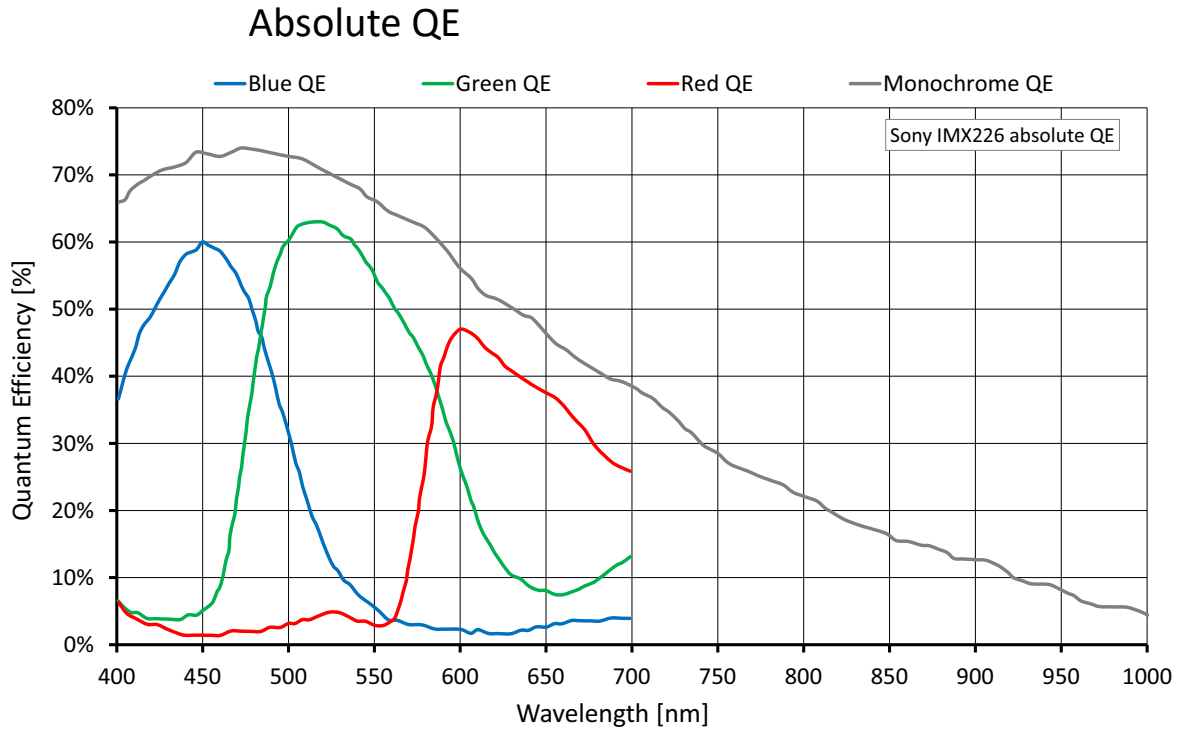

Figure 50: Alvium 1800 C-1240m/c (Sony IMX226) absolute QE

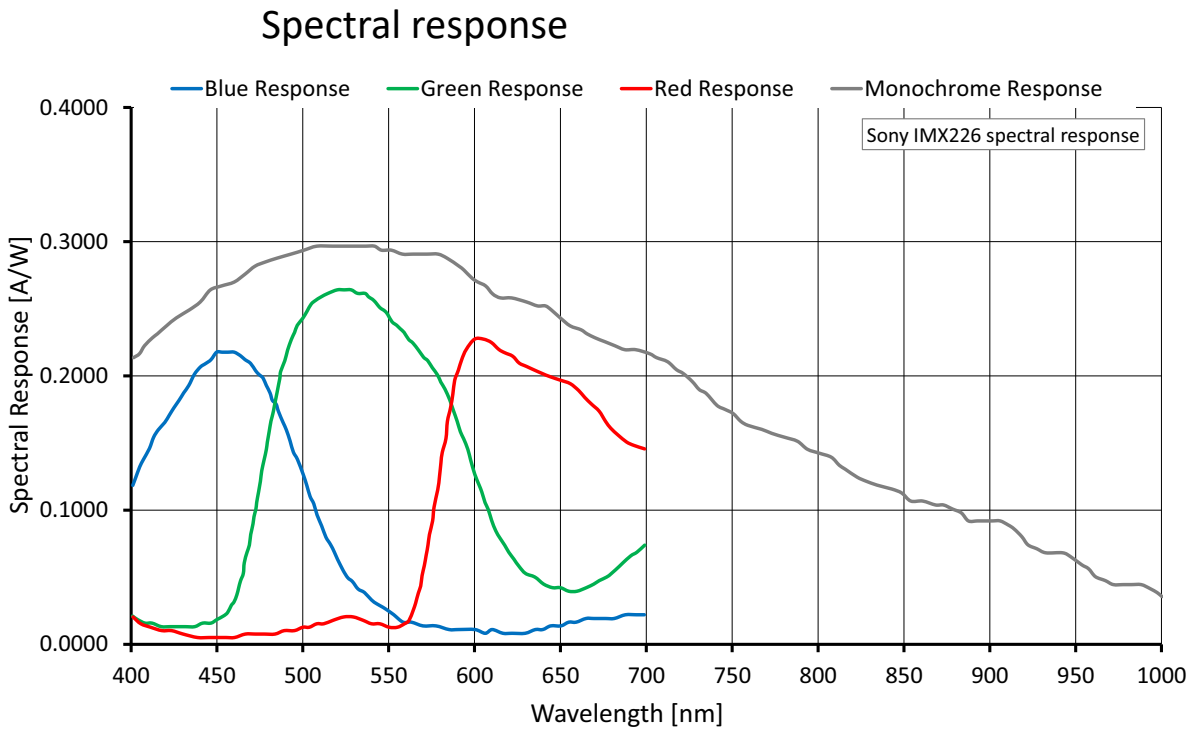

Figure 51: Alvium 1800 C-1240m/c (Sony IMX226) spectral response

Frame rates with Cropping

Values were calculated as defined in [Frame rates with ROI/Cropping](#) on page 66 and in [Operation for maximum frame rates](#) on page 68.

Frame rates at maximum bandwidth calculates for 1.051 Gbit/s per lane. To reach the maximum frame rate available for typical operation, the bandwidth for image traffic is at 4 lanes with 4.204 Gbit/s. .

Shutter mode	User mode	Available frame rates
Rolling shutter (RS)	Freerun	Values in Table 72 below are reached.
Rolling shutter (RS)	Triggered	>99% of the values for in Table 72 below are reached.
Global reset shutter (GRS)	Freerun	>99% of the values for in Table 72 below are reached.
Global reset shutter (GRS)	Triggered	

Table 71: Frame rate behavior for different configurations

Image format	Width [pixels]	Height [pixels]	ROI area [MP]	Frame rate [fps] ¹		
				4-lane	2-lane	1-lane
				4.204 Gbit/s	2.102 Gbit/s	1.051 Gbit/s
Full resolution	4024	3036	12.217	41.2	20.9	10.5
UHD 4K	3840	2160	8.294			
QSXGA	2560	2048	5.243			
WQHD	2560	1440	3.686			
QXGA	2048	1536	3.146			
Full HD	1920	1080	2.074			
UXGA	1600	1200	1.920			
WXGA+ ²	1440	904	1.302			
SXGA	1280	1024	1.311			
HD 720	1280	720	0.922			
XGA	1024	768	0.786			
SVGA	800	600	0.480			
VGA	640	480	0.307			
HVGA	480	320	0.154			
QVGA	320	240	0.077			
HQVGA	240	160	0.038			
QQVGA	160	120	0.019			
Max. × half ³	4024	1520	6.116			
Max. × min.	4024	16	0.064			
Min. × max.	16	3036	0.049			
Min. × min.	16	16	256 P			

¹ RAW8 (GREY) or RGB888 (RGB3) at 10-Bit readout
² Instead of 1,440 × 900
³ Instead of 4,024 × 1,518
 If resolutions were not available due to increments, frame rates relate to the next available resolution.

Table 72: Alvium 1800 C-1240m/c ROI frame rates



Alvium 1800 C-1242m/c

Red table border lines signal that **GeniCam for CSI-2 Access** is required.

Feature	Specification	
	1800 C-1242m (monochrome)	1800 C-1242c (color)
Sensor model	Sony IMX545	
Resolution	4128 (H) × 3008 (V); 12.4 MP	
Sensor type	CMOS	
Shutter type	Global shutter (GS)	
Sensor size	Type 1/1.1; 11.31 mm × 8.24 mm; 14 mm diagonal	
Pixel size	2.74 μm × 2.74 μm	
CRA	0 deg	
Sensor bit depth (ADC)	12-bit	
Pixel formats, GeniCam for CSI-2 Access		
Monochrome pixel formats	Mono8 (default), Mono10, Mono10p, Mono12, Mono12p	Mono8, Mono10, Mono10p, Mono12, Mono12p
YUV color pixel formats	Not applicable	YCbCr411_8_CbYYCrYY, YCbCr422_8_CbYCrY, YCbCr8_CbYCr
RGB color pixel formats	Not applicable	BGR8, RGB8 (default)
Raw color pixel formats	Not applicable	BayerRG8, BayerRG10, BayerRG10p, BayerRG12, BayerRG12p
Pixel formats, other access modes		
YUV color pixel formats	Not applicable	YUV422 8-bit (UYVY)
RGB color pixel formats	Default: RGB888 (RGB3)	
RAW pixel formats	RAW8 (GREY), RAW10 (Y10), RAW12 (Y12)	
Maximum frame rate	39 fps, using 4 lanes	
Exposure time	19 μs to 10 s (4 lanes)	
Exposure modes	Timed, TriggerControlled, TriggerWidth	
Gain	0 dB to 48 dB; 0.1 dB increments	
Digital binning ¹	Horizontal: 1 to 8 columns; Vertical: 1 to 8 rows	
Sensor binning (H × V)	2 × 2 (<i>Sum</i>)	Not applicable
Image buffer (RAM)	256 KByte	
Non-volatile memory (Flash)	1024 KByte	
GPIOs	2 programmable GPIOs As direct inputs (push-pull): 0 to 5.5 VDC As direct outputs (push-pull): 0 to 3.3 VDC at 12 mA	

¹ Digital vertical binning can be used only when digital horizontal binning is used as well.

Table 73: Alvium 1800 C-1242m/c specifications (sheet 1 of 2)

Feature	Specification			
	1800 C-1242m/c			
Power requirements	Power over MIPI CSI-2			
Power consumption (typical, at 5 VDC)	3.2 W			
Storage temperature	-20 °C to +85 °C ambient temperature			
Operating temperature	Hardware option	Housing	Cooling area²	Mainboard³
	Bare board ⁴	Not applicable	-20 °C to +85 °C	-20 °C to +85 °C
	Open housing ⁵	-20 °C to +65 °C		
Relative humidity	0% to 80% (non-condensing)			
Digital interface	MIPI CSI-2 D-PHY V1.1; 1, 2, or 4 lanes; maximum 1.051 Gbit/s per lane			
Camera controls	GenICam (GenICam for CSI-2 Access)			
	V4L2 controls (Video4Linux Access), Direct Register Access			
² See Mounting the heat sink on page 236.				
³ Output by DeviceTemperature				
⁴ Ensure that the sensor is operated in the temperature range specified by the manufacturer. For any questions, please visit www.alliedvision.com/en/support .				
⁵ Temperature values must be observed for the housing and for the cooling area.				

Table 73: Alvium 1800 C-1242m/c specifications (sheet 2 of 2)

Absolute QE

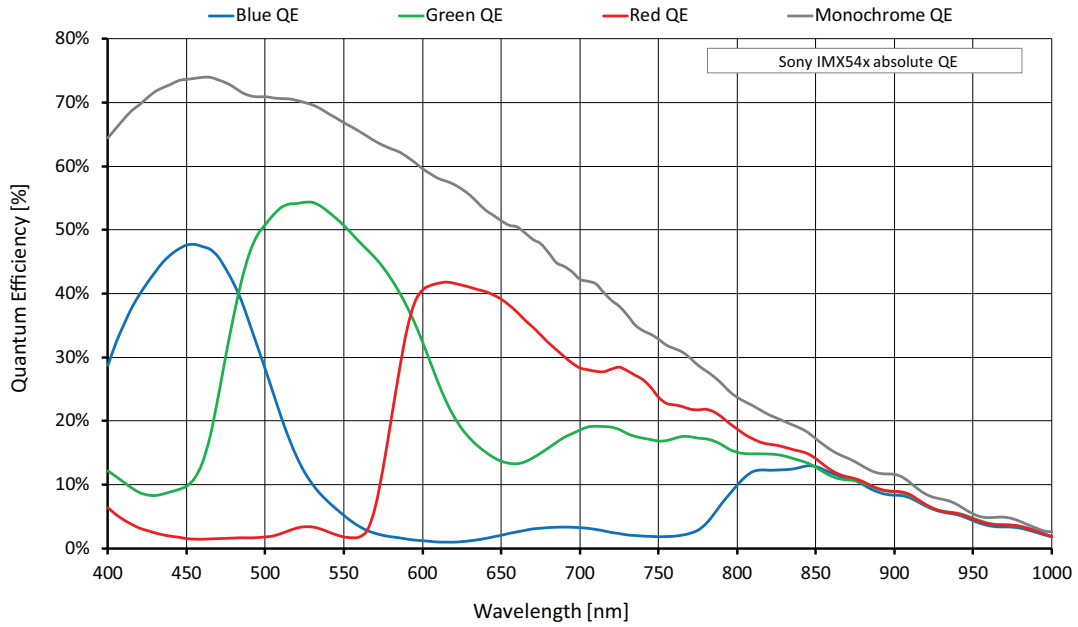

Figure 52: Alvium 1800 C-1242m/c (Sony IMX545) absolute QE

Spectral response

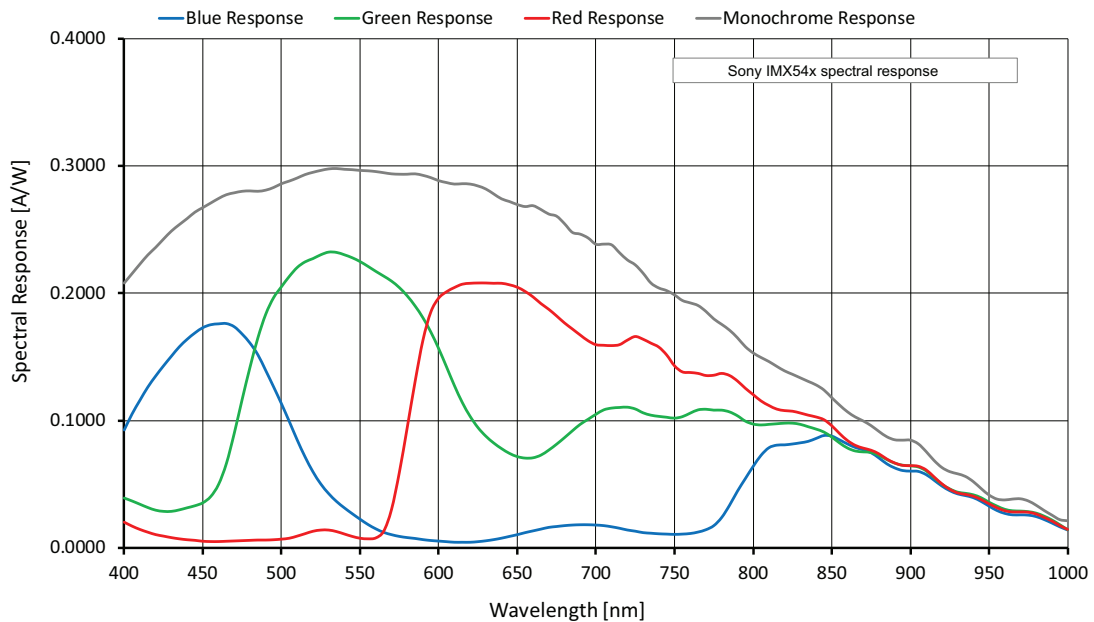

Figure 53: Alvium 1800 C-1242m/c (Sony IMX545) spectral response

Frame rates with Cropping

Values were calculated as defined in [Frame rates with ROI/Cropping](#) on page 66 and in [Operation for maximum frame rates](#) on page 68.

Frame rates at maximum bandwidth calculates for 1.051 Gbit/s per lane. To reach the maximum frame rate available for typical operation, the bandwidth for image traffic is at 4 lanes with 4.204 Gbit/s.

Image format	Width [pixels]	Height [pixels]	ROI area [MP]	Frame rate [fps] ¹		
				4-lane	2-lane	1-lane
				4.204 Gbit/s	2.102 Gbit/s	1.051 Gbit/s
Full resolution	4128	3008	12.417	39.8	20.0	10.0
UHD 4K	3840	2160	8.294	55.8	29.4	14.8
QSXGA	2560	2048	5.243	59.0	46.4	23.3
WQHD	2560	1440	3.686	81.4	64.1	32.2
QXGA	2048	1536	3.146	77.0	75.5	38.0
Full HD	1920	1080	2.074	105.5		55.5
UXGA	1600	1200	1.920	96.4		60.8
WXGA+ ²	1440	904	1.302	123.6		86.4
SXGA	1280	1024	1.311	111.1		87.4
HD 720	1280	720	0.922	149.9		118.0
XGA	1024	768	0.786	142.5		139.6
SVGA	800	600	0.480	175.2		
VGA	640	480	0.307	209.1		
HVGA	480	320	0.154	281.7		
QVGA	320	240	0.077	340.4		
HQVGA	240	160	0.038	430.0		
QQVGA	160	120	0.019	495.1		
Max. × half	4128	1504	6.209	75.4	38.2	19.2
Max. × min.	4128	16	0.066	645.3	363.2	193.8
Min. × max.	16	3008	0.048	41.4		
Min. × min.	16	16	256 P	817.0		

¹ RAW8 (GREY) or RGB888 (RGB3) at 12-Bit readout
² Instead of 1,440 × 900
 If resolutions were not available due to increments, frame rates relate to the next available resolution.

Table 74: Alvium 1800 C-1242m/c ROI frame rates



Alvium 1800 C-1620m/c

Red table border lines signal that **GeniCam for CSI-2 Access** is required.

Feature	Specification	
	1800 C-1620m (monochrome)	1800 C-1620c (color)
Sensor model	Sony IMX542	
Resolution	5328 (H) × 3040 (V); 16.2 MP	
Sensor type	CMOS	
Shutter type	Global shutter (GS)	
Sensor size	Type 1.1; 14.6 mm × 8.33 mm; 16.8 mm diagonal	
Pixel size	2.74 μm × 2.74 μm	
CRA	0 deg	
Sensor bit depth (ADC)	12-bit	
	Pixel formats, GeniCam for CSI-2 Access	
Monochrome pixel formats	Mono8 (default), Mono10, Mono10p, Mono12, Mono12p	Mono8, Mono10, Mono10p, Mono12, Mono12p
YUV color pixel formats	Not applicable	YCbCr411_8_CbYYCrYY, YCbCr422_8_CbYCrY, YCbCr8_CbYCr
RGB color pixel formats	Not applicable	BGR8, RGB8 (default)
Raw color pixel formats	Not applicable	BayerRG8, BayerRG10, BayerRG10p, BayerRG12, BayerRG12p
	Pixel formats, other access modes	
YUV color pixel formats	Not applicable	YUV422 8-bit (UYVY)
RGB color pixel formats	Default: RGB888 (RGB3)	
RAW pixel formats	RAW8 (GREY), RAW10 (Y10), RAW12 (Y12)	
Maximum frame rate	30 fps, using 4 lanes	
Exposure time	23 μs to 10 s (4 lanes)	
Exposure modes	Timed, TriggerControlled, TriggerWidth	
Gain	0 dB to 48 dB; 0.1 dB increments	
Digital binning ¹	Horizontal: 1 to 8 columns; Vertical: 1 to 8 rows	
Sensor binning (H × V)	2 × 2 (<i>Sum</i>)	Not applicable
Image buffer (RAM)	256 KByte	
Non-volatile memory (Flash)	1024 KByte	
GPIOs	2 programmable GPIOs As direct inputs (push-pull): 0 to 5.5 VDC As direct outputs (push-pull): 0 to 3.3 VDC at 12 mA	
¹ Digital vertical binning can be used only when digital horizontal binning is used as well.		

Table 75: Alvium 1800 C-1620m/c specifications (sheet 1 of 2)

Feature	Specification			
	1800 C-1620m/c			
Power requirements	Power over MIPI CSI-2			
Power consumption (typical, at 5 VDC)	3.8 W			
Storage temperature	-20 °C to +85 °C ambient temperature			
Operating temperature	Hardware option	Housing	Cooling area²	Mainboard³
	Bare board ⁴	Not applicable	-20 °C to +85 °C	-20 °C to +85 °C
	Open housing ⁵	-20 °C to +65 °C		
Relative humidity	0% to 80% (non-condensing)			
Digital interface	MIPI CSI-2 D-PHY V1.1; 1, 2, or 4 lanes; maximum 1.051 Gbit/s per lane			
Camera controls	GenICam (GenICam for CSI-2 Access)			
	V4L2 controls (Video4Linux Access), Direct Register Access			
² See Mounting the heat sink on page 236.				
³ Output by DeviceTemperature				
⁴ Ensure that the sensor is operated in the temperature range specified by the manufacturer. For any questions, please visit www.alliedvision.com/en/support .				
⁵ Temperature values must be observed for the housing and for the cooling area.				

Table 75: Alvium 1800 C-1620m/c specifications (sheet 2 of 2)

Absolute QE

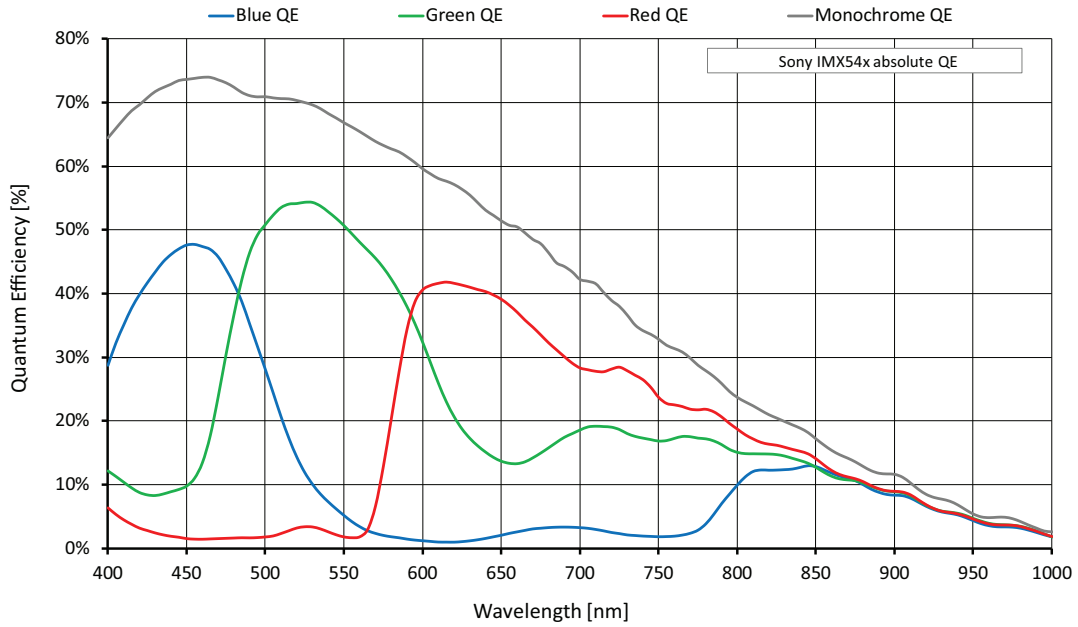

Figure 54: Alvium 1800 C-1620m/c (Sony IMX542) absolute QE

Spectral response

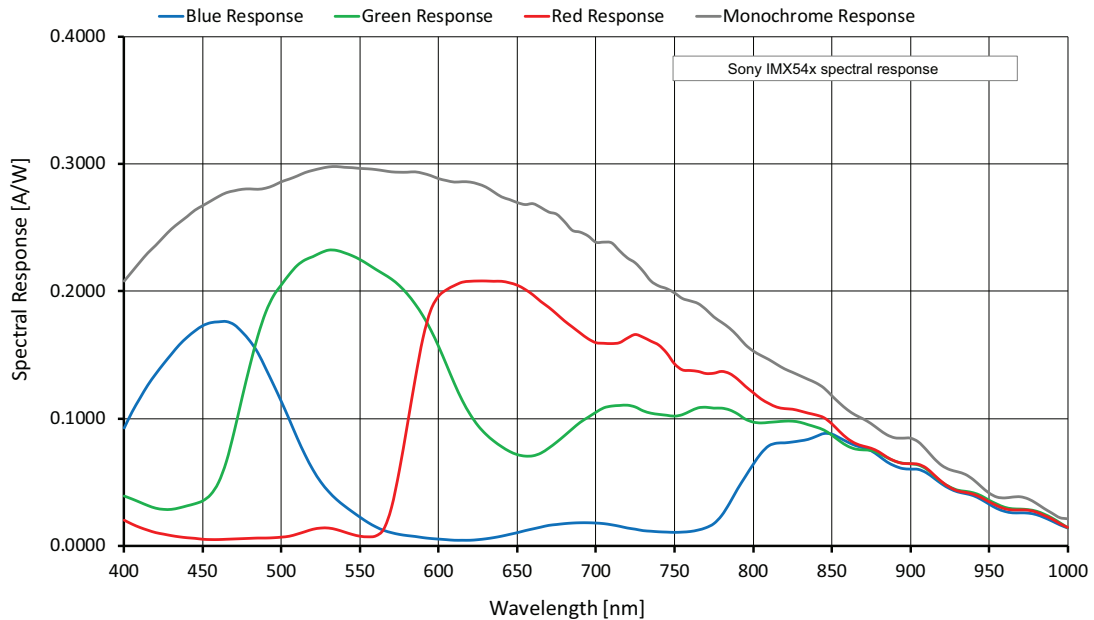

Figure 55: Alvium 1800 C-1620m/c (Sony IMX542) spectral response

Frame rates with Cropping

Values were calculated as defined in [Frame rates with ROI/Cropping](#) on page 66 and in [Operation for maximum frame rates](#) on page 68.

Frame rates at maximum bandwidth calculates for 1.051 Gbit/s per lane. To reach the maximum frame rate available for typical operation, the bandwidth for image traffic is at 4 lanes with 4.204 Gbit/s.

Image format	Width [pixels]	Height [pixels]	ROI area [MP]	Frame rate [fps] ¹		
				4-lane	2-lane	1-lane
				4.204 Gbit/s	2.102 Gbit/s	1.051 Gbit/s
Full resolution	5328	3040	16.148	30.8	15.5	7.8
UHD 4K	3840	2160	8.294	44.6	29.6	14.9
QXGA	2560	2048	5.243	47.1	46.8	23.5
WQHD	2560	1440	3.686	65.2	64.9	32.7
QXGA	2048	1536	3.146	61.7		38.4
Full HD	1920	1080	2.074	84.9		56.4
UXGA	1600	1200	1.920	77.4		61.8
WXGA+ ²	1440	904	1.302	99.7		88.0
SXGA	1280	1024	1.311	89.4		88.9
HD 720	1280	720	0.922	121.4		120.8
XGA	1024	768	0.786	115.3		
SVGA	800	600	0.480	142.2		
VGA	640	480	0.307	171.0		
HVGA	480	320	0.154	232.7		
QVGA	320	240	0.077	284.0		
HQVGA	240	160	0.038	364.4		
QQVGA	160	120	0.019	424.3		
Max. × half	5312	1520	8.074	58.7	29.7	15.0
Max. × min.	5312	16	0.085	557.8	318.5	171.6
Min. × max.	16	3040	0.049	32.6		
Min. × min.	16	16	256 P	741.9		

¹ RAW8 (GREY) or GB888 (RGB3) at 12-Bit readout
² Instead of 1,440 × 900
 If resolutions were not available due to increments, frame rates relate to the next available resolution.

Table 76: Alvium 1800 C-1620m/c ROI frame rates



Alvium 1800 C-2040m/c

Red table border lines signal that **GeniCam for CSI-2 Access** is required.

Feature	Specification	
	1800 C-2040m (monochrome)	1800 C-2040c (color)
Sensor model	Sony IMX541	
Resolution	4512 (H) × 4512 (V); 20.4 MP	
Sensor type	CMOS	
Shutter type	Global shutter (GS)	
Sensor size	Type 1.1; 12.36 mm × 12.36 mm; 17.5 mm diagonal	
Pixel size	2.74 μm × 2.74 μm	
CRA	0 deg	
Sensor bit depth (ADC)	12-bit	
	Pixel formats, GeniCam for CSI-2 Access	
Monochrome pixel formats	Mono8 (default), Mono10, Mono10p, Mono12, Mono12p	Mono8, Mono10, Mono10p, Mono12, Mono12p
YUV color pixel formats	Not applicable	YCbCr411_8_CbYYCrYY, YCbCr422_8_CbYCrY, YCbCr8_CbYCr
RGB color pixel formats	Not applicable	BGR8, RGB8 (default)
Raw color pixel formats	Not applicable	BayerRG8, BayerRG10, BayerRG10p, BayerRG12, BayerRG12p
	Pixel formats, other access modes	
YUV color pixel formats	Not applicable	YUV422 8-bit (UYVY)
RGB color pixel formats	Default: RGB888 (RGB3)	
RAW pixel formats	RAW8 (GREY), RAW10 (Y10), RAW12 (Y12)	
Maximum frame rate	24 fps, using 4 lanes	
Exposure time	20 μs to 10 s (4 lanes)	
Exposure modes	Timed, TriggerControlled, TriggerWidth	
Gain	0 dB to 48 dB; 0.1 dB increments	
Digital binning ¹	Horizontal: 1 to 8 columns; Vertical: 1 to 8 rows	
Sensor binning (H × V)	2 × 2 (<i>Sum</i>)	Not applicable
Image buffer (RAM)	256 KByte	
Non-volatile memory (Flash)	1024 KByte	
GPIOs	2 programmable GPIOs As direct inputs (push-pull): 0 to 5.5 VDC As direct outputs (push-pull): 0 to 3.3 VDC at 12 mA	

¹ Digital vertical binning can be used only when digital horizontal binning is used as well.

Table 77: Alvium 1800 C-2040m/c specifications (sheet 1 of 2)

Feature	Specification			
	1800 C-2040m/c			
Power requirements	Power over MIPI CSI-2			
Power consumption (typical, at 5 VDC)	3.7 W			
Storage temperature	-20 °C to +85 °C ambient temperature			
Operating temperature	Hardware option	Housing	Cooling area²	Mainboard³
	Bare board ⁴	Not applicable	-20 °C to +85 °C	-20 °C to +85 °C
	Open housing ⁵	-20 °C to +65 °C		
Relative humidity	0% to 80% (non-condensing)			
Digital interface	MIPI CSI-2 D-PHY V1.1; 1, 2, or 4 lanes; maximum 1.051 Gbit/s per lane			
Camera controls	GenICam (GenICam for CSI-2 Access) V4L2 controls (Video4Linux Access), Direct Register Access			
² See Mounting the heat sink on page 236. ³ Output by DeviceTemperature ⁴ Ensure that the sensor is operated in the temperature range specified by the manufacturer. For any questions, please visit www.alliedvision.com/en/support . ⁵ Temperature values must be observed for the housing and for the cooling area.				

Table 77: Alvium 1800 C-2040m/c specifications (sheet 2 of 2)

Absolute QE

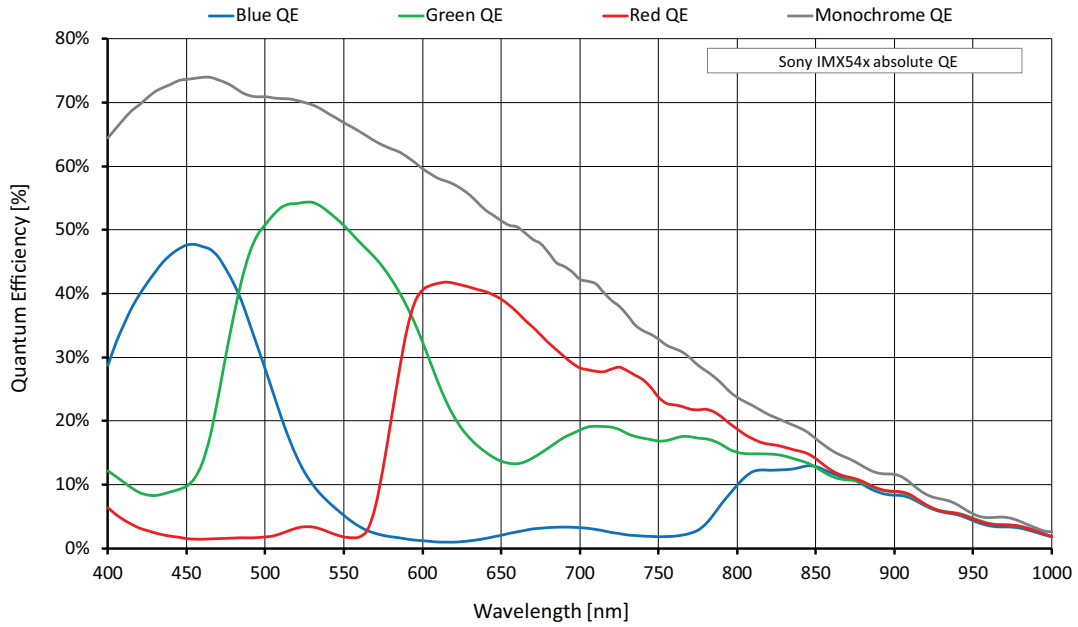

Figure 56: Alvium 1800 C-2040m/c (Sony IMX541) absolute QE

Spectral response

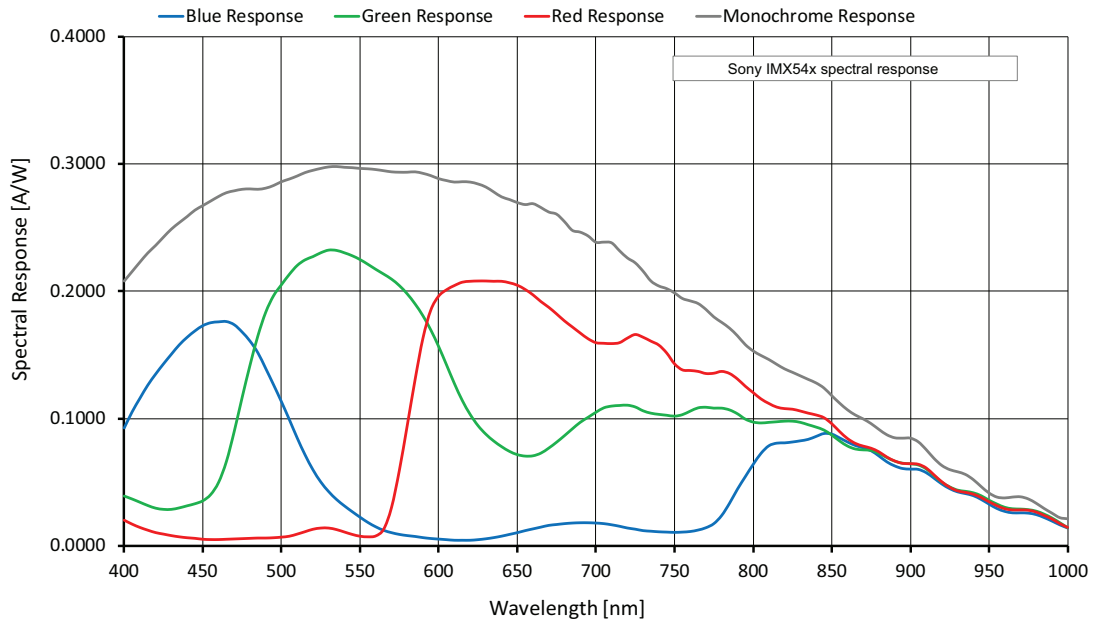

Figure 57: Alvium 1800 C-2040m/c (Sony IMX541) spectral response

Frame rates with Cropping

Values were calculated as defined in [Frame rates with ROI/Cropping](#) on page 66 and in [Operation for maximum frame rates](#) on page 68.

Frame rates at maximum bandwidth calculates for 1.051 Gbit/s per lane. To reach the maximum frame rate available for typical operation, the bandwidth for image traffic is at 4 lanes with 4.204 Gbit/s.

Image format	Width [pixels]	Height [pixels]	ROI area [MP]	Frame rate [fps] ¹		
				4-lane	2-lane	1-lane
				4.204 Gbit/s	2.102 Gbit/s	1.051 Gbit/s
Full resolution	4512	4512	20.358	24.8	12.5	6.2
HXGA	4096	3072	12.583	37.2	19.9	10.0
UHD 4K	3840	2160	8.294	52.0	29.6	14.9
QSXGA	2560	2048	5.243	54.9	46.8	23.5
WQHD	2560	1440	3.686	76.0	64.8	32.6
QXGA	2048	1536	3.146	71.9		38.4
Full HD	1920	1080	2.074	98.8		56.4
UXGA	1600	1200	1.920	90.2		61.7
WXGA+ ²	1440	904	1.302	116.1		87.9
SXGA	1280	1024	1.311	104.1		88.7
HD 720	1280	720	0.922	141.3		120.5
XGA	1024	768	0.786	134.2		
SVGA	800	600	0.480	165.5		
VGA	640	480	0.307	198.9		
HVGA	480	320	0.154	270.2		
QVGA	320	240	0.077	329.3		
HQVGA	240	160	0.038	421.4		
QQVGA	160	120	0.019	489.9		
Max. × half	4512	2256	10.179	47.9	24.2	12.1
Max. × min.	4512	16	0.072	648.1	370.6	199.2
Min. × max.	16	4512	0.072	25.9		
Min. × min.	16	16	256 P	848.8		

¹ RAW8 (GREY) or RGB888 (RGB3) at 12-Bit readout
² Instead of 1,440 × 900
 If resolutions were not available due to increments, frame rates relate to the next available resolution.

Table 78: Alvium 1800 C-2040m/c ROI frame rates



Alvium 1800 C-2050m/c

Red table border lines signal that **GeniCam for CSI-2 Access** is required.

Feature	Specification	
	1800 C-2050m (monochrome)	1800 C-2050c (color)
Sensor model	Sony IMX183	
Resolution	5376 (H) × 3672 (V); 19.7 MP	
Sensor type	CMOS	
Shutter type	Rolling shutter (RS), Global reset shutter (GRS)	
Sensor size	Type 1; 13.1 mm × 8.8 mm; 15.86 mm diagonal	
Pixel size	2.4 μm × 2.4 μm	
CRA	3 deg	
ADC bit depth	10-bit	
Pixel formats, GeniCam for CSI-2 Access		
Monochrome pixel formats	Mono8 (default), Mono10, Mono10p, Mono12, Mono12p	Mono8, Mono10, Mono10p, Mono12, Mono12p
YUV color pixel formats	Not applicable	YCbCr411_8_CbYYCrYY, YCbCr422_8_CbYCrY, YCbCr8_CbYCr
RGB color pixel formats	Not applicable	BGR8, RGB8 (default)
Raw color pixel formats	Not applicable	BayerRG8, BayerRG10, BayerRG10p, BayerRG12, BayerRG12p
Pixel formats, other access modes		
YUV color pixel formats	Not applicable	YUV422 8-bit (UYVY)
RGB color pixel formats	Default: RGB888 (RGB3)	
RAW pixel formats	RAW8 (GREY), RAW10 (Y10)	
Maximum frame rate	25 fps ¹ , using 4 lanes	
Exposure time	15 μs to 10 s (4 lanes)	
Exposure modes	Timed	
Gain	0 dB to 27 dB; 0.1 dB increments	
Digital binning ²	Horizontal: 1 to 8 columns; Vertical: 1 to 8 rows	
Image buffer (RAM)	256 KByte	
Non-volatile memory (Flash)	1024 KByte	
GPIOs	2 programmable GPIOs As direct inputs (push-pull): 0 to 5.5 VDC As direct outputs (push-pull): 0 to 3.3 VDC at 12 mA	

¹ In triggered mode: ~25 fps

² Digital vertical binning can be used only when digital horizontal binning is used as well.

Table 79: Alvium 1800 C-2050m/c specifications (sheet 1 of 2)

Feature	Specification			
	1800 C-2050m/c			
Power requirements	Power over MIPI CSI-2			
Power consumption (typical, at 5 VDC)	2.9 W			
Storage temperature	-20 °C to +85 °C ambient temperature			
Operating temperature	Hardware option	Housing	Cooling area³	Mainboard⁴
	Bare board ⁵	Not applicable	-20 °C to +85 °C	-20 °C to +88 °C
	Open housing ⁶	-20 °C to +65 °C		
Relative humidity	0% to 80% (non-condensing)			
Digital interface	MIPI CSI-2 D-PHY V1.1; 1, 2, or 4 lanes; maximum 1.051 Gbit/s per lane			
Camera controls	GenICam (GenICam for CSI-2 Access)			
	V4L2 controls (Video4Linux Access), Direct Register Access			
³ See Mounting the heat sink on page 236.				
⁴ Output by <code>DeviceTemperature</code>				
⁵ Ensure that the sensor is operated in the temperature range specified by the manufacturer. For any questions, please visit www.alliedvision.com/en/support .				
⁶ Temperature values must be observed for the housing and for the cooling area.				

Table 79: Alvium 1800 C-2050m/c specifications (sheet 2 of 2)

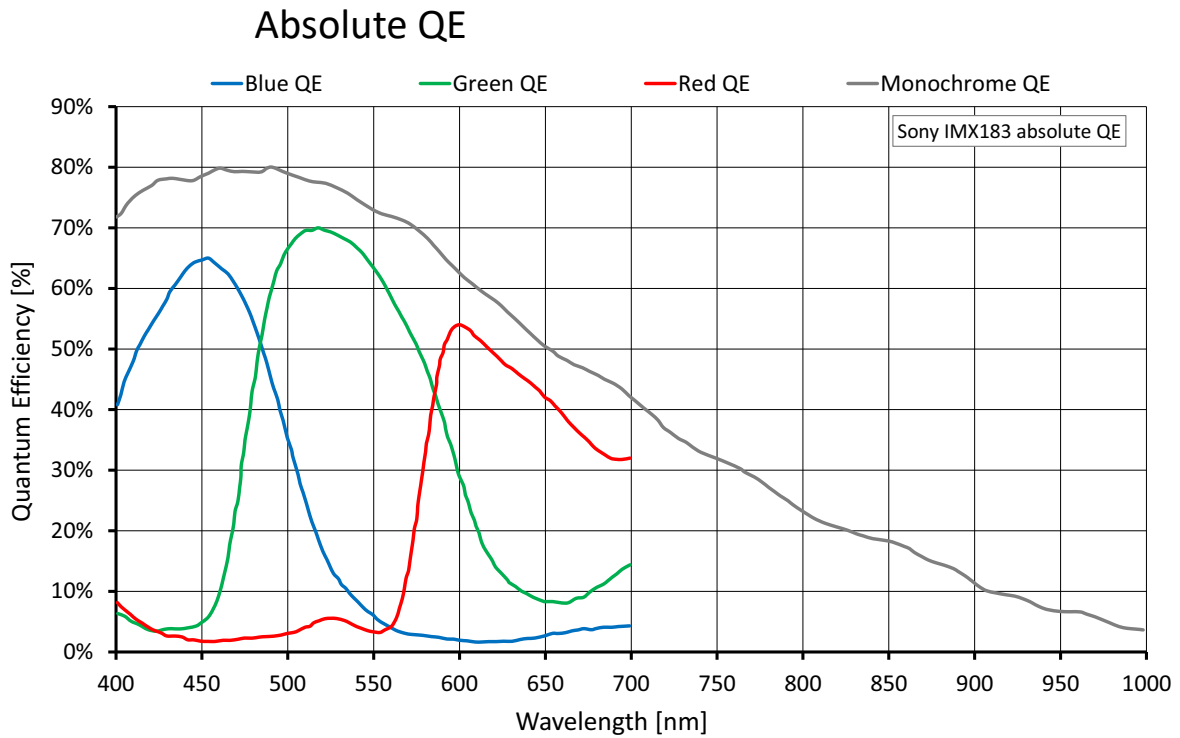

Figure 58: Alvium 1800 C-2050m/c (Sony IMX183) absolute QE

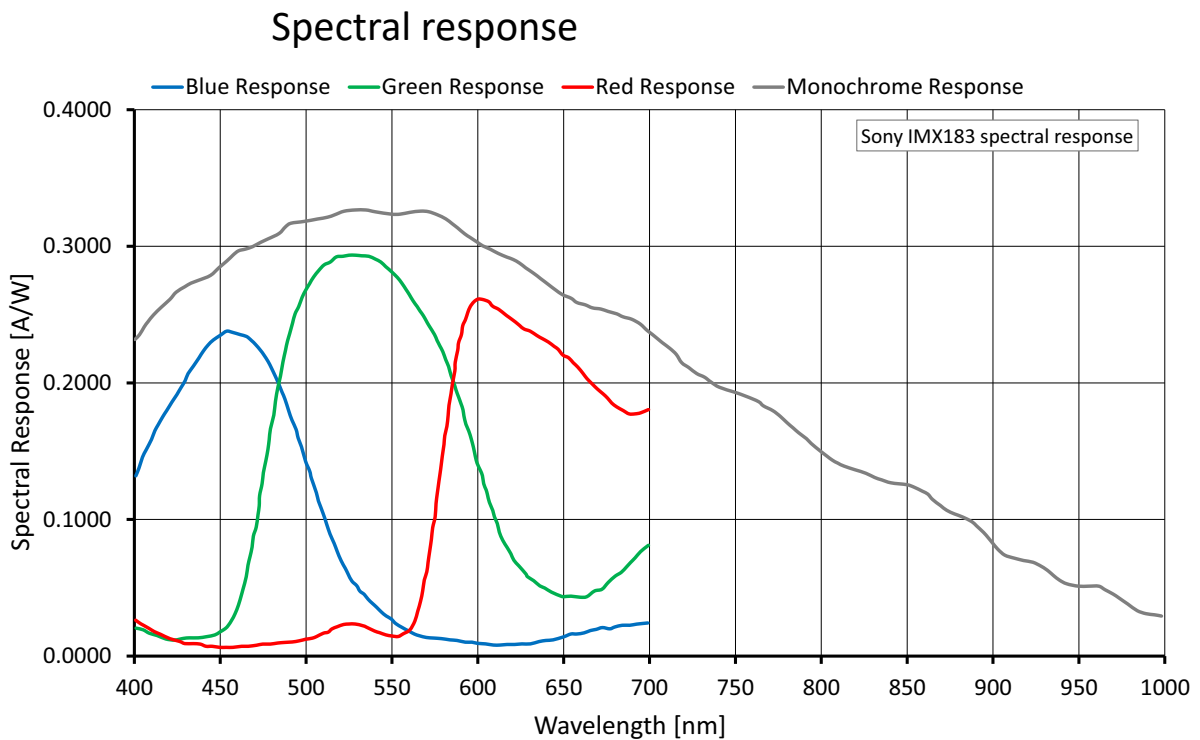

Figure 59: Alvium 1800 C-2050m/c (Sony IMX183) spectral response

Frame rates with Cropping

Values were calculated as defined in [Frame rates with ROI/Cropping](#) on page 66 and in [Operation for maximum frame rates](#) on page 68.

Frame rates at maximum bandwidth calculates for 1.051 Gbit/s per lane. To reach the maximum frame rate available for typical operation, the bandwidth for image traffic is at 4 lanes with 4.204 Gbit/s.

Shutter mode	User mode	Available frame rates
Rolling shutter (RS)	Freerun	Values in Table 81 below are reached.
Rolling shutter (RS)	Triggered	>99% of the values for in Table 81 below are reached.
Global reset shutter (GRS)	Freerun	>99% of the values for in Table 81 below are reached.
Global reset shutter (GRS)	Triggered	>99% of the values for in Table 81 below are reached.

Table 80: Frame rate behavior for different configurations

Image format	Width [pixels]	Height [pixels]	ROI area [MP]	Frame rate [fps] ¹		
				4-lane	2-lane	1-lane
				4.204 Gbit/s	2.102 Gbit/s	1.051 Gbit/s
Full resolution	5376	3672	19.741	25.1	12.6	6.3
HXGA	4096	3072	12.583	29.8	15.0	7.5
UHD 4K	3840	2160	8.294	41.7	21.1	10.6
QSXGA	2560	2048	5.243	43.9	22.2	11.2
WQHD	2560	1440	3.686	48.3	24.5	12.3
QXGA	2048	1536	3.146			
Full HD	1920	1080	2.074			
UXGA	1600	1200	1.920			
WXGA+ ²	1440	904	1.302			
SXGA	1280	1024	1.311			
...			
QVGA	320	240	0.077			
HQVGA	240	160	0.038			
QQVGA	160	120	0.019			
Max. × half ³	5376	1840	9.892	25.1	12.6	6.3
Max. × min.	5376	16	0.086			
Min. × max.	16	3672	0.059			
Min. × min.	16	16	256 P	48.3	24.5	12.3

¹ Mono8 / RAW8 (GREY) or Bayer...8⁽²⁾ / RGB888 (RGB3) at 10-Bit readout

² The three dots... represent the colors of a Bayer pixel format, such as in BayerRG8.

² Instead of 1,440 × 900

³ Instead of 5,376 × 1,836

If resolutions were not available due to increments, frame rates relate to the next available resolution.

Table 81: Alvium 1800 C-2050m/c ROI frame rates



Alvium 1800 C-2460m/c

Red table border lines signal that **GeniCam for CSI-2 Access** is required.

Feature	Specification	
	1800 C-2460m (monochrome)	1800 C-2460c (color)
Sensor model	Sony IMX540	
Resolution	5328 (H) × 4608 (V); 24.6 MP	
Sensor type	CMOS	
Shutter type	Global shutter (GS)	
Sensor size	Type 1.2; 14.60 mm × 12.63 mm; 19.3 mm diagonal	
Pixel size	2.74 μm × 2.74 μm	
CRA	0 deg	
Sensor bit depth (ADC)	12-bit	
Pixel formats, GeniCam for CSI-2 Access		
Monochrome pixel formats	Mono8 (default), Mono10, Mono10p, Mono12, Mono12p	Mono8, Mono10, Mono10p, Mono12, Mono12p
YUV color pixel formats	Not applicable	YCbCr411_8_CbYYCrYY, YCbCr422_8_CbYCrY, YCbCr8_CbYCr
RGB color pixel formats	Not applicable	BGR8, RGB8 (default)
Raw color pixel formats	Not applicable	BayerRG8, BayerRG10, BayerRG10p, BayerRG12, BayerRG12p
Pixel formats, other access modes		
YUV color pixel formats	Not applicable	YUV422 8-bit (UYVY)
RGB color pixel formats	Default: RGB888 (RGB3)	
RAW pixel formats	RAW8 (GREY), RAW10 (Y10), RAW12 (Y12)	
Maximum frame rate	20 fps, using 4 lanes	
Exposure time	23 μs to 10 s (4 lanes)	
Exposure modes	Timed, TriggerControlled, TriggerWidth	
Gain	0 dB to 48 dB; 0.1 dB increments	
Digital binning ¹	Horizontal: 1 to 8 columns; Vertical: 1 to 8 rows	
Sensor binning (H × V)	2 × 2 (<i>Sum</i>)	Not applicable
Image buffer (RAM)	256 KByte	
Non-volatile memory (Flash)	1024 KByte	
GPIOs	2 programmable GPIOs As direct inputs (push-pull): 0 to 5.5 VDC As direct outputs (push-pull): 0 to 3.3 VDC at 12 mA	

¹ Digital vertical binning can be used only when digital horizontal binning is used as well.

Table 82: Alvium 1800 C-2460m/c specifications (sheet 1 of 2)

Feature	Specification			
	1800 C-2460m/c			
Power requirements	Power over MIPI CSI-2			
Power consumption (typical, at 5 VDC)	3.8 W			
Storage temperature	-20 °C to +85 °C ambient temperature			
Operating temperature	Hardware option	Housing	Cooling area²	Mainboard³
	Bare board ⁴	Not applicable	-20 °C to +85 °C	-20 °C to +85 °C
	Open housing ⁵	-20 °C to +65 °C		
Relative humidity	0% to 80% (non-condensing)			
Digital interface	MIPI CSI-2 D-PHY V1.1; 1, 2, or 4 lanes; maximum 1.051 Gbit/s per lane			
Camera controls	GenICam (GenICam for CSI-2 Access) V4L2 controls (Video4Linux Access), Direct Register Access			
² See Mounting the heat sink on page 236. ³ Output by DeviceTemperature ⁴ Ensure that the sensor is operated in the temperature range specified by the manufacturer. For any questions, please visit www.alliedvision.com/en/support . ⁵ Temperature values must be observed for the housing and for the cooling area.				

Table 82: Alvium 1800 C-2460m/c specifications (sheet 2 of 2)

Absolute QE

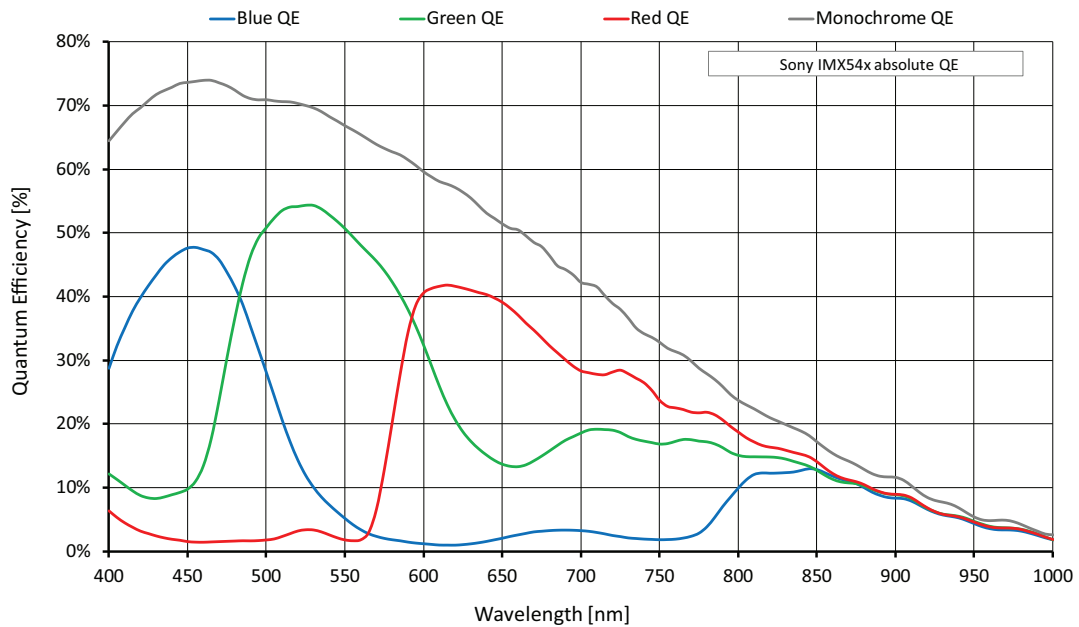

Figure 60: Alvium 1800 C-2460m/c (Sony IMX540) absolute QE

Spectral response

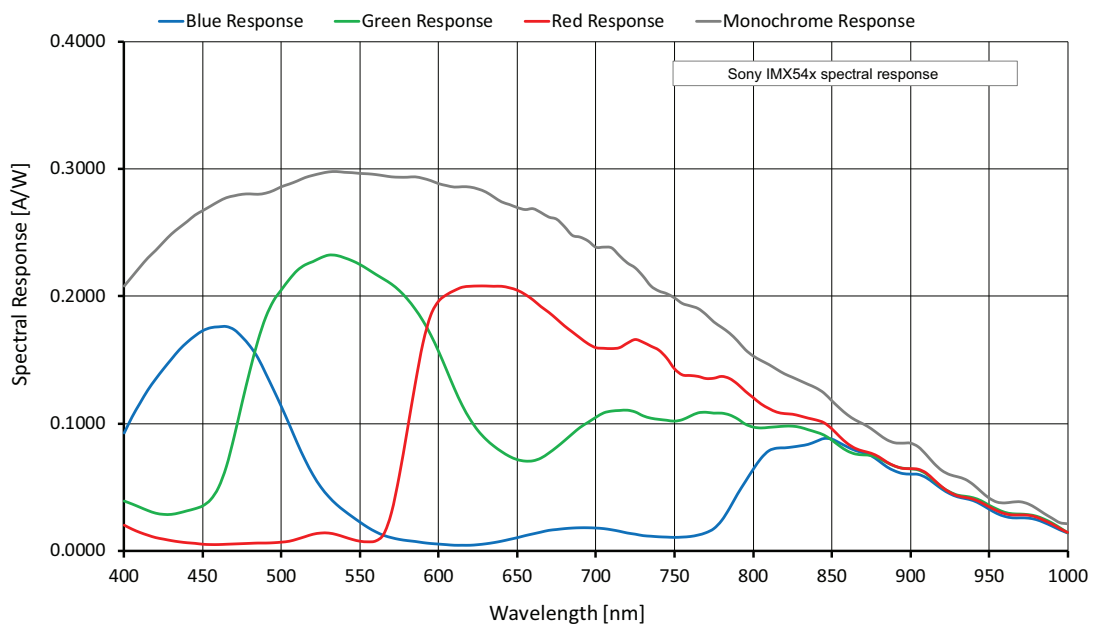

Figure 61: Alvium 1800 C-2460m/c (Sony IMX540) spectral response

Frame rates with Cropping

Values were calculated as defined in [Frame rates with ROI/Cropping](#) on page 66 and in [Operation for maximum frame rates](#) on page 68.

Frame rates at maximum bandwidth calculates for 1.051 Gbit/s per lane. To reach the maximum frame rate available for typical operation, the bandwidth for image traffic is at 4 lanes with 4.204 Gbit/s.

Image format	Width [pixels]	Height [pixels]	ROI area [MP]	Frame rate [fps] ¹		
				4-lane	2-lane	1-lane
				4.204 Gbit/s	2.102 Gbit/s	1.051 Gbit/s
Full resolution	5328	4608	24.551	20.5	10.3	5.2
HSXGA	5120	4096	20.972	24.0	12.1	6.0
HXGA	4096	3072	12.583	31.9	19.9	10.0
UHD 4K	3840	2160	8.294	44.6	29.6	14.9
QSXGA	2560	2048	5.243	47.1	46.8	23.5
WQHD	2560	1440	3.686	65.2	64.9	32.7
QXGA	2048	1536	3.146	61.7		38.4
Full HD	1920	1080	2.074	84.9		56.4
UXGA	1600	1200	1.920	77.4		61.8
WXGA+ ²	1440	904	1.302	99.7		88.0
SXGA	1280	1024	1.311	89.4		88.9
HD 720	1280	720	0.922	121.4		120.8
XGA	1024	768	0.786	115.3		
SVGA	800	600	0.480	142.2		
VGA	640	480	0.307	171.0		
HVGA	480	320	0.154	232.7		
QVGA	320	240	0.077	284.0		
HQVGA	240	160	0.038	364.4		
QQVGA	160	120	0.019	424.3		
Max. × half	5328	2304	12.276	39.8	20.1	10.1
Max. × min.	5328	16	0.085	554.8	317.6	171.1
Min. × max.	16	4608	0.074	21.8		
Min. × min.	16	16	256 P	741.9		

¹ RAW8 (GREY) or RGB888 (RGB3) at 12-Bit readout
² Instead of 1,440 × 900
 If resolutions were not available due to increments, frame rates relate to the next available resolution.

Table 83: Alvium 1800 C-2460m/c ROI frame rates

White balance default

Alvium color cameras are balanced for neutral color reproduction with an illumination of 5000 °K (warm daylight). [Table 84](#) shows default values for the red and blue channel by model.

For different illuminations, use auto white balance or adapt the color channel values manually. See the descriptions in [Access modes](#) on page 226 for details.



Monochrome and VSWIR models

White balance default does not apply to monochrome and VSWIR models.

Alvium model	Sensor model	Red channel value	Blue channel value
1500 C-050c	ON Semiconductor PYTHON 480	1.930	1.500
1500 C-120c	ON Semiconductor AR0135CS	1.760	1.650
1500 C-210c	ON Semiconductor AR0521SR	2.120	1.520
1500 C-500c	ON Semiconductor AR0521SR	2.120	1.520
1500 C-501c NIR	ON Semiconductor AR0522	1.500	1.770
1800 C-040c	Sony IMX287	2.360	2.030
1800 C-052c	Sony IMX426	2.290	2.000
1800 C-158c	Sony IMX273	2.355	2.100
1800 C-203c	Sony IMX422	2.290	2.000
1800 C-234c	Sony IMX249	2.580	1.810
1800 C-235c	Sony IMX174	2.580	1.810
1800 C-240c	Sony IMX392	2.355	2.100
1800 C-291c	Sony IMX421	2.290	2.000
1800 C-319c	Sony IMX265	2.355	2.100
1800 C-500c	ON Semiconductor AR0521SR	2.120	1.520
1800 C-507c	Sony IMX264	2.355	2.100
1800 C-508c	Sony IMX250	2.355	2.100
1800 C-510c	Sony IMX548	2.870	2.000
1800 C-511c	Sony IMX547	2.870	2.000
1800 C-811c	Sony IMX546	2.870	2.000
1800 C-895c	Sony IMX267	2.355	2.100
1800 C-1236c	Sony IMX304	2.355	2.100
1800 C-1240c	Sony IMX226	2.620	1.810
1800 C-1242c	Sony IMX545	2.870	2.000

Table 84: Alvium default values for color channels (sheet 1 of 2)

Alvium model	Sensor model	Red channel value	Blue channel value
1800 C-1620c	Sony IMX542	2.870	2.000
1800 C-2040c	Sony IMX541	2.870	2.000
1800 C-2050c	Sony IMX183	2.660	1.830
1800 C-2460c	Sony IMX540	2.870	2.000

Table 84: Alvium default values for color channels (sheet 2 of 2)

Standard Alvium: Dimensions and mass

Bare board cameras	Specification
Dimensions (L × W × H)	[Model specific] × 26 mm × 26 mm
Mass [g]	10 g

Table 85: Standard Alvium bare board dimensions and mass

Open housing cameras	C-Mount	CS-Mount	S-Mount
Flange focal distance, optical	17.526 mm	12.526 mm	12.63 mm
Thread	1"-32tpi UNS-2B	1"-32tpi UNS-2B	M12 mm × 0.5 mm
Maximum protrusion ¹	13.6 mm	8.6 mm	11.0 mm
Body dimensions (L × W × H) in [mm]	26 × 29 × 29	21 × 29 × 29	20 × 29 × 29
Mass	40 g	40 g	40 g

¹For details, see [Maximum protrusion for front mounts](#).

Table 86: Standard Alvium housing dimensions and mass

Standard Alvium: Technical drawings

Standard Alvium CSI-2 cameras are available with the following housing options:

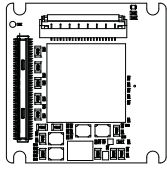
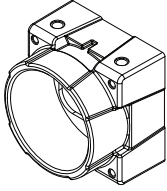
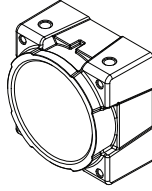
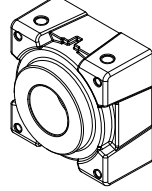
				
Option	Bare Board	Open Housing C-Mount	Open Housing CS-Mount	Open Housing S-Mount
Page	190	192	193	194

Bare Board (standard Alvium)

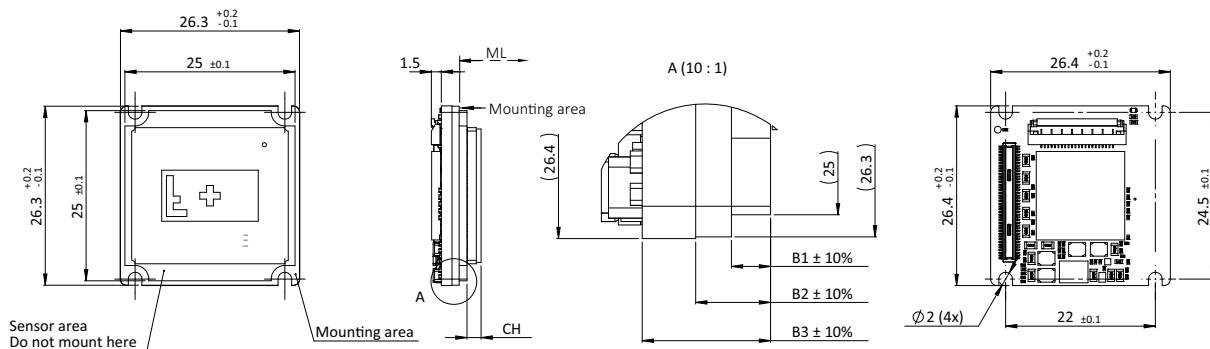

Figure 62: Bare Board (standard Alvium) dimensions

Dimensions that are common between different models are shown in [Figure 62](#), model specific dimensions are listed in [Table 87](#). **Mechanical length (ML)** defines the mechanical distance from the mounting area to the lens mount front flange, without optical filter. **Components height (CH)** relates to the electronic components with maximum height, sometimes the sensor.



Mechanical length for S-Mount and CS-Mount

Mechanical length for other mounts is:

- CS-Mount: [C-Mount value] – 5 mm
- S-Mount: depending on your design.

Camera model	ML: Mechanical length* for C-Mount	CH: Components height, incl. the sensor	B1: Board thickness	B2: Board thickness	B3: Board thickness
Alvium 1500 C-050m/c	19.604 mm	1.40 mm	1.75 mm	3.00 mm	4.55 mm
Alvium 1500 C-120m/c	19.689 mm	1.44 mm	1.25 mm	2.40 mm	3.95 mm
Alvium 1500 C-210m/c	19.739 mm	1.67 mm	1.30 mm	2.40 mm	3.95 mm
Alvium 1500 C-500m/c	19.739 mm	1.67 mm	1.30 mm	2.40 mm	3.95 mm
Alvium 1500 C-501m/c NIR	19.739 mm	1.67 mm	1.30 mm	2.40 mm	3.95 mm
Alvium 1800 C-030 VSWIR	19.613 mm	2.87 mm	1.25 mm	2.20 mm	3.75 mm
Alvium 1800 C-040m/c	19.879 mm	2.27 mm	1.20 mm	2.20 mm	3.75 mm
Alvium 1800 C-052m/c	19.713 mm	2.87 mm	1.10 mm	2.20 mm	3.75 mm
Alvium 1800 C-130 VSWIR	19.613 mm	2.87 mm	1.25 mm	2.20 mm	3.75 mm
Alvium 1800 C-158m/c	19.879 mm	2.27 mm	1.20 mm	2.20 mm	3.75 mm
Alvium 1800 C-203m/c	19.713 mm	2.87 mm	1.10 mm	2.20 mm	3.75 mm
Alvium 1800 C-234m/c	19.713 mm	2.87 mm	1.10 mm	2.20 mm	3.75 mm
Alvium 1800 C-235m/c	19.713 mm	2.87 mm	1.10 mm	2.20 mm	3.75 mm
Alvium 1800 C-240m/c	19.929 mm	2.27 mm	1.25 mm	2.20 mm	3.75 mm
Alvium 1800 C-291m/c	19.713 mm	2.87 mm	1.10 mm	2.20 mm	3.75 mm
Alvium 1800 C-319m/c	19.929 mm	2.27 mm	1.25 mm	2.20 mm	3.75 mm
Alvium 1800 C-500m/c	19.739 mm	1.67 mm	1.30 mm	2.40 mm	3.95 mm
Alvium 1800 C-507m/c	19.929 mm	2.27 mm	1.25 mm	2.20 mm	3.75 mm
Alvium 1800 C-508m/c	19.929 mm	2.27 mm	1.25 mm	2.20 mm	3.75 mm
Alvium 1800 C-510m/c	19.713 mm	2.20 mm	1.10 mm	2.20 mm	3.75 mm
Alvium 1800 C-511m/c	19.613 mm	2.88 mm	1.00 mm	2.20 mm	3.75 mm
Alvium 1800 C-811m/c	19.613 mm	2.88 mm	1.00 mm	2.20 mm	3.75 mm
Alvium 1800 C-812 UV	19.610 mm	2.88 mm	1.00 mm	2.20 mm	3.75 mm
Alvium 1800 C-895m/c	19.829 mm	2.27 mm	1.15 mm	2.20 mm	3.75 mm
Alvium 1800 C-1236m/c	19.829 mm	2.27 mm	1.15 mm	2.20 mm	3.75 mm
Alvium 1800 C-1240m/c	19.763 mm	2.20 mm	1.15 mm	2.20 mm	3.75 mm
Alvium 1800 C-1242m/c	19.613 mm	2.88 mm	1.00 mm	2.20 mm	3.75 mm
Alvium 1800 C-1620m/c	19.613 mm	2.88 mm	1.00 mm	2.20 mm	3.75 mm
Alvium 1800 C-2040m/c	19.613 mm	2.88 mm	1.00 mm	2.20 mm	3.75 mm
Alvium 1800 C-2050m/c	19.663 mm	2.87 mm	1.05 mm	2.20 mm	3.75 mm
Alvium 1800 C-2460m/c	19.613 mm	2.88 mm	1.00 mm	2.20 mm	3.75 mm
*Theoretical values					

Table 87: Bare Board (standard Alvium and Alvium Flex) model specific dimensions and nominal values

Open Housing C-Mount (standard Alvium)

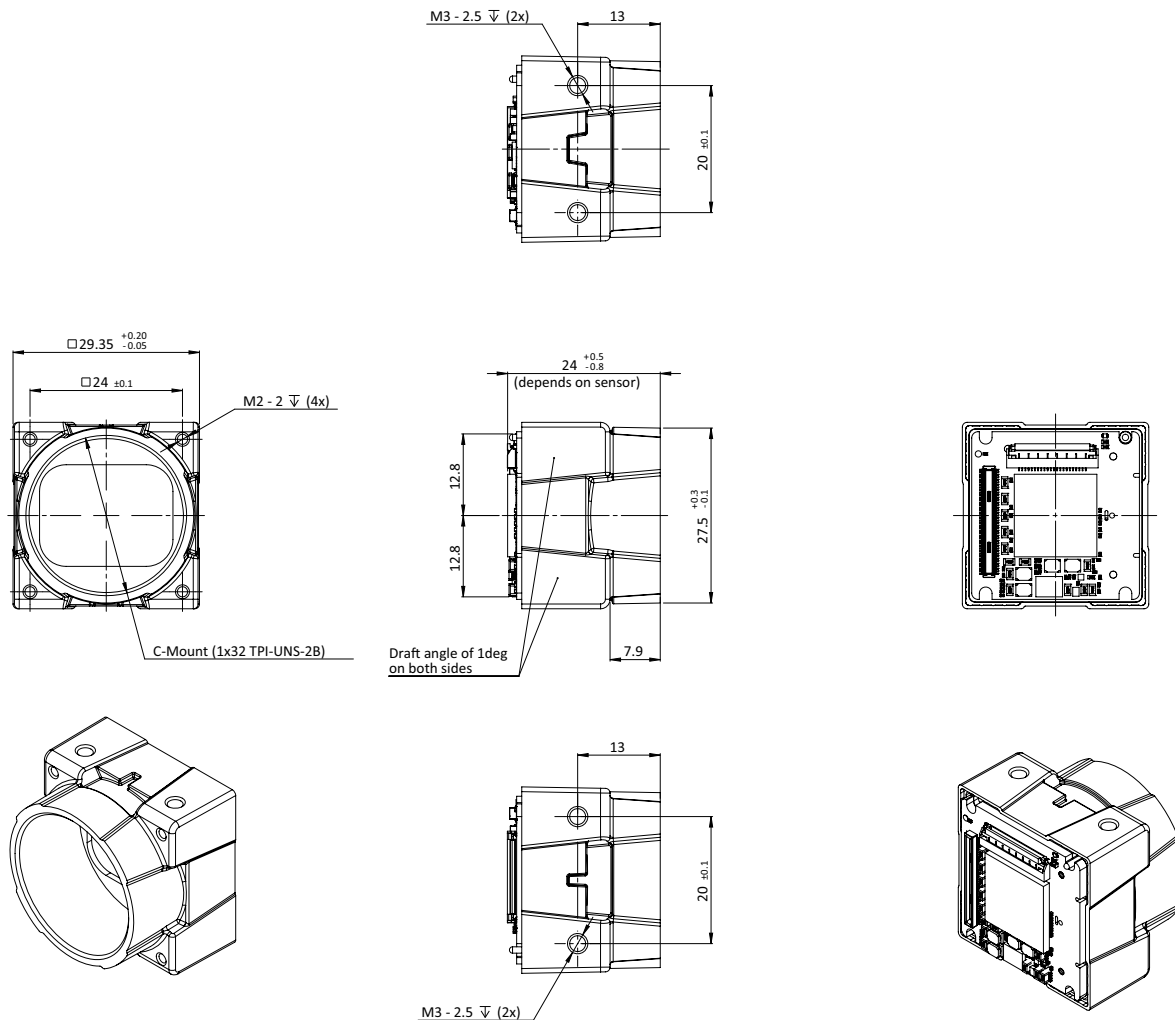

Figure 63: Open Housing C-Mount (standard Alvium) dimensions

Open Housing CS-Mount (standard Alvium)

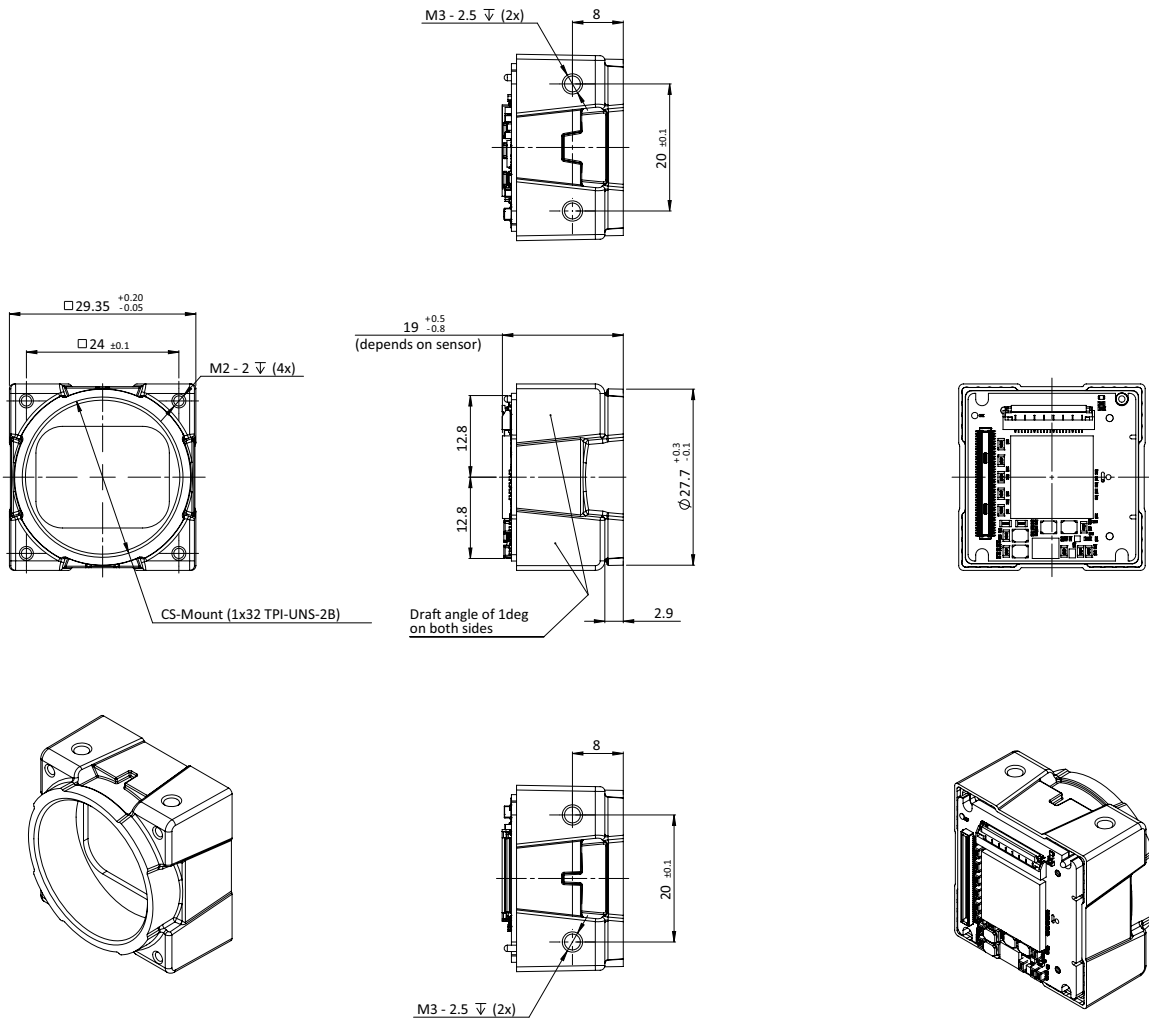

Figure 64: Open Housing CS-Mount (standard Alvium) dimensions

Open Housing S-Mount (standard Alvium)

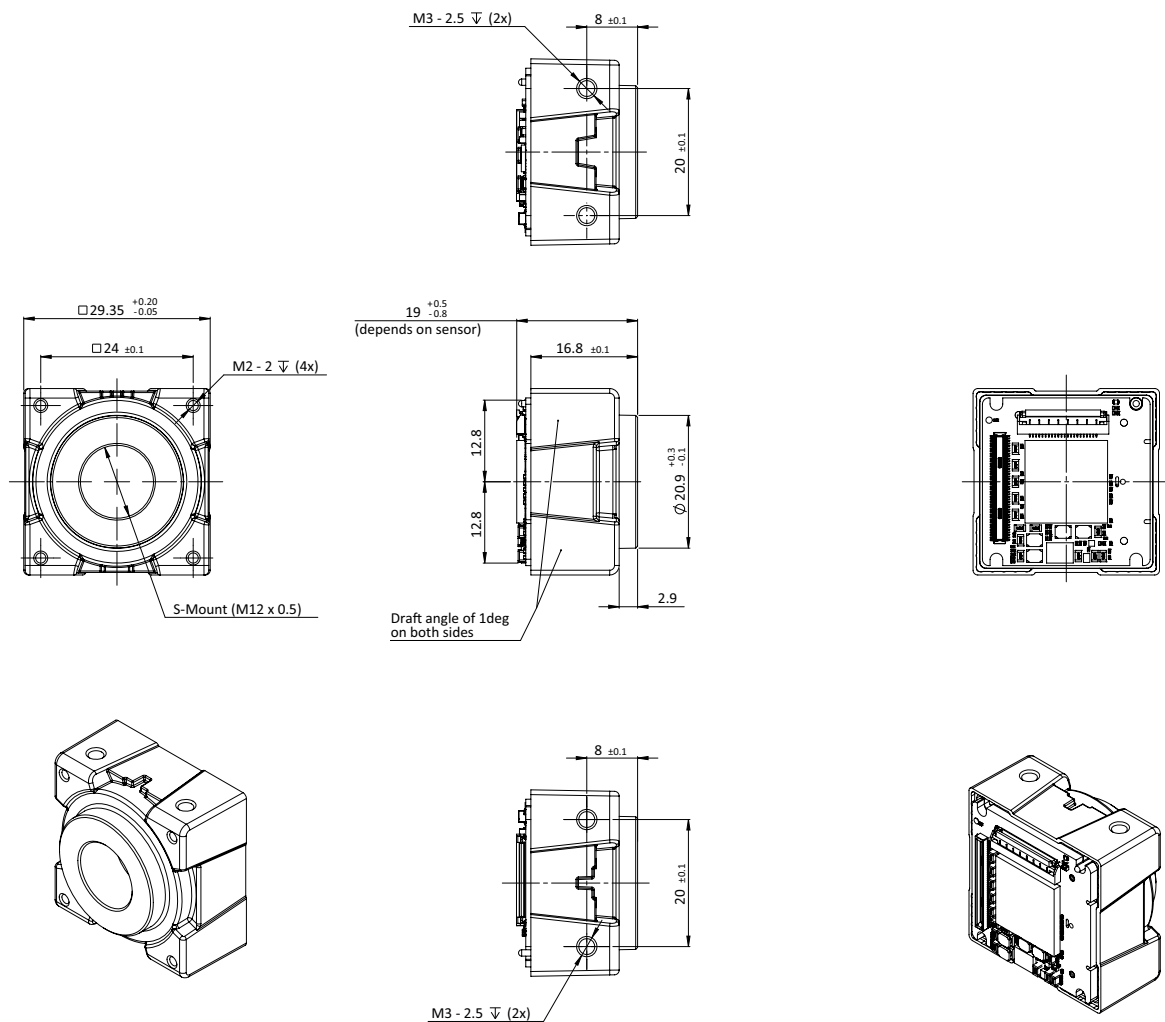

Figure 65: Open Housing S-Mount (standard Alvium) dimensions

Alvium Flex: Dimensions and mass

Bare board cameras	Specification
Dimensions (L × W × H)	[Model specific] × 26 mm × 26 mm
Mass [g]	10 g

Table 88: Bare board dimensions and mass (Alvium Flex)

Open housing cameras	C-Mount	CS-Mount	S-Mount
Flange focal distance, optical	17.526 mm	12.526 mm	12.63 mm
Thread	1"-32tpi UNS-2B	1"-32tpi UNS-2B	M12 mm × 0.5 mm
Maximum protrusion ¹	13.6 mm	8.6 mm	11.0 mm
Body dimensions (L × W × H) in [mm]	25 × 29 × 29	20 × 29 × 29	20 × 29 × 29
Mass	40 g	40 g	40 g

¹For details, see [Maximum protrusion for front mounts](#).

Table 89: Housing dimensions and mass (Alvium Flex)

Alvium Flex: Technical drawings

Alvium CSI-2 Flex cameras are available with the following housing options:

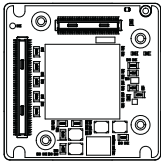
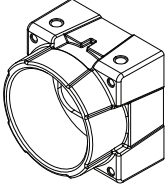
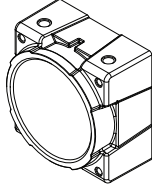
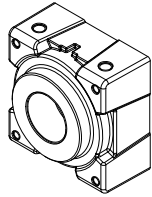
				
Option	Bare Board	Open Housing C-Mount	Open Housing CS-Mount	Open Housing S-Mount
Page	196	197	198	199

Bare Board (Alvium Flex)

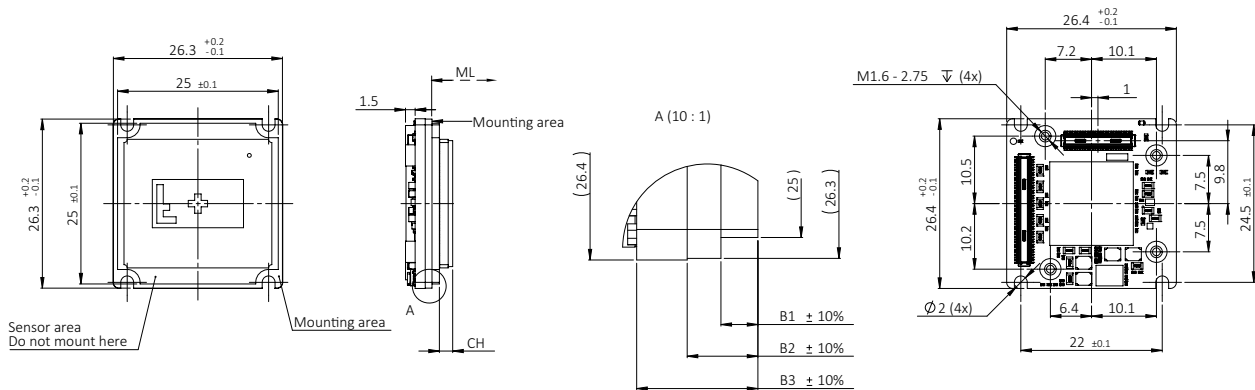

Figure 66: Bare Board (Alvium Flex) dimensions

Dimensions that are common between different models are shown in [Figure 66](#), model specific dimensions are listed in [Table 87](#). **Mechanical length** (ML) defines the mechanical distance from the mounting area to the lens mount front flange, without optical filter. **Components height** (CH) relates to the electronic components with maximum height, sometimes the sensor.

Open Housing C-Mount (Alvium Flex)

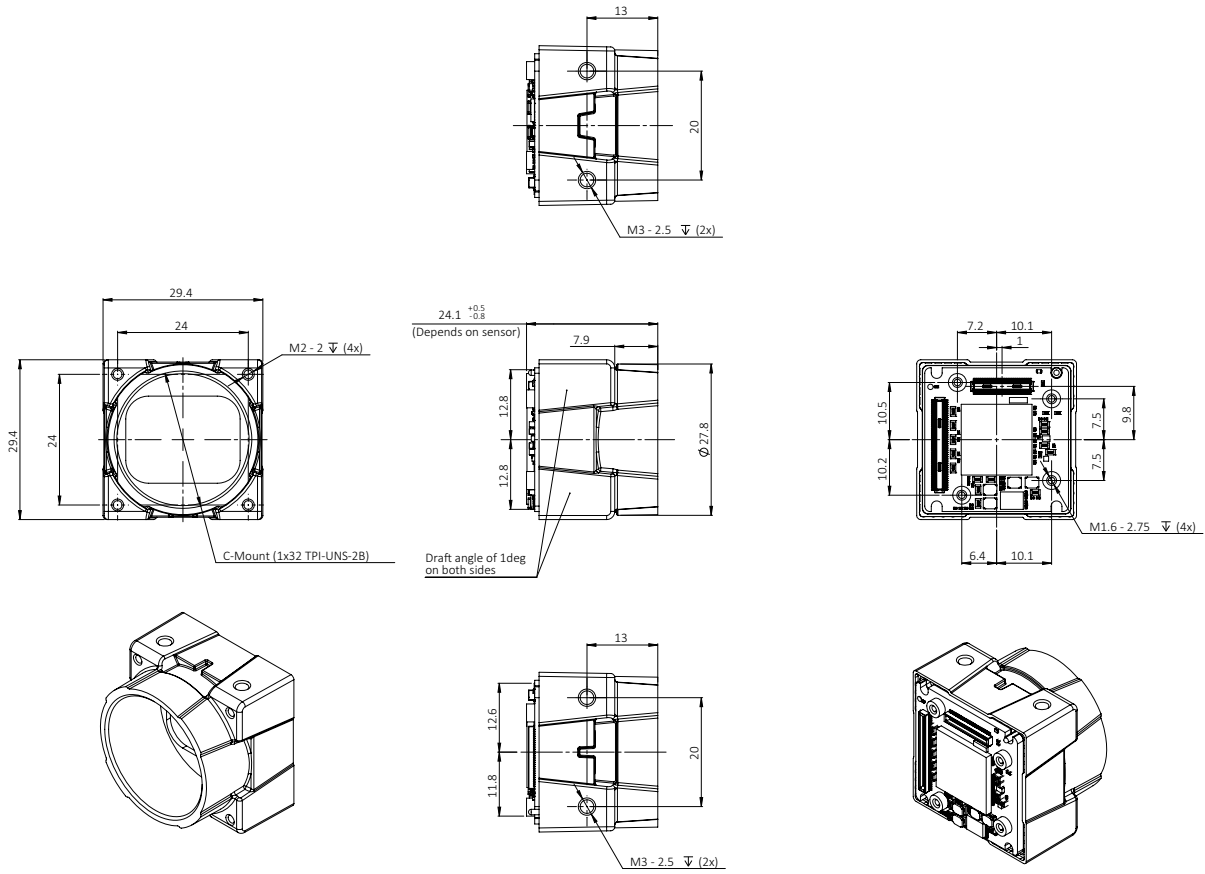

Figure 67: Open Housing C-Mount (Alvium Flex) dimensions

Open Housing CS-Mount (Alvium Flex)

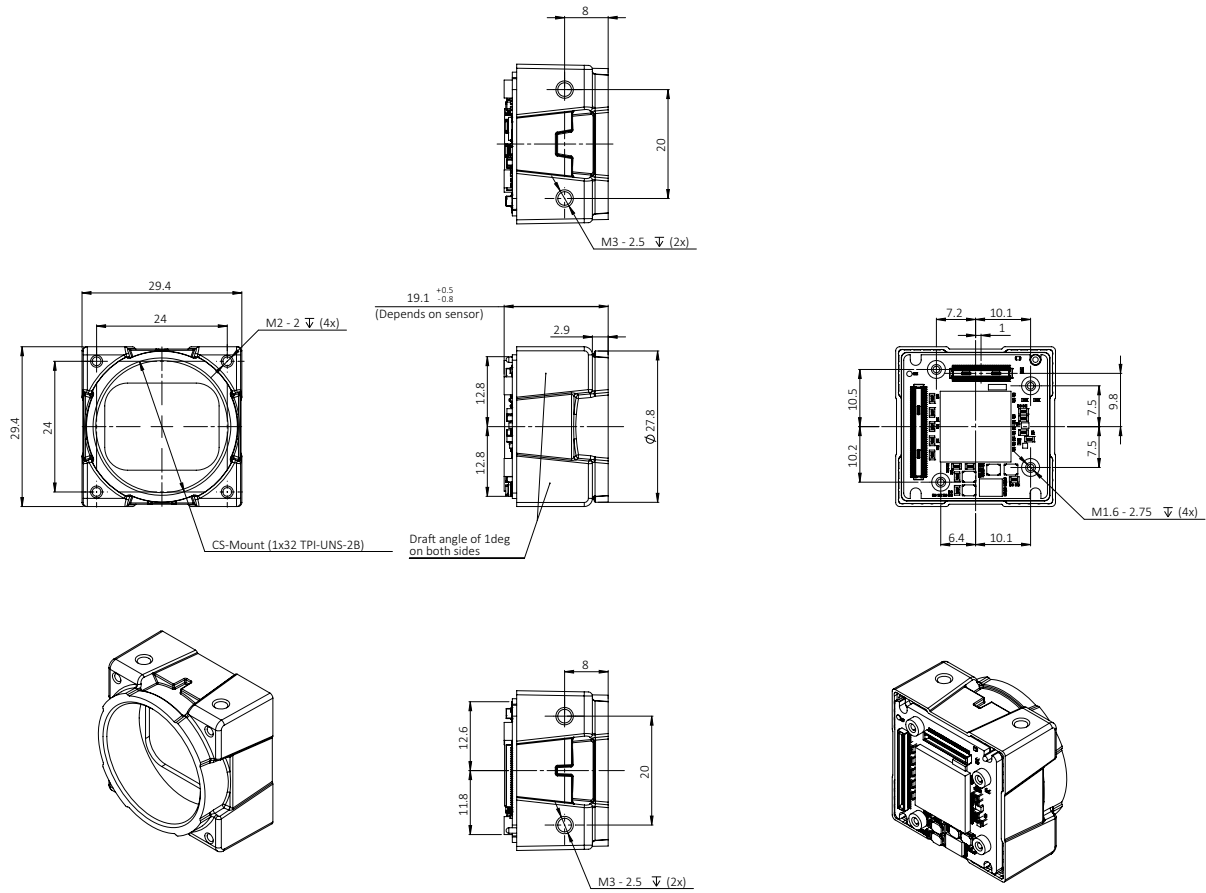

Figure 68: Open Housing CS-Mount (Alvium Flex) dimensions

Open Housing S-Mount (Alvium Flex)

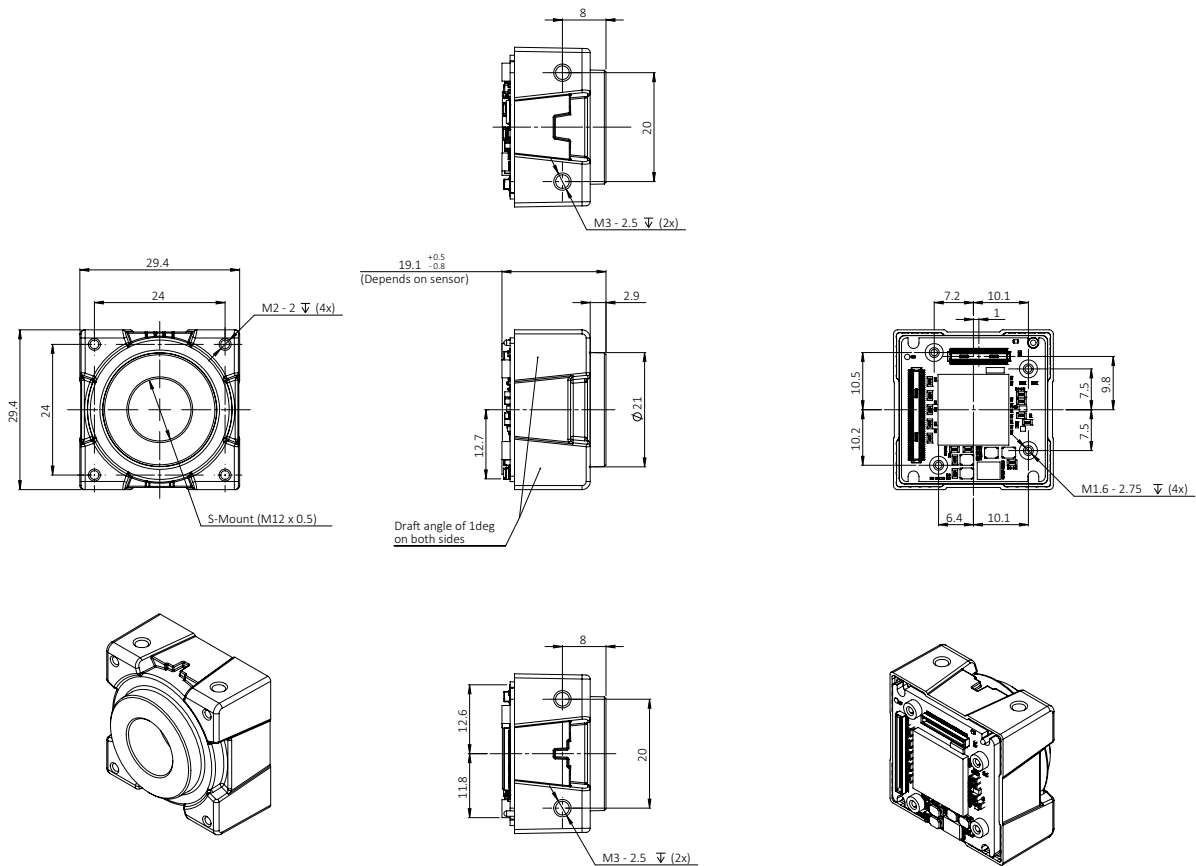

Figure 69: Open Housing S-Mount (Alvium Flex) dimensions

Alvium Frame: Dimensions and mass

Frame cameras	Frame
Flange focal distance, optical	3.576 mm
Front hole diameter	24.5 mm
Maximum protrusion ¹	1.5 mm
Body dimensions (L × W × H)	10 mm × 29 mm × 29 mm
Mass	15 g

¹For details, see [Maximum protrusion for front mounts](#).

Table 90: Housing dimensions and mass (Alvium Frame)

Alvium Frame: Technical drawings

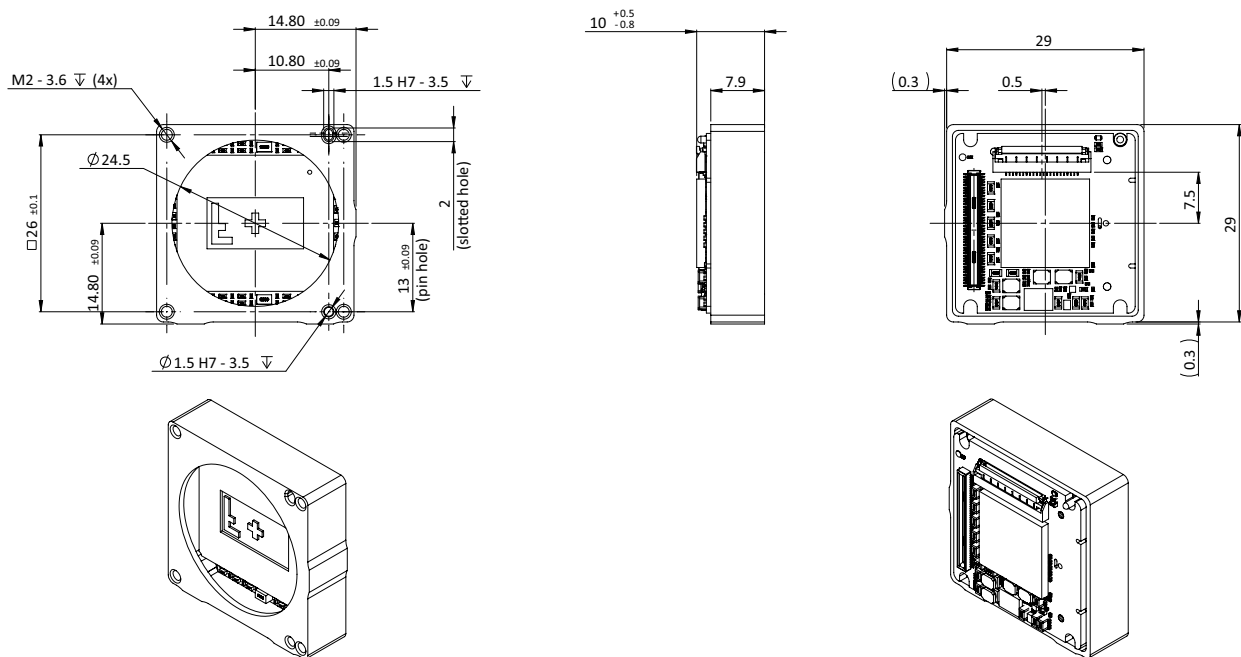

Figure 70: Alvium Frame dimensions

Alvium Frame Flex: Dimensions and mass

Frame cameras	Frame
Flange focal distance, optical	3.576 mm
Front hole diameter	24.5 mm
Maximum protrusion ¹	1.5 mm
Body dimensions (L × W × H)	10.1 × 29 mm × 29 mm
Mass	15 g

¹For details, see [Maximum protrusion for front mounts](#).

Table 91: Housing dimensions and mass (Alvium Frame Flex)

Alvium Frame Flex: Technical drawings

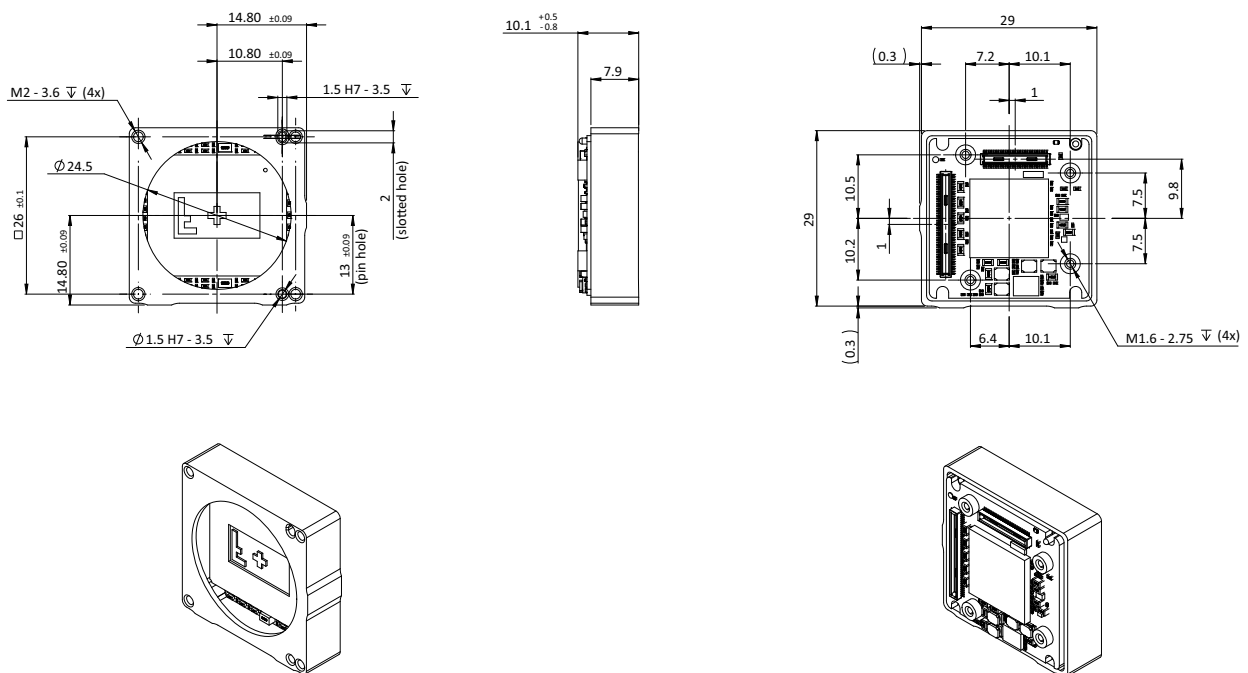

Figure 71: Alvium Frame Flex dimensions

Maximum protrusion for front mounts



No need to readjust lens mounts

Alvium CSI-2 camera mounts are adjusted with high precision during manufacturing. Construction ensures permanent accuracy without need to readjust.

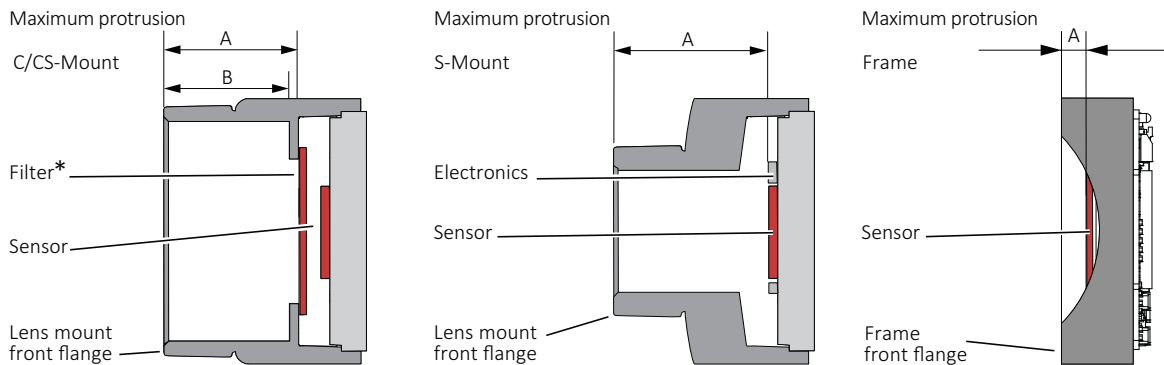

*Only color models are equipped with an IR cut filter

Figure 72: Maximum protrusion CS-Mount and C-Mount, S-Mount, Frame

Figure 72 shows schematics for maximum protrusion of objects (typically lenses), Table 92 shows values for maximum protrusion.



NOTICE

Damage to sensor, optics, or electronics by unsuitable lenses or objects

The sensor, filter, lens, or camera electronics can be damaged if an object (typically a lens) exceeding maximum protrusion is mounted to the camera

- Use lenses with less than the allowed maximum protrusion, see Table 92.
- Mount objects with less than the allowed maximum protrusion, see Table 92.
- See [Mounting the lens](#) on page 242.
- For S-Mount lenses, see [Mounting and focusing S-Mount lenses](#) on page 243.

Mount	Maximum protrusion
C-Mount	13.6 mm
CS-Mount	8.6 mm
S-Mount	11.0 mm
Frame	1.5 mm

Table 92: Alvium CSI-2 cameras maximum protrusion

IR cut filter

Table 93 shows which Alvium models are equipped with an IR cut filter. The filter is permanently installed and cannot be removed.

Color or monochrome model	C-Mount	CS-Mount	S-Mount	Bare Board	Frame
Color	Type Hoya C-5000 IR cut filter			No filter	
Monochrome and VSWIR	No filter				

Table 93: Optical filter availability

Cameras **without** IR cut filter have a higher sensitivity for low-light imaging. Moreover, spectral sensitivity is increased.

Cameras **with** IR cut filter are more accurate in reproduction of color, contrast, and sharpness, as the filter absorbs near-IR wavelengths. See Figure 73 for filter transmission.



Spectral transmission values

The following curve shows typical transmission for type Hoya C-5000 IR cut filter. Values may vary slightly by filter lot.

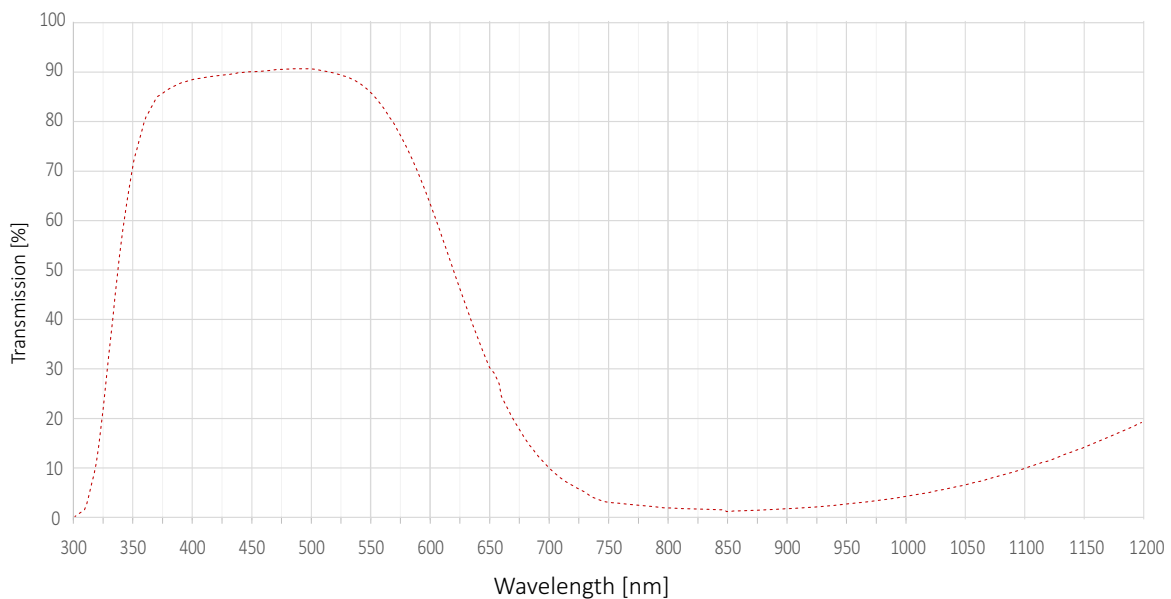

Figure 73: Type Hoya C-5000 IR cut filter spectral transmission (exemplary curve)



S-Mount lenses with IR cut design

For improved image quality, we recommend using S-Mount lenses that are IR-optimized or that have IR cut coating. See the S-Mount Lenses User Guide at www.alliedvision.com/fileadmin/content/documents/products/accessories/lenses/Allied_Vision/User_Guide/S-Mount-Lenses_User-Guide.pdf.

Sensor position accuracy



Alignment for bare board cameras

Alvium bare board cameras are not aligned. You must align these cameras into housings individually, which is extremely difficult and expensive. As a possible solution, Alvium Frame cameras provide alignment areas and holes to fit into individual housings, see [Alvium Frame- use your own optical mount](#) on page 21.

Housed standard and Flex cameras: Sensor shift and rotation

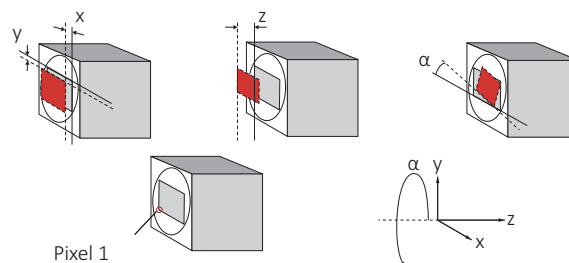

Gray rectangle: Reference sensor position **Red rectangle:** Current position
Straight line: Reference edge **Dotted line:** Current reference edge

The orientation of the z-axis deviates from scientific conventions to define tolerances of the flange focal distance.

Figure 74: Sensor shift and rotation

The following table defines the manufacturing accuracy for sensor positioning with housed standard and Flex cameras.

Criteria	Subject	Properties
Alignment method		Optical alignment of the photosensitive sensor area into the camera front module (lens mount front flange)
Reference Points	Sensor	Center of the pixel area (photo sensitive cells)
	Camera	Center of the lens mount
Accuracy	x/y-axis ¹	±150 µm (sensor shift)
	z	0 to -100 µm (optical back focal length)
	α ¹	±0.5 deg (sensor rotation as the deviation from the parallel to the camera bottom)

¹ We cannot measure or guarantee these values for S-Mount hardware options that are manufactured on customer request for: Alvium 1800 C-052, C-203, C-234, C-235, C-291, C-507, C-508, C-511, C-811, C-812 UV, C-895, C-1236, C-1242, C-1620, C-2040, C-2050, and C-2460.

Table 94: Alvium CSI-2 cameras, criteria of sensor position accuracy

Values for Alviium Frame cameras

For sensor shift and rotation with Alviium Frame cameras, see [Housed Alviium Frame: Sensor shift and rotation](#) on page 205. For sensor tilt, see [All housed Alviium CSI-2 cameras: Sensor tilt](#) on page 205.

Housed Alviium Frame: Sensor shift and rotation

The following table defines the manufacturing accuracy for sensor positioning with housed Alviium Frame cameras. For sensor tilt, see [All housed Alviium CSI-2 cameras: Sensor tilt](#) on page 205.

Criteria	Subject	Properties
Alignment method		Optical alignment of the photosensitive sensor area into the camera front module (lens mount front flange)
Reference Points	Sensor	Center of the pixel area (photo sensitive cells)
	Camera	Center of the Frame lens mount
Accuracy	x/y-axis	$\pm 90 \mu\text{m}$ (sensor shift)
	z	0 to $-50 \mu\text{m}$ (optical back focal length)
	α^1	$\pm 0.5 \text{ deg}$ (sensor rotation as the deviation from the parallel to the camera bottom)

Table 95: Alviium CSI-2 Frame cameras, sensor shift and rotation

All housed Alviium CSI-2 cameras: Sensor tilt

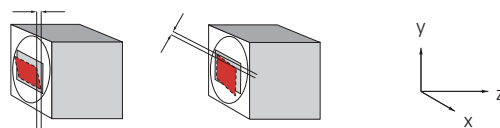

Gray rectangle: Reference sensor position **Red rectangle:** Current position

Figure 75: Sensor tilt

The following table defines sensor tilt as the variance between highest and lowest pixel of a sensor along the z-axis, measured in micrometers.

Alviium model	Pixel size	Maximum tilt
Alviium 1500 C-050m/c	$4.8 \mu\text{m} \times 4.8 \mu\text{m}$	$47 \mu\text{m}$
Alviium 1500 C-120m/c	$3.75 \mu\text{m} \times 3.75 \mu\text{m}$	$29 \mu\text{m}$

Table 96: Sensor tilt (sheet 1 of 2)

Alvium model	Pixel size	Maximum tilt
Alvium 1500 C-210m/c	2.2 μm \times 2.2 μm	15 μm
Alvium 1500 C-500m/c	2.2 μm \times 2.2 μm	15 μm
Alvium 1500 C-501m/c NIR	2.2 μm \times 2.2 μm	15 μm
Alvium 1800 C-Series		
Alvium 1800 C-030 VSWIR	5 μm \times 5 μm	50 μm
Alvium 1800 C-040m/c	6.9 μm \times 6.9 μm	95 μm
Alvium 1800 C-052m/c	9 μm \times 9 μm	36 μm
Alvium 1800 C-130 VSWIR	5 μm \times 5 μm	50 μm
Alvium 1800 C-158m/c	3.45 μm \times 3.45 μm	24 μm
Alvium 1800 C-203m/c	4.5 μm \times 4.5 μm	41 μm
Alvium 1800 C-234m/c	5.86 μm \times 5.86 μm	69 μm
Alvium 1800 C-235m/c	5.86 μm \times 5.86 μm	69 μm
Alvium 1800 C-240m/c	3.45 μm \times 3.45 μm	24 μm
Alvium 1800 C-291m/c	4.5 μm \times 4.5 μm	18 μm
Alvium 1800 C-319m/c	3.45 μm \times 3.45 μm	24 μm
Alvium 1800 C-500m/c	2.2 μm \times 2.2 μm	15 μm
Alvium 1800 C-507m/c	3.45 μm \times 3.45 μm	24 μm
Alvium 1800 C-508m/c	3.45 μm \times 3.45 μm	24 μm
Alvium 1800 C-510m/c	2.74 μm \times 2.74 μm	18 μm
Alvium 1800 C-511m/c	2.74 μm \times 2.74 μm	18 μm
Alvium 1800 C-811m/c	2.74 μm \times 2.74 μm	18 μm
Alvium 1800 C-812 UV	2.74 μm \times 2.74 μm	15 μm
Alvium 1800 C-895m/c	3.45 μm \times 3.45 μm	24 μm
Alvium 1800 C-1236m/c	3.45 μm \times 3.45 μm	24 μm
Alvium 1800 C-1240m/c	2.74 μm \times 2.74 μm	18 μm
Alvium 1800 C-1242m/c	3.45 μm \times 3.45 μm	24 μm
Alvium 1800 C-1640m/c	2.74 μm \times 2.74 μm	18 μm
Alvium 1800 C-2040m/c	2.74 μm \times 2.74 μm	18 μm
Alvium 1800 C-2050m/c	2.4 μm \times 2.4 μm	12 μm
Alvium 1800 C-2460m/c	2.74 μm \times 2.74 μm	18 μm

Table 96: Sensor tilt (sheet 2 of 2)



User sets

Supported features

UserSet features enable to store individual settings on selected Alvium 1800 C cameras. These user sets can be loaded by default, without needing to set values by software after every restart of the camera. Or they can be used to switch between different settings, for example, to adjust from daylight to artificial light.

User sets support all features except for:

- Selectors
- Command features
- Read-only features
- Features that do not apply to the corresponding interface, such as USB related features on a CSI-2 camera
- Features in the LUTControl1 category.

Trigger features and UserSetDefault

Trigger features are reset to default values when the default user set is loaded.

Column `UserSetLoad` displays how user values are affected when the command for `UserSetLoad` is executed.

Feature	Default value	UserSetDefault
<code>TriggerActivation</code>	<i>RisingEdge</i>	Default value
<code>TriggerMode</code>	<i>Off</i>	Default value
<code>TriggerSelector</code>	<i>AcquisitionStart</i>	User value
<code>TriggerSoftware</code>	[Command]	Not applicable
<code>TriggerSource</code>	<i>Software</i>	Default value

Table 97: Trigger features being reset

Camera feature availability

Alvium CSI-2 cameras support a number of standard and extended controls and features. The following tables compare the availability of selected controls and features by model.



Feature descriptions and firmware downloads

GenICam for CSI-2 Access: Alvium Features Reference:

www.alliedvision.com/en/support/technical-documentation/alvium-csi-2-documentation

Other access modes: Alvium CSI-2 Register Controls Reference:

www.alliedvision.com/en/support/technical-documentation/alvium-csi-2-documentation

Firmware downloads: www.alliedvision.com/en/support/firmware-downloads

Image control	Monochrome models	Color models	Supported models
Adaptive noise correction	✓	✓	All 1800 C models
Auto exposure	✓	✓	All
Auto gain	✓	✓	All
Auto white balance	-	✓	All
Color transformation (including hue, saturation)	-	✓	All
Contrast	✓	✓	All 1800 C models
Custom convolution	✓	✓	All 1800 C models
De-Bayering up to 5x5	-	✓	All
Digital binning	✓	✓	All
DPC (defect pixel correction)	✓	✓	All
FPNC (fixed pattern noise correction)	✓	✓	All, except for: 1800 C-030 VSWIR, -052, -130 VSWIR, 203, -234, -235, -291, -895, -2050
Gamma	✓	✓	All
Lens shading correction	✓	✓	All 1800 C models
Look up table (LUT)	✓	✓	All 1800 C models
Reverse X/Y	✓	✓	All

Table 98: Image control features by Alvium CSI-2 camera model (sheet 1 of 2)

Image control	Monochrome models	Color models	Supported models
Sensor binning	✓	-	1800 C-158m, -203m, -240m, -291m, -500, -508m, -510m, -511m, -811m, -812 UV, -1242m, -1620m, -2040m, -2460m
Sharpness/Blur	✓	✓	All
Single ROI (region of interest)	✓	✓	All

Table 98: Image control features by Alvium CSI-2 camera model (sheet 2 of 2)

Camera control	Monochrome models	Color models	Supported models
Acquisition frame rate	✓	✓	All
Counters and timers	✓	✓	All 1800 C models
Firmware update in the field	✓	✓	All
Image chunk data	✓	✓	All 1800 C models
I/O and trigger control	✓	✓	All
Sensor ADC readout modes (SensorBitDepth)	✓	✓	1800 C-030 VSWIR, -040, -052, -130 VSWIR, -158, -203, -234, -235, -240, -291, -508
Serial I/Os	✓	✓	All 1800 C models
Temperature monitoring (mainboard, companion board, interface board)	✓	✓	All
User sets	✓	✓	All 1800 C models

Table 99: Camera control features by Alvium CSI-2 camera model

Lenses: Focal length vs. field of view



This chapter includes:

About this chapter	211
Optical vignetting with certain lenses	211
About S-Mount lenses	212
Focal length vs. field of view	212

About this chapter

This section presents tables that list selected fields of view (FOV) depending on sensor size, distance, and focal length of the lens.

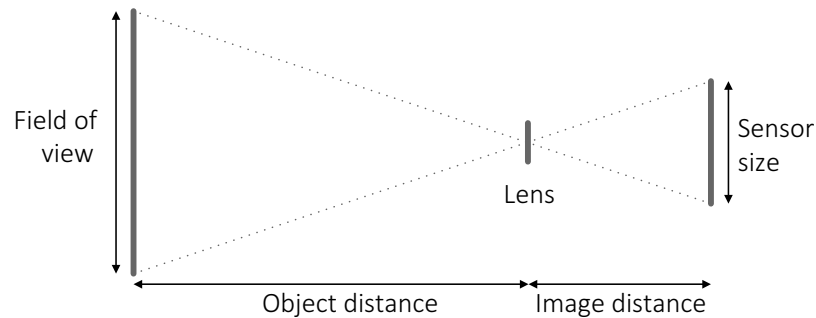

Figure 76: Parameters used in tables for focal length versus FOV



Allied Vision S-Mount lenses

For technical data of Allied Vision S-Mount lenses with dedicated operating instructions, see the S-Mount Lenses User Guide at www.alliedvision.com/fileadmin/content/documents/products/accessories/lenses/Allied_Vision/User_Guide/S-Mount-Lenses_User-Guide.pdf.

Parameters in tables

The distance to the object is measured from the first principal the plane of the lens to the object. For some lenses, manufacturers do not define the principal plane position. Production spread causes tolerances for all values, including actual focal lengths. Calculations apply for image reproduction without distortion. Therefore, values do not apply for fisheye lenses.

Please ask your Allied Vision Sales representative in case you need more information.

Optical vignetting with certain lenses

Lenses with short focal lengths may show optical vignetting at the edges of the image. Microlenses on the sensor pixels can increase the effect.

For demanding applications, we suggest testing camera and lens to find a suitable setup. If you have questions, please contact your Allied Vision Sales representative.

About S-Mount lenses

Alvium CSI-2 models with S-Mount have no filter. For typical applications, we recommend using S-Mount lenses with an integrated IR cut filter for a better image quality.

Read [Mounting and focusing S-Mount lenses](#) on page 243 to avoid damage when using S-Mount lenses.

Focal length vs. field of view

Alvium 1500 C-050m/c

Values for 1500 C-050m/c cameras (aspect ratio 1:1.34) with Type 1/3.6 (4.9 mm diagonal) sensors:

Focal length [mm]	Field of view (H × V [mm])	
	Object distance = 500 mm	Object distance = 1000 mm
2.8	689 × 517	1381 × 1036
3.6	535 × 401	1073 × 805
4.8	400 × 300	804 × 603
6	319 × 239	643 × 482
8	239 × 179	481 × 361
12	158 × 118	319 × 239
16	117 × 88	239 × 179
25	74 × 55	151 × 113

Table 100: Focal length versus field of view for Alvium 1500 C-050m/c

Alvium 1500 C-120m/c

Values for 1500 C-120m/c cameras with Type 1/3 (6.0 mm diagonal) sensors:

Focal length [mm]	Field of view (H × V [mm])	
	Object distance = 500 mm	Object distance = 1000 mm
2.8	852 × 639	1709 × 1282
3.6	662 × 496	1329 × 996
4.8	495 × 371	995 × 746
6	395 × 296	795 × 596
8	295 × 221	595 × 446
12	195 × 146	395 × 296
16	145 × 109	295 × 221
25	91 × 68	187 × 140

Table 101: Focal length versus field of view for Alvium 1500 C-120m/c

Alvium 1500 C-210m/c

Values for 1500 C-210m/c cameras (aspect ratio 1:1.75) with Type 1/3.6 (4.9 mm diagonal) sensors:

Focal length [mm]	Field of view (H × V in [mm])	
	Object distance = 500 mm	Object distance = 1000 mm
2.8	746 × 426	1496 × 855
3.6	579 × 331	1162 × 664
4.8	433 × 248	871 × 498
6	346 × 198	696 × 398
8	258 × 148	521 × 298
12	171 × 98	346 × 198
16	127 × 73	258 × 148
25	80 × 46	164 × 94

Table 102: Focal length versus field of view for Alvium 1500 C-210m/c

Alvium 1500 C-500m/c, 1500 C-501m/c NIR

Values for 1500 C-500m/c and 1500 C-501m/c NIR cameras with Type 1/2.5 (7.1 mm diagonal) sensors:

Focal length [mm]	Field of view (H × V in [mm])	
	Object distance = 500 mm	Object distance = 1000 mm
2.8	1013 × 759	2031 × 1523
3.6	786 × 590	1578 × 1184
4.8	588 × 441	1182 × 887
6	469 × 352	945 × 709
8	351 × 263	707 × 530
12	232 × 174	469 × 352
16	172 × 129	351 × 263
25	108 × 81	222 × 167

Table 103: Focal length versus field of view for Alvium 1500 C-500m/c and 1500 C-501m/c NIR

Alvium 1800 C-030 VSWIR

Values for 1800 C-030 VSWIR cameras with Type 1/4 (4.1 mm diagonal) sensors:

Focal length [mm]	Field of view (H × V [mm])	
	Object distance = 500 mm	Object distance = 1000 mm
4	407 × 322	817 × 647
5	775 × 773	1557 × 1553
6	644 × 642	1296 × 1293
8	481 × 480	970 × 968
12	318 × 317	644 × 642
16	237 × 236	481 × 480
25	149 × 148	305 × 304
35	104 × 104	216 × 215
50	70 × 70	149 × 148

Table 104: Focal length versus field of view for Alvium 1800 C-030 VSWIR

Alvium 1800 C-040m/c

Values for 1800 C-040m/c cameras with Type 1/2.9 (6.3 mm diagonal) sensors:

Focal length [mm]	Field of view (H × V [mm])	
	Object distance = 500 mm	Object distance = 1000 mm
2.8	892 × 667	1789 × 1337
3.6	693 × 518	1390 × 1039
4.8	518 × 387	1041 × 778
6	414 × 309	832 × 622
8	309 × 231	623 × 465
12	204 × 153	414 × 309
16	152 × 114	309 × 231
25	95 × 71	196 × 146

Table 105: Focal length versus field of view for Alvium 1800 C-040m/c

Alvium 1800 C-052m/c

Values for 1800 C-052m/c cameras with Type 1/1.7 (9.2 mm diagonal) sensors:

Focal length [mm]	Field of view (H × V [mm])	
	Object distance = 500 mm	Object distance = 1000 mm
5	671 × 560	1348 × 1125
6	558 × 466	1122 × 937
8	417 × 348	840 × 701
12	275 × 230	558 × 466
16	205 × 171	417 × 348
25	129 × 107	264 × 221
35	90 × 75	187 × 156
50	61 × 51	129 × 107

Table 106: Focal length versus field of view for Alvium 1800 C-052m/c

Alvium 1800 C-130 VSWIR

Values for 1800 C-130 VSWIR cameras with Type 1/2 (8.2 mm diagonal) sensors:

Focal length [mm]	Field of view (H × V [mm])	
	Object distance = 500 mm	Object distance = 1000 mm
5	671 × 560	1348 × 1125
6	558 × 466	1122 × 937
8	417 × 348	840 × 701
12	275 × 230	558 × 466
16	205 × 171	417 × 348
25	129 × 107	264 × 221
35	90 × 75	187 × 156
50	61 × 51	129 × 107

Table 107: Focal length versus field of view for Alvium 1800 C-130 VSWIR

Alvium 1800 C-158m/c

Values for 1800 C-158m/c cameras with Type 1/2.9 (6.3 mm diagonal) sensors:

Focal length [mm]	Field of view (H × V [mm])	
	Object distance = 500 mm	Object distance = 1000 mm
2.8	892 × 667	1789 × 1337
3.6	693 × 518	1390 × 1039
4.8	518 × 387	1041 × 778
6	414 × 309	832 × 622
8	309 × 231	623 × 465
12	204 × 153	414 × 309
16	152 × 114	309 × 231
25	95 × 71	196 × 146

Table 108: Focal length versus field of view for Alvium 1800 C-158m/c

Alvium 1800 C-203m/c

Values for 1800 C-203m/c cameras with Type 1/1.7 (9.2 mm diagonal) sensors:

Focal length [mm]	Field of view (H × V [mm])	
	Object distance = 500 mm	Object distance = 1000 mm
5	727 × 556	1461 × 1118
6	605 × 462	1217 × 930
8	452 × 345	911 × 696
12	299 × 228	605 × 462
16	222 × 170	452 × 345
25	140 × 107	286 × 219
35	98 × 75	202 × 155
50	66 × 51	140 × 107

Table 109: Focal length versus field of view for Alvium 1800 C-203m/c

Alvium 1800 C-234m/c, 1800 C-235m/c

Values for 1800 C-234m/c and 1800 C-235m/c cameras with Type 1/1.2 (13.4 mm diagonal) sensors:

Focal length [mm]	Field of view (H × V in [mm])	
	Object distance = 500 mm	Object distance = 1000 mm
8	698 × 438 mm	1407 × 884 mm
12	461 × 290 mm	933 × 586 mm
16	343 × 215 mm	697 × 438 mm
25	215 × 135 mm	442 × 278 mm
35	150 × 94 mm	312 × 196 mm
50	102 × 64 mm	215 × 135 mm

Table 110: Focal length versus field of view for Alvium 1800 C-234m/c and 1800 C-235m/c

Alvium 1800 C-240m/c

Values for 1800 C-240m/c cameras with Type 1/2.3 (7.9 mm diagonal) sensors:

Focal length [mm]	Field of view (H × V in [mm])	
	Object distance = 500 mm	Object distance = 1000 mm
4.8	691 × 433	1389 × 871
6	552 × 346	1110 × 696
8	412 × 258	831 × 521
12	272 × 171	552 × 346
16	203 × 127	412 × 258
25	127 × 80	261 × 164
35	89 × 56	185 × 116
50	60 × 38	127 × 80

Table 111: Focal length versus field of view for Alvium 1800 C-240m/c

Alvium 1800 C-291m/c

Values for 1800 C-291m/c cameras with Type 2/3 (10.8 mm diagonal) sensors:

Focal length [mm]	Field of view (H × V in [mm])	
	Object distance = 500 mm	Object distance = 1000 mm
6	644 × 642	1296 × 1293
8	481 × 480	970 × 968
12	318 × 317	644 × 642
16	237 × 236	481 × 480
25	149 × 148	305 × 304
35	104 × 104	216 × 215
50	70 × 70	149 × 148

Table 112: Focal length versus field of view for Alvium 1800 C-291m/c

Alvium 1800 C-319m/c

Values for 1800 C-319m/c cameras with Type 1/1.8 (8.9 mm diagonal) sensors:

Focal length [mm]	Field of view (H × V in [mm])	
	Object distance = 500 mm	Object distance = 1000 mm
4.8	735 × 550	1476 × 1104
6	586 × 439	1180 × 882
8	438 × 328	883 × 661
12	290 × 217	586 × 439
16	215 × 161	438 × 328
25	135 × 101	278 × 208
35	95 × 71	196 × 147
50	64 × 48	135 × 101

Table 113: Focal length versus field of view for Alvium 1800 C-319m/c

Alvium 1800 C-500m/c

Values for 1800 C-500m/c cameras with Type 1/2.5 (7.1 mm diagonal) sensors:

Focal length [mm]	Field of view (H × V in [mm])	
	Object distance = 500 mm	Object distance = 1000 mm
2.8	1013 × 759	2031 × 1523
3.6	786 × 590	1578 × 1184
4.8	588 × 441	1182 × 887
6	469 × 352	945 × 709
8	351 × 263	707 × 530
12	232 × 174	469 × 352
16	172 × 129	351 × 263
25	108 × 81	222 × 167

Table 114: Focal length versus field of view for Alvium 1800 C-500m/c

Alvium 1800 C-507m/c, 1800 C-508m/c

Values for 1800 C-507m/c and 1800 C-508 cameras with Type 2/3 (11.1 mm diagonal) sensors:

Focal length [mm]	Field of view (H × V in [mm])	
	Object distance = 500 mm	Object distance = 1000 mm
6	700 × 584	1408 × 1175
8	523 × 436	1054 × 880
12	346 × 288	700 × 584
16	257 × 215	523 × 436
25	162 × 135	332 × 277
35	113 × 94	234 × 196
50	77 × 64	162 × 135

Table 115: Focal length versus field of view for Alvium 1800 C-507m/c and 1800 C-508m/c

Alvium 1800 C-510m/c, 1800 C-511m/c

Values for 1800 C-510m/c and 1800 C-511m/c cameras with Type 1/1.8 (8.8 mm diagonal) sensors:

Focal length [mm]	Field of view (H × V in [mm])	
	Object distance = 500 mm	Object distance = 1000 mm
5	671 × 560	1348 × 1125
6	558 × 466	1122 × 937
8	417 × 348	840 × 701
12	275 × 230	558 × 466
16	205 × 171	417 × 348
25	129 × 107	264 × 221
35	90 × 75	187 × 156
50	61 × 51	129 × 107

Table 116: Focal length versus field of view for Alvium 1800 C-510m/c and 1800 C-511m/c

Alvium 1800 C-811m/c, 1800 C-812 UV

Values for 1800 C-811m/c and 1800 C-812 UV cameras Type 2/3 (11 mm diagonal) sensors:

Focal length [mm]	Field of view (H × V in [mm])	
	Object distance = 500 mm	Object distance = 1000 mm
5	773 × 773	1553 × 1553
6	642 × 642	1293 × 1293
8	480 × 480	968 × 968
12	317 × 317	642 × 642
16	236 × 236	480 × 480
25	148 × 148	304 × 304
35	104 × 104	215 × 215
50	70 × 70	148 × 148

Table 117: Focal length versus field of view for Alvium 1800 C-811m/c and 1800 C-812 UV

Alvium 1800 C-895m/c

Values for 1800 C-895m/c cameras with Type 1 (16 mm diagonal) sensors:

Focal length [mm]	Field of view (H × V in [mm])	
	Object distance = 500 mm	Object distance = 1000 mm
12	577 × 305	1168 × 618
16	429 × 227	873 × 462
25	270 × 143	553 × 293
35	189 × 100	391 × 286
50	128 × 68	270 × 143
100	57 × 30	128 × 68
135	38 × 20	91 × 48

Table 118: Focal length versus field of view for Alvium 1800 C-895m/c

Alvium 1800 C-1236m/c

Values for 1800 C-1236m/c cameras with Type 1.1 (17.6 mm diagonal) sensors:

Focal length [mm]	Field of view (H × V in [mm])	
	Object distance = 500 mm	Object distance = 1000 mm
8	872 × 638	1759 × 1287
12	577 × 422	1168 × 854
16	429 × 314	872 × 638
25	270 × 197	553 × 405
35	188 × 138	391 × 286
50	128 × 93	270 × 197
75	80 × 59	175 × 128

Table 119: Focal length versus field of view for Alvium 1800 C-1236m/c

Alvium 1800 C-1240m/c

Values for 1800 C-1240m/c cameras with Type 1/1.7 (9.33 mm diagonal) sensors:

Focal length [mm]	Field of view (H × V in [mm])	
	Object distance = 500 mm	Object distance = 1000 mm
4.8	763 × 578	1534 × 1161
6	609 × 461	1226 × 928
8	455 × 344	918 × 694
12	301 × 228	609 × 461
16	224 × 169	455 × 344
25	141 × 106	289 × 218
35	98 × 74	204 × 154
50	67 × 50	141 × 106

Table 120: Focal length versus field of view for Alvium 1800 C-1240m/c

Alvium 1800 C-1242m/c

Values for 1800 C-1242m/c cameras with Type 1/1.1 (14 mm diagonal) sensors:

Focal length [mm]	Field of view (H × V in [mm])	
	Object distance = 500 mm	Object distance = 1000 mm
6	931 × 679	1874 × 1365
8	696 × 507	1403 × 1022
12	460 × 335	931 × 679
16	342 × 249	696 × 507
25	215 × 157	441 × 321
35	150 × 109	312 × 227
50	102 × 74	215 × 157
75	64 × 47	139 × 102

Table 121: Focal length versus field of view for Alvium 1800 C-1242m/c

Alvium 1800 C-1620m/c

Values for 1800 C-1620m/c cameras with Type 1.1 (16.8mm diagonal) sensors:

Focal length [mm]	Field of view (H × V in [mm])	
	Object distance = 500 mm	Object distance = 1000 mm
5	1445 × 825	2905 × 1658
6	1202 × 686	2419 × 1380
8	898 × 512	1810 × 1033
12	594 × 339	1202 × 686
16	442 × 252	898 × 512
25	277 × 158	569 × 325
35	194 × 111	403 × 230
50	131 × 75	277 × 158
75	83 × 47	180 × 103

Table 122: Focal length versus field of view for Alvium 1800 C-1620m/c

Alvium 1800 C-2040m/c

Values for 1800 C-2040m/c cameras with Type 1.1 (17.5 mm diagonal) sensors:

Focal length [mm]	Field of view (H × V in [mm])	
	Object distance = 500 mm	Object distance = 1000 mm
6	1018 × 1018	2048 × 2048
8	760 × 760	1533 × 1533
12	503 × 503	1018 × 1018
16	374 × 374	760 × 760
25	235 × 235	482 × 482
35	164 × 164	341 × 341
50	111 × 111	235 × 235
75	70 × 70	152 × 152
85	60 × 60	133 × 133

Table 123: Focal length versus field of view for Alvium 1800 C-2040m/c

Alvium 1800 C-2050m/c

Values for 1800 C-2050m/c cameras with Type 1 (15.8 mm diagonal) sensors:

Focal length [mm]	Field of view (H × V in [mm])	
	Object distance = 500 mm	Object distance = 1000 mm
8	811 × 542	1636 × 1093
12	536 × 358	1086 × 726
16	399 × 267	811 × 542
25	251 × 167	514 × 344
35	175 × 117	364 × 243
50	119 × 79	251 × 167
75	75 × 50	163 × 109
85	64 × 43	142 × 95
100	53 × 35	119 × 79

Table 124: Focal length versus field of view for Alvium 1800 C-2050m/c

Alvium 1800 C-2460m/c

Values for 1800 C-2460m/c cameras with Type 1.2 (19.3 mm diagonal) sensors:

Focal length [mm]	Field of view (H × V in [mm])	
	Object distance = 500 mm	Object distance = 1000 mm
8	898 × 776	1810 × 1566
12	594 × 513	1202 × 1040
16	442 × 382	898 × 776
25	277 × 240	569 × 492
35	194 × 168	403 × 348
50	131 × 114	277 × 240
75	83 × 72	180 × 156

Table 125: Focal length versus field of view for Alvium 1800 C-2460m/c

Access modes





This chapter includes:

Overview	227
Notes on GenICam for CSI-2 Access	227
V4L2 controls and register controls	229
GenICam features	229

Overview

The driver for Alvium CSI-2 cameras supports different access modes to suit the various requirements of individual applications:

CSI-2 access mode	Supported models	Description
Direct Register Access 	All	Controls the camera by reading from and writing to registers, using an embedded board or an FPGA. See the Alvium CSI-2 Register Controls Reference document at www.alliedvision.com/en/support/technical-documentation/alvium-csi-2-documentation .
Video4Linux Access 	All	Controls the camera by V4L2 controls, using the Allied Vision driver for CSI-2 cameras directly. Existing PC-based machine vision applications can be scaled down to V4L2 on lean embedded systems, reducing power consumption and costs.
GenICam for CSI-2 Access 	All 1800 C models ¹	Controls the camera by GenICam features, using the Allied Vision driver for CSI-2 cameras directly. Alvium CSI-2 cameras can be used to replace other cameras on existing PC-based machine vision applications, reducing power consumption and costs. See the Alvium Features Reference document at www.alliedvision.com/en/support/technical-documentation/alvium-csi-2-documentation .

¹ Alvium 1500 C models are excluded from **GenICam for CSI-2 Access**.

Table 126: Access modes overview

Figure 77 on page 228 shows how cameras are controlled using the different access modes.

Notes on GenICam for CSI-2 Access

Before using **GenICam for CSI-2 Access**, see [GenICam for CSI-2 Access- Camera operation](#) on page 230 for smooth operation.

Data flow

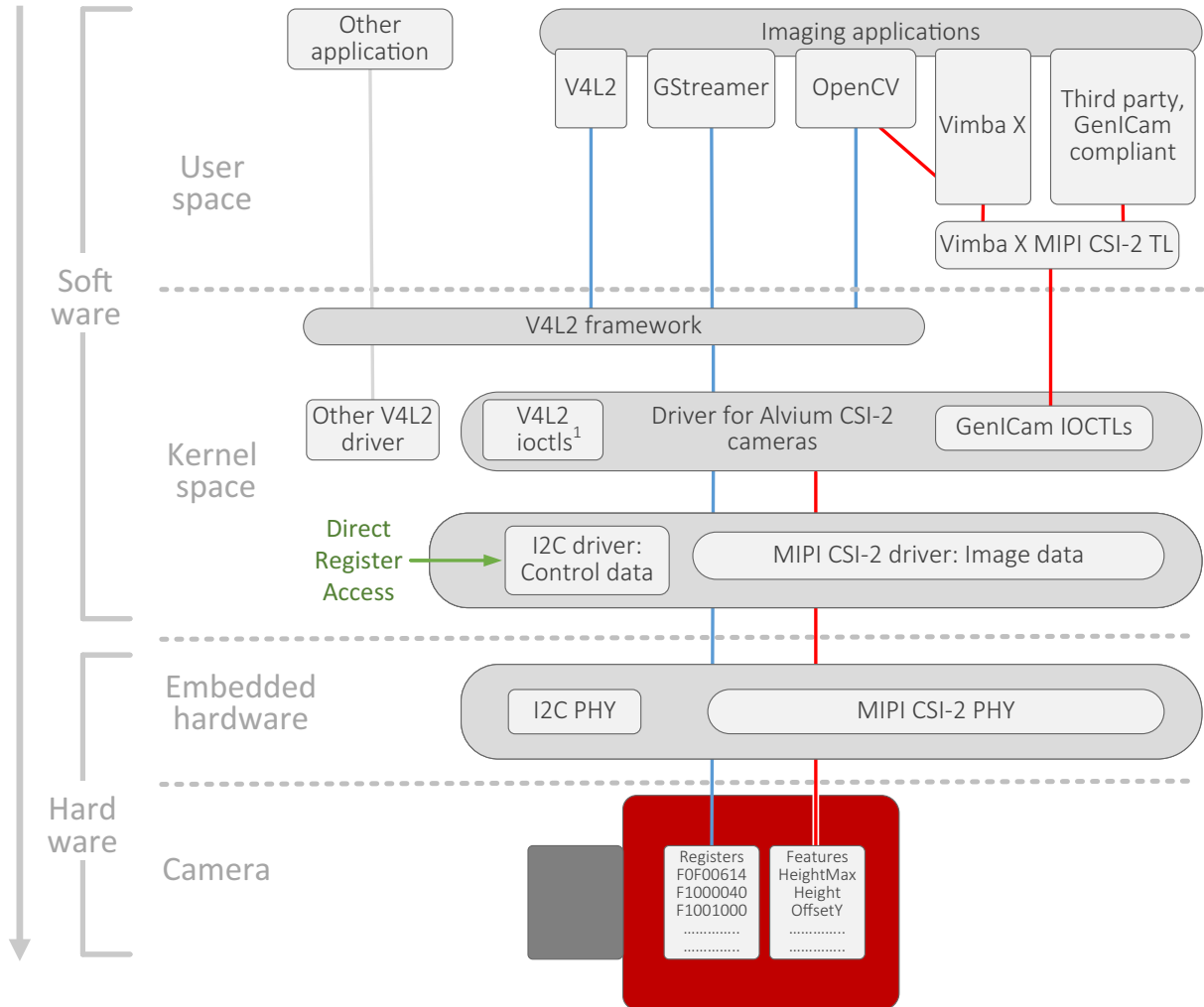

Legend

- Video4Linux Access
- GenICam for CSI-2 Access

¹ ioctls = ioctl() function

Figure 77: Camera control using the different access modes

Direct Register Access: Data is read from and written to registers directly.

Video4Linux Access: V4L2 controls registers are used.

GenICam for CSI-2 Access: GenICam features are used.

V4L2 controls and register controls

Embedded applications often use V4L2 controls provided with the Linux kernel to operate and configure the camera.



V4L2 controls - general information

Consider that V4L2 controls change through the Linux kernel development.

For information on such as supported Linux kernels, see <https://github.com/alliedvision>.

For a description of V4L2 controls related to the **current kernel version**, see <https://linuxtv.org>.

For embedded board adapters, see CSI-2 accessories at www.alliedvision.com/en/support/technical-documentation/alvium-csi-2-documentation.



V4L2 controls - reference for camera specific information

Almost every register control has an equivalent V4L2 control. For applications based on V4L2 Access, we recommend using the Direct Register Access Reference for camera specific information.

www.alliedvision.com/en/support/technical-documentation/alvium-csi-2-documentation.

GenICam features

Machine vision applications typically use GenICam SFNC features enabled by a transport layer communicating between a software development kit (SDK) and the interface driver. Selected Alvium 1800 C models support GenICam.



GenICam features - descriptions

For GenICam feature descriptions, see the Alvium Features Reference at www.alliedvision.com/en/support/technical-documentation/alvium-csi-2-documentation.

GenICam for CSI-2 Access - Camera operation

Need to restart the embedded board

Whenever you change between different access modes:

- You must restart the embedded board.
- Closing the application while the camera is streaming is not sufficient.

Debouncer

If `LineDebounceMode` is enabled, an error is shown when changing the `LineDebounceDuration`. You must power cycle the camera to enable operation again.

Device reset

The `DeviceReset` command does not work.

User sets

Settings, including user sets are not transferred between the access modes.

Before you switch from **GenICam for CSI-2 Access** to another access mode, disable individual user sets. Set `UserSetDefault` and `UserSetSelector` to *Default* to enable factory settings.

Installing the hardware



This chapter includes:

Touching hot cameras	232
Sensor damage by ESD.....	232
Scope of instructions	232
Bare board cameras	232
Connecting FPC cable and FPC connectors	234
Mounting the heat sink.....	236
Mounting the camera	237
Mounting the lens.....	242

Touching hot cameras



CAUTION

Risk of burns

A camera in operation can reach temperature levels which could cause burns.

- Wear protective gloves when you touch a camera that is heated up.
- Ensure proper cooling of the camera.

Sensor damage by ESD



NOTICE

Possible damage to the sensor

In Alvium CSI-2 cameras, sensors can be damaged by ESD. In the output image, this may become visible as bubbles or blobs, for example. For details, see [Possible damage to image sensors due to electrostatic charge](#) on page 57.

- Provide ESD protection measures in accordance with technical standards.
- Follow the instructions in [ESD](#) on page 54.

Scope of instructions



Software installation

Software downloads and documentation

This chapter describes hardware installation only. For information on supported Linux distributions and embedded boards, drivers, libraries, and programming examples, see www.alliedvision.com/en/products/software/embedded-software-and-drivers.

Hardware installation

This chapter instructs on using Alvium CSI-2 cameras safely and effectively. However, we cannot provide complete information. The MIPI CSI-2 standard does not specify electrical connections as extensively as USB or GigE standard. Therefore, instructions on camera connections can be general only.

Bare board cameras

If you intend to design an application using bare board cameras, please consider:

- Alvium bare board cameras are not aligned. You must align these cameras into housings individually, which is extremely difficult and expensive. As a possible solution, Alvium Frame cameras provide alignment areas and holes to fit into individual housings, see [Alvium Frame- use your own optical mount](#) on page 21.

- Aligning the sensor to the lens is extremely difficult and expensive. Therefore, we recommend you to do evaluation with housed cameras first.
- Bare board cameras are specialized components. We cannot give all data needed for any application in advance.
- Please let us partner with you for bare board camera applications to ensure a successful design.

Serial numbers of Alvium® chips and bare board cameras

Bare board cameras do not have enough space for a label with all the required information. Therefore, they are shipped with a 25 mm × 25 mm sandwich label on the blister pack. In [Figure 78](#), this label shows, for example:

- Product code: 11500 for a 1500 C-210c Bare Board camera
- Alvium® chip SN (serial number): 183603543
- Camera SN (serial number): R7QW5 as digits and 2D code.

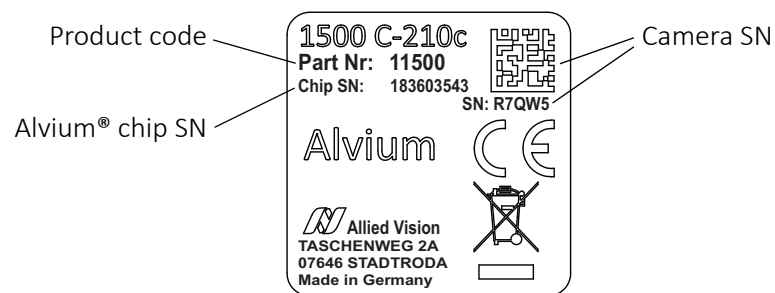

Figure 78: Sandwich label on blister packs shipped for bare board cameras

Before operating the camera, we recommend you to pull the sandwich label off the blister pack and stick it close to the camera.

If the label is lost, please read out with your smart phone the serial number of the Alvium® chip from the 2D code (a) shown in [Figure 79](#). With this number, we can look up the serial number of the camera in our database.

If your smart phone cannot read the 2D code: In [Figure 79](#), for example, the serial number (b) is 221406281.

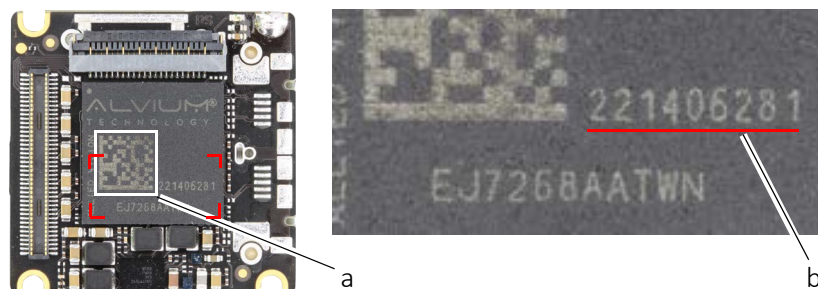

Figure 79: Alvium® chip imprint with detail view (right)

Connecting FPC cable and FPC connectors



Connecting Alvium CSI-2 cameras to embedded boards

- For evaluation, Allied Vision offers components to connect Alvium CSI-2 cameras to embedded boards. **Adapter boards** provide common pinning and voltage for connections to the camera using **FPC cables**. See www.alliedvision.com/en/products/accessories.
- If you want to design your own components to connect Alvium CSI-2 cameras to embedded boards, contact your Allied Vision Sales representative or visit www.alliedvision.com/en/support.

Figure 80 shows how the FPC cable connects to the FPC connector.

Follow the instructions to connect the FPC cable to the camera and to the embedded board.

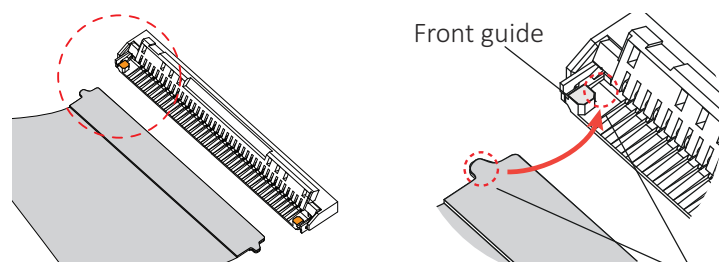

Figure 80: FPC cable and FPC connector (open position)

1. Opening the FPC connector:
With your fingernail*, flip the actuator to open position at 105 degrees to the PCB surface, see Figure 81.

*Or a plastic tool, because metal tools can damage the actuator.

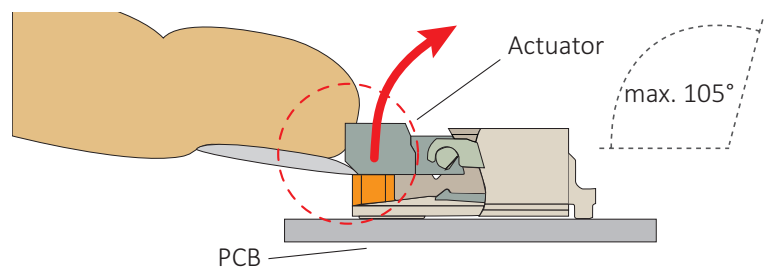

Figure 81: Opening the FPC connector

NOTICE
Damage to the camera by reverse polarity

If Alvium CSI-2 cameras are powered with reverse polarity, camera electronics is damaged.

- Before connecting camera power and I/O power, carefully read [Hirose FH55 connector pin assignment](#) on page 248.
- Connect the cable as shown in this section.

Embedded
board or
adapter board



Figure 82: FPC cable and image data direction

2. **Ensuring proper cable direction between host and camera**, take the FPC cable with conductors facing the FPC connector conductors (see [Figure 83](#)).

3. Inserting the FPC cable:
At a horizontal angle of 90 degrees to the connector's rear (see [Figure 83](#)) and at a vertical angle of 12 degrees to the PCB (see [Figure 84](#)), slowly insert the FPC cable into the actuator...

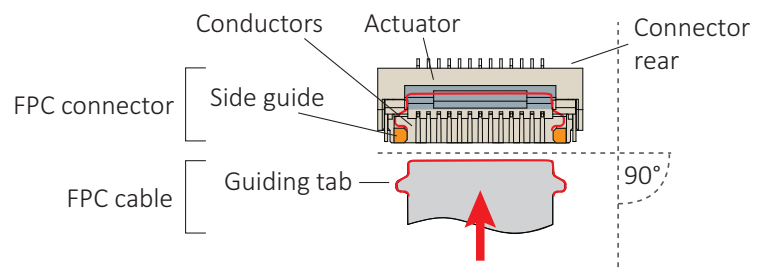

Figure 83: FPC cable and FPC connector

4. ...until cable guiding tabs are caught between connector rear and side guides (see [Figure 83](#)). Pull the cable slightly to ensure guiding tabs are properly engaged.
5. Holding the FPC cable in position, flap down the actuator to closed position (see [Figure 84](#)).

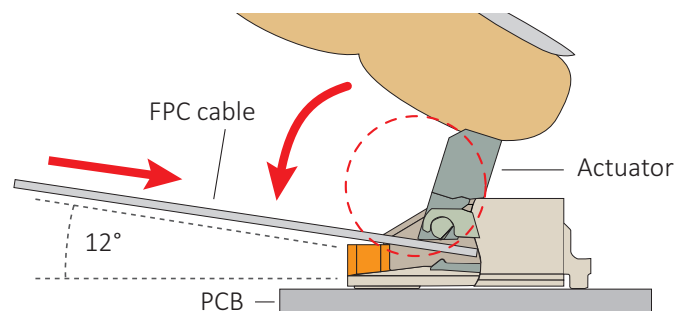

Figure 84: Engaging the FPC cable in the FPC connector

NOTICE
Damage to FPC connectors

A bended FPC cable can break the FPC connector's actuator.
Provide sufficient strain relief at both ends of the cable.

Mounting the heat sink

Keep the operating temperature in the specified range to enable best image quality and to protect the camera from damage. We recommend you to equip Alvium bare board and open housing cameras with heat sinks.



Optimizing heat dissipation

For details, see the Optimum Heat Dissipation for Alvium Cameras application note at www.alliedvision.com/en/support/technical-documentation/alvium-csi-2-documentation.



NOTICE

Damage to the camera by heat sinks mounted improperly

- Allow mechanical contact only at the cooling area.
- Avoid any mechanical stress to the sensor and electronics area.
- Avoid short circuits of the electronics components.



NOTICE

Damage to the sensor, filter, and lens by corrosive substances

Some conductive media for heat sinks contain corrosive substances that can damage optical surfaces of the sensor, filter, and lens.

- Cover the optical path of the camera when you apply heat sink compound or adhesive to prevent substances and fumes from damaging optical surfaces.
- Adhere to the instructions and safety notes provided by the manufacturer of the conductive media.



NOTICE

Damage to camera electronics

Heat sinks can cause short circuits if they are not electrically isolated.

Avoid electrical contact between electronic components by unsuitable heat sinks and thermal conductive media.

Connect components in the **cooling area** (blue area in [Figure 85](#)) to a heat sink, following the instructions of the manufacturer of the heat sink and the thermal conductive media.

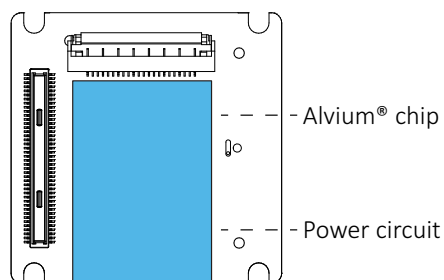

Figure 85: Cooling area for Alvium CSI-2 bare board cameras



Heat sink compound

Because electronic parts vary in height, we have updated our recommendation:

- Use flexible heat sink compound to compensate for potential gaps between the electronic parts to be cooled and heat sinks.
- Consider 1 mm to cover for worst case scenarios.
- For details, see the Alvium STEP files at www.alliedvision.com/en/support/alvium-step-file-downloads.

Mounting the camera



CAUTION

Injury by falling cameras or lenses

A falling camera or lens can cause injury.

- Ensure proper mounting of cameras and lenses, especially for dynamic applications.
- Mount cameras as described in the instructions.
- Always make sure the mounting threads are intact.
- Fasten screws with maximum torque, using the entire thread engagement. For less thread engagement, see [Adapting maximum torque values](#) on page 242.
- We recommend you to apply thread locking.
- Use a lens support for heavy lenses.

Mounting bare board cameras



Heat dissipation and electromagnetic compatibility for bare board cameras

For heat dissipation, see the Optimum Heat Dissipation for Alvium Cameras application note.

For initial guidance on electromagnetic compatibility, see the Electromagnetic Compatibility for Open Housing Alvium Cameras application note.

See www.alliedvision.com/en/support/technical-documentation/alvium-csi-2-documentation.



NOTICE

Damage to the camera by improper mounting

- Allow mechanical contact only at the mounting area.
- Avoid any mechanical stress to the sensor and the electronics area.
- Avoid short circuits of the electronics components.
- Give 2 mm minimum clearance above board components.
- Tighten screws at 0.1 Nm maximum torque.



Alignment for bare board cameras

Alvium bare board cameras are not aligned. You must align these cameras into housings individually, which is extremely difficult and expensive. As a possible solution, Alvium Frame cameras provide alignment areas and holes to fit into individual housings, see [Alvium Frame- use your own optical mount](#) on page 21.

Schematic drawings in [Figure 86](#) show the Alvium CSI-2 bare board camera. Only the mounting area (gray) can be used for mounting. The sensor and electronics area (red) must not be touched nor put at mechanical stress.

a = Mounting hole | b = Mounting hole and chassis ground

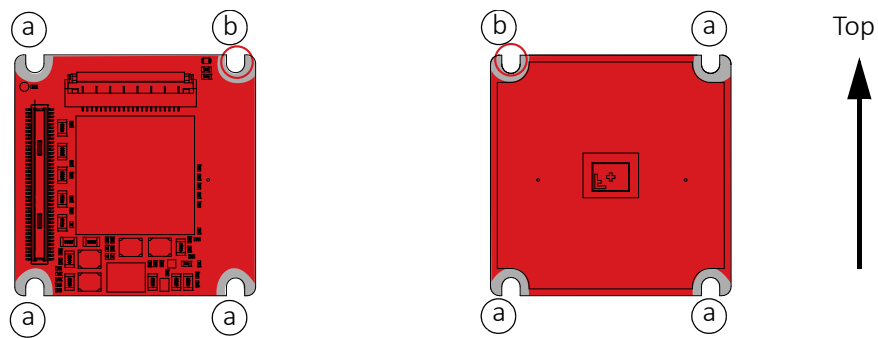

Figure 86: Mounting area of Alvium CSI-2 bare board cameras connector side (left); sensor side (right)

Mount the bare board with four M1.6 screws at 0.1 Nm maximum torque.

Mounting open housing cameras

Bottom or top mounting

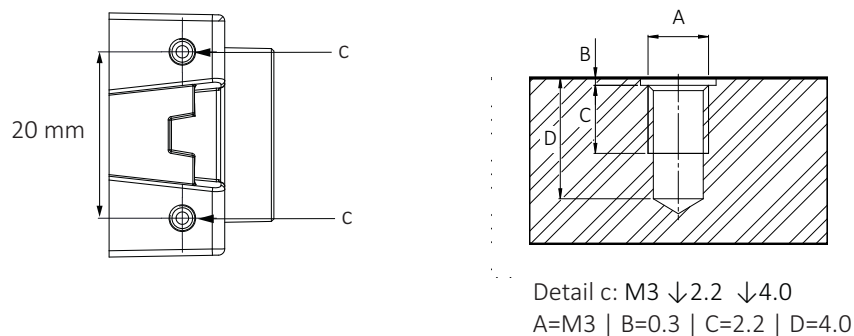

Figure 87: Top and bottom and mounting threads (c)

The maximum torque value applies only if the entire thread engagement is used. For other values, see [Adapting maximum torque values](#) on page 242.

1. Mount the camera to the base using suitable M3 screws at 0.51 Nm maximum torque for a thread engagement (C) of 2.2 mm between screws and mounting threads, see [Figure 87](#). For technical drawings, see [Standard Alvium: Dimensions and mass](#) on page 189.
2. Continue with [Mounting the lens](#) on page 242.

Front mounting

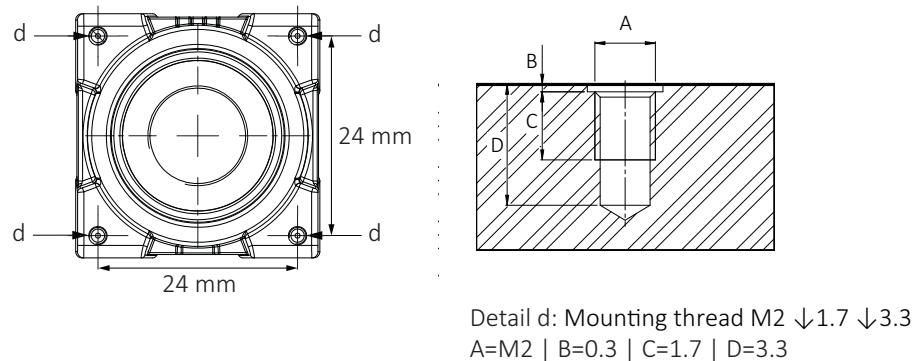

Figure 88: Camera front with mounting threads (d)

The maximum torque value applies only if the entire thread engagement is used. For other values, see [Adapting maximum torque values](#) on page 242.

1. Mount the camera to the base using suitable M2 screws at 0.17 Nm maximum torque for a thread engagement (C) of 1.7 mm between screws and mounting threads, see [Figure 88](#). For technical drawings, see [Standard Alvium: Dimensions and mass](#) on page 189.
We recommend you to additionally use bottom and top mounting threads for a more solid connection.
2. Continue with [Mounting the lens](#) on page 242.

Installing Alvium Frame



CAUTION

Risk of cuts by sharp edges of the circular front opening

- Avoid touching these edges with your fingers.
- Wear protective gloves for handling Alvium Frame cameras with an open circular front opening.

NOTICE
Damage to the sensor

The sensor can be damaged if its surface is exposed to dirt or mechanical stress.

- Ensure that lenses or objects, such as optical elements do not exceed the specified maximum protrusion.
- Keep your fingers and tools outside the area inside the frame flange.
- Provide the following conditions to keep dirt and droplets out of the optical system of camera:
 - Dust-free environment
 - Low relative humidity
 - No condensation.

Aligning the sensor with your optical system

Alvium Frame cameras are manufactured so that the sensor is aligned with your optical system with optimal precision. You can select between alignment methods:

A: Using the lateral alignment areas (1) and the front alignment area (2).

B: Using the front area (2) and the two alignment holes (3).

A Alignment by using the lateral alignment areas (1) and the front area (2)

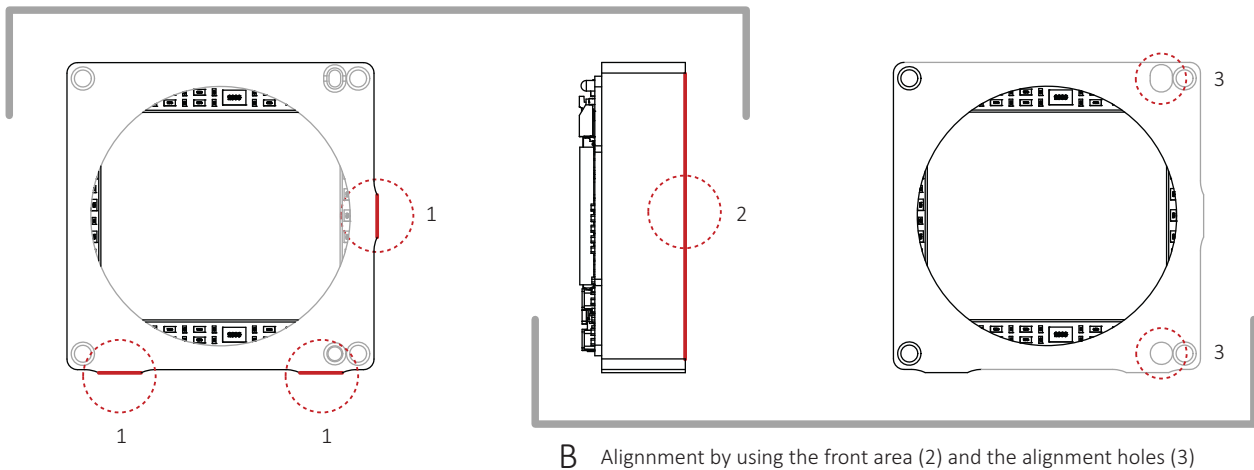

Figure 89: Alignment methods



Dimensions and accuracy

For the dimensions and accuracy of the alignment areas and the alignment holes, see [Alvium Frame: Technical drawings](#) on page 200.

For the accuracy of the sensor position, see [Housed Alvium Frame: Sensor shift and rotation](#) on page 205 and [All housed Alvium CSI-2 cameras: Sensor tilt](#) on page 205.

When you design Alvium Frame cameras into your system, observe values for:

- Flange focal distance, optical: 3.576 mm
- Maximum protrusion of 1.5 mm into the frame measured from the front area (2).

Mounting Alvium Frame

Especially for dynamic applications with high acceleration, mount the camera using all 4 mounting threads.

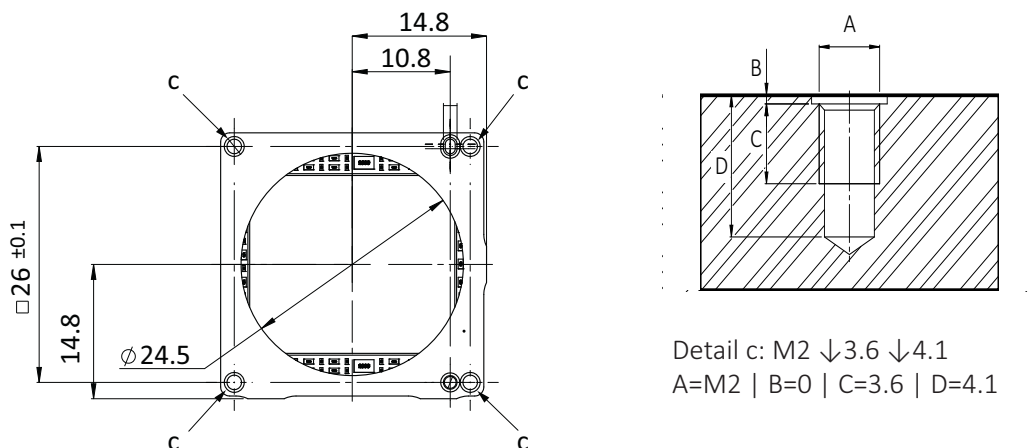

Figure 90: Mounting threads Alvium Frame

The maximum torque value applies only if the entire thread engagement is used. For other values, see [Adapting maximum torque values](#) on page 242. For technical drawings, with further values and tolerances, and references for alignment, see [Alvium Frame: Technical drawings](#) on page 200.

As shown in [Figure 90](#), mount the camera to the base using suitable M2 screws for the 4 mounting threads: At 0.4 Nm maximum torque for a thread engagement (C) of 3.6 mm between screws and mounting threads.

Adapting maximum torque values

This is a general example. Use the corresponding values for your camera. The total screw length composes of the mounting holes length and the height of your mounting base. For using less than the recommended length of thread engagement, calculate maximum torque as follows:

$$\frac{\text{Current length of thread engagement}}{\text{Length of thread engagement in table}} \times \text{Torque in table} = \text{Current torque}$$

Example for a length of thread engagement of **1.4 mm** instead of 1.7 mm:
1.4 mm / 1.7 mm × 0.17 Nm = 0.14 Nm

Thread group	Thread position	Thread type	Total protrusion	Length of thread engagement	Maximum torque
d	Front mounting	M2	2 mm	1.7 mm	0.17 Nm
d	Front mounting	M2	2 mm	1.4 mm	0.14 Nm

Table 127: Adjusting maximum torque values

To ensure that the screws do not become loose over time, we recommend you to use means for securing screws, such as screw locking varnish.



Tripod adapter

For more information, see www.alliedvision.com/en/products/accessories.

Mounting the lens

Observe the following notes before you mount lenses to Alvim CSI-2 cameras.



CAUTION

Injury by falling cameras or lenses

A falling camera or lens can cause injury.

- Ensure proper mounting of cameras and lenses, especially for dynamic applications.
- Mount cameras as described in the instructions.
- Use a lens support for heavy lenses.



CAUTION

Risk of cuts by sharp edges of lens mounts

The threads of the lens mount can have sharp edges.

Be careful when mounting or unmounting lenses.

NOTICE
Damage to sensor, optics, or electronics by unsuitable lenses

The sensor, filter, lens, or electronics can be damaged if a lens exceeding maximum protrusion is mounted to the camera.

- Use lenses only up to the specified maximum protrusion, see [Maximum protrusion for front mounts](#) on page 202.
- S-Mount lenses must be screwed into the camera at less than maximum protrusion (11.0 mm), see [Mounting and focusing S-Mount lenses](#) on page 243.
- Avoid short S-Mount lenses falling into the camera.

Mounting and focusing S-Mount lenses

Allied Vision S-Mount lenses

For technical data of Allied Vision S-Mount lenses with dedicated operating instructions, see the S-Mount Lenses User Guide at www.alliedvision.com/fileadmin/content/documents/products/accessories/lenses/Allied_Vision/User_Guide/S-Mount-Lenses_User-Guide.pdf.

This section instructs how to use S-Mount lenses with your camera safely.

S-Mount lenses are screwed into the mount to adjust focus. Vibration moves lenses out of position. Several techniques can be used to fasten S-Mount lenses in focus. We recommend using fixing nuts. See instructions in this section.

Drawings and fixing nuts

Drawings in the instructions are schematic.

Several manufacturers offer various types of S-Mount fixing nuts. The type shown in the instructions drawings is an example.

We recommend using pinch nose pliers to tighten fixing nuts.

Figure 91 shows how fixing nuts lock S-Mount lenses. Follow the instructions to lock the lens in focus position.

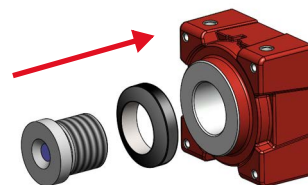

Figure 91: Fixing nut locking an S-Mount lens

NOTICE
Damage to sensor, optics, or electronics by improper handling

If an S-Mount lens is screwed against the sensor or electronics, sensor, lens, or electronics can be damaged.

- Screw in the lens at less than 11.0 mm maximum protrusion.
- Follow the instructions carefully.

Determining the allowed range for the position of the lens

1. Measure the length of the lens.
2. Calculate: $a = c - b$
 a: length of the mounted lens, measured from lens mount front flange
 b: maximum protrusion (11.0mm)
 c: length of the lens

See [Maximum protrusion for front mounts](#) on page 202.

3. Set a gauge to the length of (a).

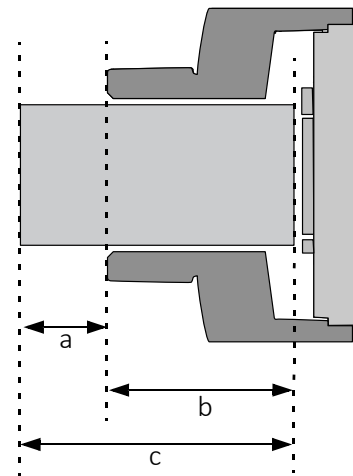

Figure 92: S-Mount lens and protrusion

Mounting the fixing nut to the lens

4. Screw the fixing nut clockwise onto the lens until you can hold the front part (d) of the lens with your finger tips.



Figure 93: Lens and fixing nut

Focusing the lens

5. **Checking (a) with a gauge**, slowly screw the lens clockwise into the lens mount until the image is roughly in focus.
6. Slowly screw in and unscrew the lens until you have found the most accurate focus.

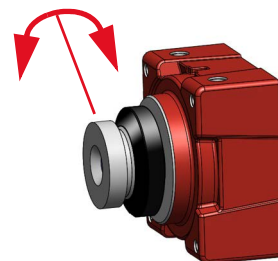

Figure 94: Adjusting focus

NOTICE
Damage to lens threads and fixing nut by excessive force

If the fixing nut is screwed with too much force, threads are worn out and the lens cannot be locked anymore.

Screw fixing nuts hand tight to keep the lens in a fixed position.

Locking focus

Pinch nose pliers are used to screw the fixing nut:

7. Holding the lens in position with one hand, screw the fixing nut clockwise against the lens mount until you feel the lens is locked.

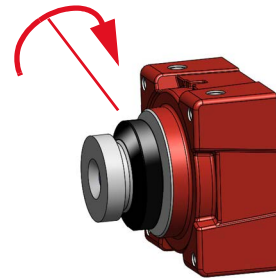

Figure 95: Tightening the fixing nut

Checking focus is set and locked properly

8. Check No.1: Try to rotate the lens with little force in both directions to ensure the lens is safely locked in position.

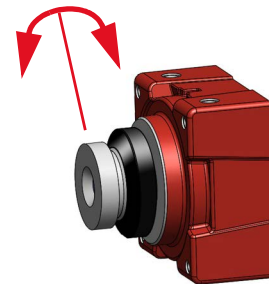

Figure 96: Checking lens is safely locked

9. Check No. 2: S-Mount thread allows a slightly tilted lens position. In this case, focus for a common object plane varies over the image plane.

If focus is constant over the image plane, you are done.

If focus varies over the image plane, the lens is tilted. Continue with 10.

10. Loosen the fixing nut.

11. Continue with 6.

The lens is locked in focus and ready for operation.

Camera interfaces

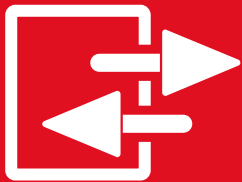

This chapter includes:

Standard Alvium and Alvium Frame: Connections	247
Alvium Flex: Connections	250
All Alvium CSI-2: Connections	253

Standard Alvium and Alvium Frame: Connections

Recommended accessories



Compatible electronics accessories

For more information, see www.alliedvision.com/en/products/accessories.

Back panel

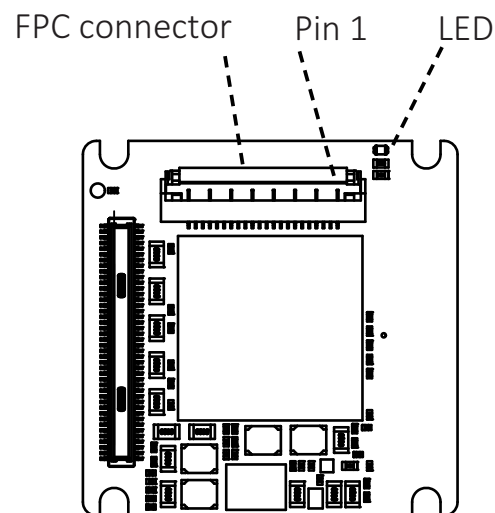

Figure 97: Standard Alvium and Alvium Frame camera back panel

For connector pin assignment, see [Hirose FH55 connector pin assignment](#) on page 248.

Hirose FH55 connector pin assignment

Standard Alvium CSI-2 cameras have a 22-pin Hirose FH55-22S-0.5SH connector.



NOTICE

Damage to the camera by reverse polarity

If Alvium CSI-2 cameras or camera I/Os are powered with reverse polarity, camera electronics can be damaged.

Observe polarity for camera and I/O power.



NOTICE

Damage by serial communication voltage levels

If you are using serial communication (UART, similar to RS232), keep voltage levels in the range defined in [Table 128](#) on page 249. Typical RS232 voltage levels (such as ± 10 VDC) are not supported without external circuitry.



More information on Hirose FH55-22S-0.5SH connector

For technical data and more instructions on the Hirose FH55-22S-0.5SH connector, see the manufacturer data sheet at www.hirose.com.

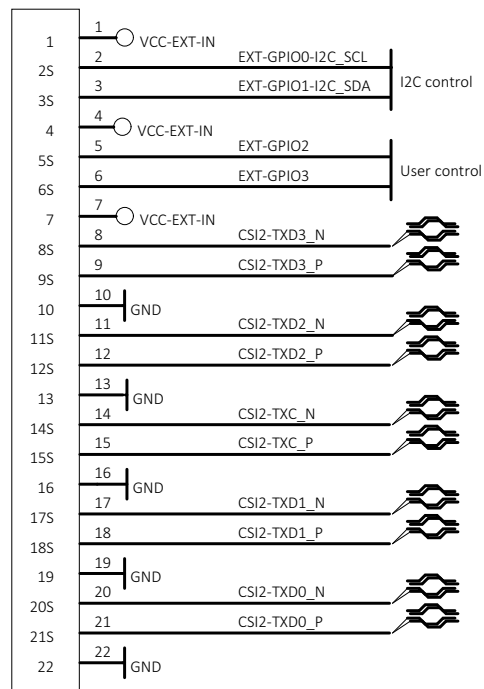

Figure 98: Standard Alvium and Alvium Frame - Hirose FH55-22S-0.5SH connector pin assignment

Pin	Signal	Direction	Level	Description
1	VCC-EXT-IN	PWR IN	4.5 to 5.5 VDC	Power supply voltage Maximum input current: 1.5 A
2	EXT-GPIO0-I2C_SCL	IN/OUT	$U_{in} (low) = -0.3$ to 0.8 VDC $U_{in} (high) = 2.0$ to 5.5 VDC $U_{out} (low) = 0$ to 0.4 VDC $U_{out} (high) = 2.4$ to 3.3 VDC at 12 mA	I2C Control Internal pull-up resistor: 33 to 63 k Ω
3	EXT-GPIO1-I2C_SDA	IN/OUT	See Pin 2, EXT-GPIO0	
4	VCC-EXT-IN	PWR IN	4.5 to 5.5 VDC	Power supply voltage Maximum input current: 1.5 A
5	EXT-GPIO2	IN/OUT	$U_{in} (low) = -0.3$ to 0.8 VDC $U_{in} (high) = 2.0$ to 5.5 VDC $U_{out} (low) = 0$ to 0.4 VDC $U_{out} (high) = 2.4$ to 3.3 VDC at 12 mA	GPIO Internal pull-up resistor: 33 to 63 k Ω
6	EXT-GPIO3	IN/OUT	See Pin 5, EXT-GPIO2	
7	VCC-EXT-IN	PWR IN	4.5 to 5.5 VDC	Power supply voltage Maximum input current: 1.5 A
8	CSI2-TXD3_N	OUT	According to MIPI CSI-2 D-PHY V1.1	CSI-2 TX data lane 3 negative rail
9	CSI2-TXD3_P	OUT	According to MIPI CSI-2 D-PHY V1.1	CSI-2 TX data lane 3 positive rail
10	GND	PWR	0 VDC	Power supply ground
11	CSI2-TXD2_N	OUT	According to MIPI CSI-2 D-PHY V1.1	CSI-2 TX data lane 2 negative rail
12	CSI2-TXD2_P	OUT	According to MIPI CSI-2 D-PHY V1.1	CSI-2 TX data lane 2 positive rail
13	GND	PWR	0 VDC	Power supply ground
14	CSI2-TXC_N	OUT	According to MIPI CSI-2 D-PHY V1.1	CSI-2 TX clock lane negative rail
15	CSI2-TXC_P	OUT	According to MIPI CSI-2 D-PHY V1.1	CSI-2 TX clock lane positive rail
16	GND	PWR	0 VDC	Power supply ground
17	CSI2-TXD1_N	OUT	According to MIPI CSI-2 D-PHY V1.1	CSI-2 TX data lane 1 negative rail
18	CSI2-TXD1_P	OUT	According to MIPI CSI-2 D-PHY V1.1	CSI-2 TX data lane 1 positive rail
19	GND	PWR	0 VDC	Power supply ground
20	CSI2-TXD0_N	OUT	According to MIPI CSI-2 D-PHY V1.1	CSI-2 TX data lane 0 negative rail
21	CSI2-TXD0_P	OUT	According to MIPI CSI-2 D-PHY V1.1	CSI-2 TX data lane 0 positive rail
22	GND	PWR	0 VDC	Power supply ground

Table 128: Standard Alvium and Alvium Frame - Hirose FH55-22S-0.5SH pin assignment

Alvium Flex: Connections

Observe for DF40C-50DP-0.4V connectors

Because using the Hirose DF40C-50DP-0.4V connector on Alvium Flex cameras is a novelty, no standard can be applied for the pinning. Therefore, connect your individual electronic parts only if you are an electronics expert. Otherwise, we recommend you to use boards and cables offered by Allied Vision for testing and evaluation, but also for final applications.



Alvium Flex accessories

See the Alvium Flex Design and Accessory Guide at www.alliedvision.com/en/support/technical-documentation/alvium-csi-2-documentation.

Back panel

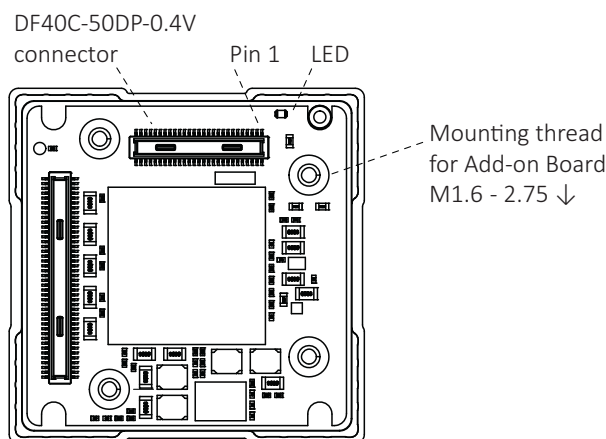

Figure 99: Alvium Flex camera back panel

DF40C-50DP-0.4V connector details

Alvium CSI-2 Flex cameras have a 50-pin Hirose DF40C-50DP-0.4V connector.



NOTICE

Damage to the camera by reverse polarity

If Alvium CSI-2 cameras or camera I/Os are powered with reverse polarity, camera electronics can be damaged.

- Use Alvium Flex accessories by Allied Vision.
- Observe polarity for camera and I/O power.

NOTICE
Damage by serial communication voltage levels

If you are using serial communication (UART, similar to RS232), keep voltage levels in the range defined in [Table 128](#) on page 249. Typical RS232 voltage levels (such as ± 10 VDC) are not supported without external circuitry.

More information on Hirose DF40C-50DP-0.4V connector

- For instructions and electronic specifications of Alvium Flex accessories, see the Alvium Flex Design and Accessory Guide at www.alliedvision.com/en/support/technical-documentation/alvium-csi-2-documentation.
- For technical data and more instructions on the Hirose DF40C-50DP-0.4V connector, see the manufacturer data sheet at www.hirose.com.

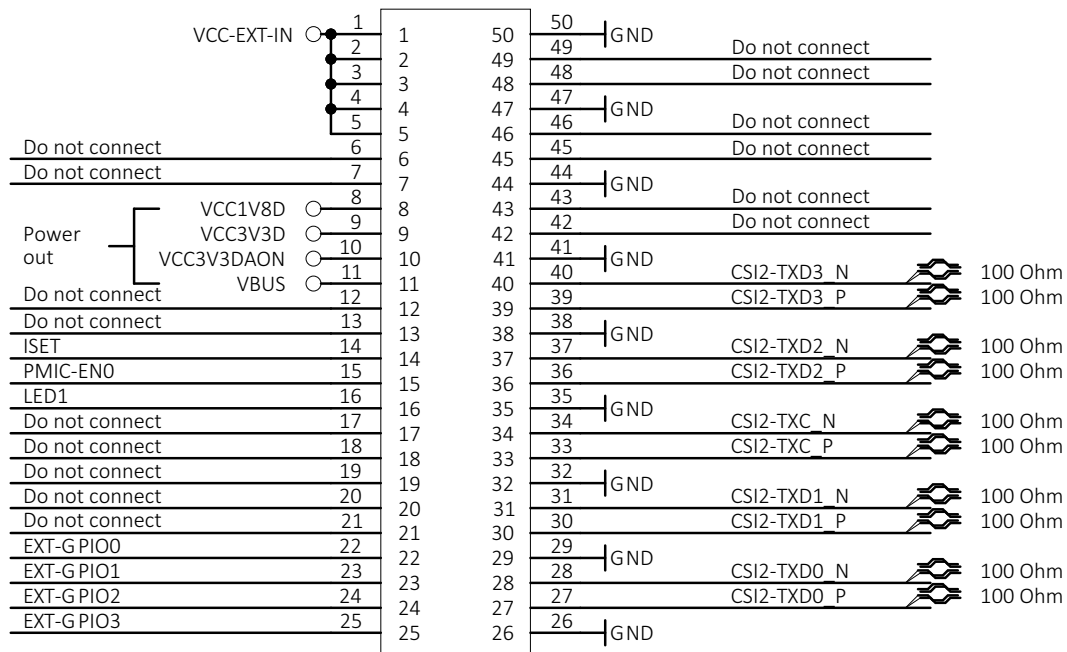

Figure 100: Hirose DF40C-50DP-0.4V connector pin assignment

Pin	Signal	Direction	Level	Description
1 to 5	VCC-EXT-IN	PWR IN	4.5 to 5.5 VDC	Power supply voltage Maximum input current: 1.5 A
6				Do not connect
7				Do not connect
8	VCC1V8D	PWR OUT	max. 1.8 VDC	Power output
9	VCC3V3D	PWR OUT	max. 3.3 VDC	Please contact Allied Vision Support if you want to use PWR OUT.
10	VCC3V3DAON	PWR OUT	max. 3.3 VDC	

Only signals shown in green must be connected for basic camera operation.

Table 129: Hirose DF40C-50DP-0.4V connector pin assignment (sheet 1 of 3)

Pin	Signal	Direction	Level	Description
11	VBUS	PWR OUT	4.0 to 5.5 VDC	Power output Please contact Allied Vision Support if you want to use PWR OUT.
12	Do not connect			
13	Do not connect			
14	ISET	IN	Not applicable	To increase the camera's default internal current limit of 900 mA, connect an 820 Ω resistor to GND.
15	PMIC-ENO	IN	$U_{in} \text{ (low)} = -0.3 \text{ to } 0.4 \text{ VDC}$ $U_{in} \text{ (high)} = 1.4 \text{ to } 5.5 \text{ VDC}$	Camera power supply enable switch (active high, internal 100 kΩ pull-up resistor, default on)
16	LED1	OUT	3.3 VDC at 4 mA	Status LED output
17	Do not connect			
18	Do not connect			
19	Do not connect			
20	Do not connect			
21	Do not connect			
22	EXT-GPIO0- I2C_SCL	IN/OUT	$U_{in} \text{ (low)} = -0.3 \text{ to } 0.8 \text{ VDC}$ $U_{in} \text{ (high)} = 2.0 \text{ to } 5.5 \text{ VDC}$ $U_{out} \text{ (low)} = 0 \text{ to } 0.4 \text{ VDC}$ $U_{out} \text{ (high)} = 2.4 \text{ to } 3.3 \text{ VDC}$ at 12 mA	I2C Control Internal pull-up resistor: 33 to 63 kΩ
23	EXT-GPIO1- I2C_SDA	IN/OUT		See Pin 22, EXT-GPIO0
24	EXT-GPIO2	IN/OUT	$U_{in} \text{ (low)} = -0.3 \text{ to } 0.8 \text{ VDC}$ $U_{in} \text{ (high)} = 2.0 \text{ to } 5.5 \text{ VDC}$ $U_{out} \text{ (low)} = 0 \text{ to } 0.4 \text{ VDC}$ $U_{out} \text{ (high)} = 2.4 \text{ to } 3.3 \text{ VDC}$ at 12 mA	GPIO Internal pull-up resistor: 33 to 63 kΩ
25	EXT-GPIO3	IN/OUT		See Pin 24, EXT-GPIO2
26	GND	PWR	0 VDC	Power supply ground
27	CSI2-TXD0_P	OUT	According to MIPI CSI-2 D-PHY V1.1	CSI-2 TX data lane 0 positive rail
28	CSI2-TXD0_N	OUT		CSI-2 TX data lane 0 negative rail
29	GND	PWR	0 VDC	Power supply ground
30	CSI2-TXD1_P	OUT	According to MIPI CSI-2 D-PHY V1.1	CSI-2 TX data lane 1 positive rail
31	CSI2-TXD1_N	OUT		CSI-2 TX data lane 1 negative rail
32	GND	PWR	0 VDC	Power supply ground
33	CSI2-TXC_P	OUT	According to MIPI CSI-2 D-PHY V1.1	CSI-2 TX clock lane positive rail
34	CSI2-TXC_N	OUT		CSI-2 TX clock lane negative rail
35	GND	PWR	0 VDC	Power supply ground
36	CSI2-TXD2_P	OUT	According to MIPI CSI-2 D-PHY V1.1	CSI-2 TX data lane 2 positive rail
37	CSI2-TXD2_N	OUT		CSI-2 TX data lane 2 negative rail
38	GND	PWR	0 VDC	Power supply ground
39	CSI2-TXD3_P	OUT	According to MIPI CSI-2 D-PHY V1.1	CSI-2 TX data lane 3 positive rail
40	CSI2-TXD3_N	OUT		CSI-2 TX data lane 3 negative rail

Table 129: Hirose DF40C-50DP-0.4V connector pin assignment (sheet 2 of 3)



Pin	Signal	Direction	Level	Description
41	GND	PWR	0 VDC	Power supply ground
42				Do not connect
43				Do not connect
Only signals shown in green must be connected for basic camera operation.				
45				Do not connect
46				Do not connect
47	GND	PWR	0 VDC	Power supply ground
48				Do not connect
49				Do not connect
50	GND	PWR	0 VDC	Power supply ground
Only signals shown in green must be connected for basic camera operation.				

Table 129: Hirose DF40C-50DP-0.4V connector pin assignment (sheet 3 of 3)

All Alvium CSI-2: Connections

Signal	LineSelector (GenICam)	UART line
EXT-GPIO 0	Line0	Not applicable
EXT-GPIO 1	Line1	Not applicable
EXT-GPIO 2	Line2	UART Tx
EXT-GPIO 3	Line3	UART Rx

Table 130: Value settings to control I/Os using the LineSelector feature

Feature descriptions
 <p>For more information in LineSelector and SerialHub features, see the Alvium Features Reference at www.alliedvision.com/en/support/technical-documentation/alvium-csi-2-documentation.</p> 

Non-isolated, programmable GPIOs



Available GPIOs

From four GPIOs, I2C uses two GPIOs for control traffic. Therefore, only two GPIOs are available for user control of the camera.



I/O cables maximum length

The maximum length for I/O cables must not exceed 30 m.

GPIOs description

The camera has four non-isolated GPIOs that can be configured by software to act as inputs or outputs.

Alvium GPIOs use the push-pull technology to switch the signal level between low and high. For low levels, the signal is "pulled" down towards ground level. For high levels, the signal is "pushed" up towards VCC level.

Alvium GPIOs feature the CMOS push-pull output drivers and Schmitt trigger inputs with an internal pull-up resistor and a filter circuit, shown in [Figure 101](#). The push-pull GPIOs are able to source or sink current from an external pin.

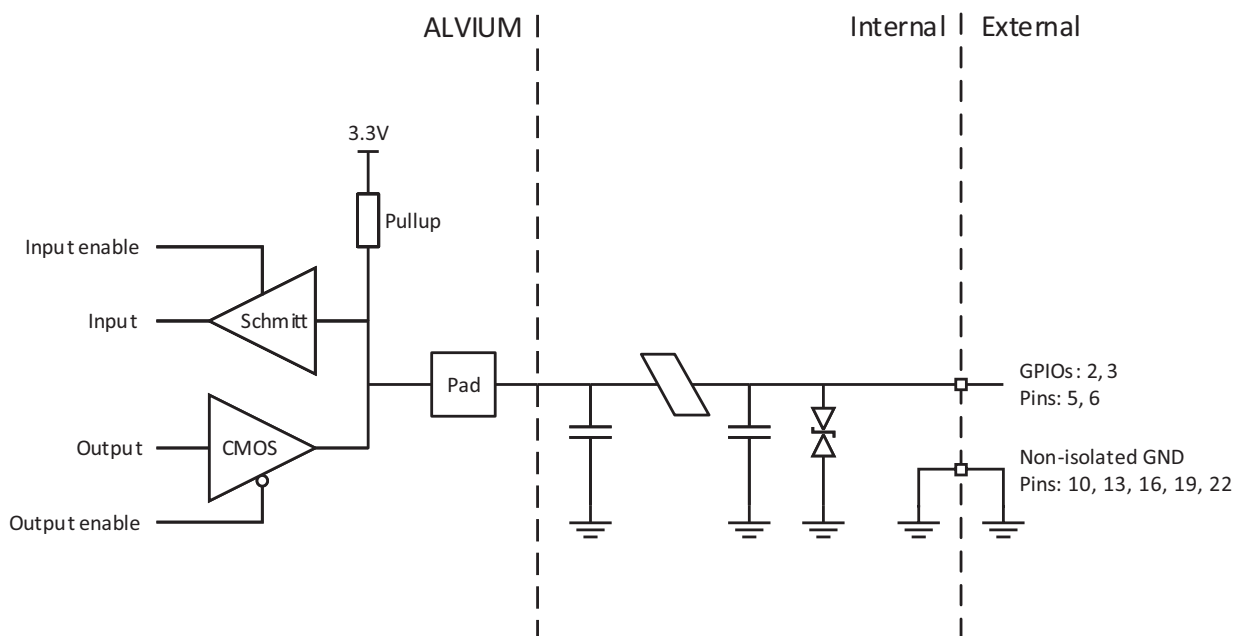

Figure 101: GPIOs block diagram

Input levels

The GPIOs can be connected directly to the system controlling the camera for voltages up to 5.5 VDC. An external resistor is not necessary.



NOTICE

Damage to the camera by high input voltage

Exceeding maximum input voltage can damage the camera.

Keep maximum input voltage below 5.5 VDC.

Parameter	Value
U_{in} (low)	-0.3 to 0.8 VDC
U_{in} (high)	2.0 to 5.5 VDC
Undefined levels	0.8 to 2.0 VDC

Table 131: GPIOs as input, voltage levels

Output levels



NOTICE

Damage to the camera by high output current or voltage

The camera can be damaged when connected to a device that exceeds the specified maximum current or voltage. Consider maximum values:

- Max. current = 12 mA per output
- Max. Out VCC = 3.3 VDC

Parameter	Value
External output voltage U_{out} (low)	0 to 0.4 VDC
External output voltage U_{out} (high)	2.4 to 3.3 VDC
Undefined levels	0.4 to 2.4 VDC
Maximum external output voltage	3.3 VDC
Maximum output current	12 mA

Table 132: GPIOs as output, current and voltage levels



Output voltage for U_{Out} (high) = On state

The voltage level in the On state depends on the load current. Higher currents yield lower voltage.

Status LED

Alvium CSI-2 cameras have a green status LED. The following table describes the flashing pattern indicating different events. Inverse flashing: If the LED is already on, it is switched off for a short time.

Normal operation



LED codes	Behavior	Status
	Continuously active	Power on or idle state
	Irregular flashing	Command or image traffic, such as for camera startup
	Four short flashes and code sequence	Error state

Table 133: LED codes for normal operation

Error conditions

Four short flashes followed by another sequence indicate errors. In this case, try the following to get the camera back to normal operation:

1. Restart the camera.
2. If the LED again indicates error state after restart, please contact support at www.alliedvision.com/en/about-us/contact-us/technical-support-repair/-rma.

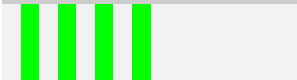
Triggering



This chapter includes:

Availability of triggering controls for CSI-2	258
Trigger signal flow	258
Trigger latency	259
Triggering with rolling shutter cameras	259

Availability of triggering controls for CSI-2

Alvium CSI-2 cameras can be triggered by all embedded boards supported by Alvium CSI-2 cameras.



Downloads

Some boards have limitations. For more information, go to the examples repository on <https://github.com/alliedvision>.

Use the NVIDIA Jetson driver provided at https://github.com/alliedvision/linux_nvidia_jetson



Trigger controls description

For more information on triggering controls, see the Alvium CSI-2 Register Controls Reference at www.alliedvision.com/en/support/technical-documentation/alvium-csi-2-documentation.

The current firmware supports Frame Start Trigger controls by software or external line signals. Other trigger controls known from GenICam features are not supported.

Some controls may not be supported by all camera models.

Trigger signal flow

Figure 102 shows an ideal diagram for the trigger signal flow for Alvium CSI-2 cameras. The external signal can be a physical source, such as light barrier as hardware trigger or a software trigger. This external signal starts the exposure of a frame. The end of exposure starts the readout. High levels show the active state of a signal. The different **signals display the workflow**, not user controls.

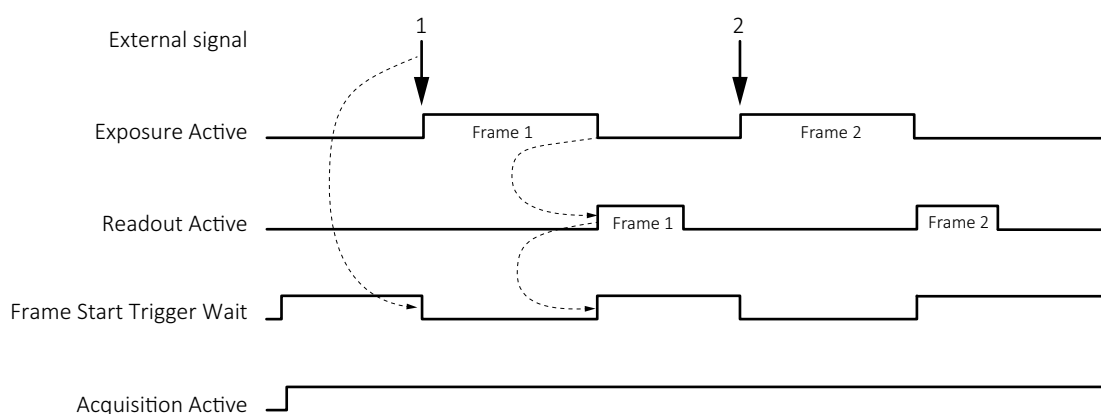

Figure 102: Trigger signal flow

Term	Description
External signal	Electrical trigger signal starting the signal flow
Exposure Active	Exposing a frame
Readout Active	Reading out a frame
Frame Start Trigger Wait	Waiting for a trigger
Acquisition Active	Enables frame acquisition: Expose, read out data, or wait for triggers.

Table 134: Trigger signal flow, legend

Trigger latency

In theory, a trigger creates an immediate response of the camera, depending on the cable length. In practice, the computer may add a delay that is mostly unpredictable. In addition, camera electronics and sensors have a delay.

Rolling shutter (RS) cameras in this document also have exposure delay, depending on camera settings, see [Triggering with rolling shutter cameras](#) on page 259.



Trigger features and UserSetDefault

See [Trigger features and UserSetDefault](#) on page 207.

Triggering with rolling shutter cameras

This section describes triggering behavior for **1500 C-210m/c** and **C-500m/c**, and for **1800 C-1240m/c** and **C-2050m/c**. [Figure 103](#) shows how an external signal triggers exposure and readout for cameras with rolling shutter (RS) sensors. Like for global shutter (GS) sensors, readout has a constant duration, acquisition must be active to enable exposure, the end of exposure starts readout.

Rolling shutter (RS) sensors run in cycles where [readout area](#) equals [exposure area](#). Overlapping triggering is not supported. If exposure time is shorter than readout time, exposure starts with a delay:

Exposure start delay = exposure area – exposure time.



Signals and controls

The signals displayed in Figure 103 represent logical states, not user controls.

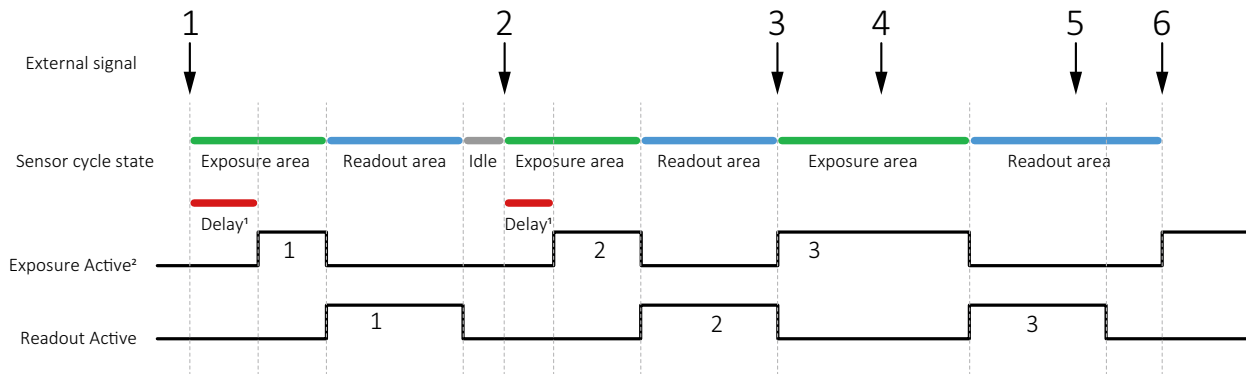

¹Exposure start delay

²Active when all lines are exposing simultaneously. Therefore, Exposure Active is shorter than Exposure Time.

Figure 103: Triggering rolling shutter (RS) cameras

No	Conditions	Results
1	Exposure time is shorter than readout time.	Trigger 1 starts exposure 1 with a delay
2	Exposure time is shorter than readout time, but longer than for exposure 1.	Trigger 2 starts exposure 2 with a delay shorter than for exposure 1.
3	Exposure time is longer than readout time	Trigger 3 starts exposure time without a delay. Because the exposure area is longer, also the readout area is longer than for triggers 1 and 2
4	Exposure area is ongoing.	Trigger 4 is ignored.
5	Readout area is ongoing	Trigger 5 is ignored.
6	Readout area is finished. Exposure time is longer than readout time.	Trigger 6 starts exposure 6 without a delay

Table 135: Triggering conditions and results

TriggerSelector values for rolling shutter (RS) cameras

Cameras with rolling shutter (RS) **can** be triggered using *AcquisitionStart*, *AcquisitionEnd*, or *FrameStart* for TriggerSelector.

Cameras with rolling shutter (RS) **cannot** be triggered using *ExposureStart* or *ExposureEnd* for TriggerSelector.



Frame rates in triggered mode

When rolling shutter cameras are operated in triggered mode, the values for maximum frame rate reached in free run mode are cut in half.

Ignored triggers

Alvium 1500 C-210m/c, C-500m/c, 1800 C-1240m/c, 1800 C-2050m/c

Changing parameters while acquisition is active leads to ignored triggers until the parameters get active.

Trigger delay with 1500 C-120 cameras

If sensor related parameters are changed **directly before** sending an external trigger, the trigger delay can be increased. This relates to [Frame rate jitter](#) on page 271.

Firmware update



This chapter describes how firmware is updated on Alvium CSI-2 cameras:

Please note.....	263
Preparing firmware updates	263
Updating the firmware.....	264
Error handling	266

Please note

You should update firmware only to change camera functions or fix known issues.

Consider: Any firmware update may not only add new features to a camera or fix known issues. It may also replace previous features or change camera characteristics. See firmware release notes for details.



Keep the camera connected

- Keep the camera and the computer running while you are executing a firmware update.
- If the camera is powered down during firmware update, the camera firmware may get into a non-functional state.



Use only suitable firmware

If unsuitable firmware is used, the camera may get into a non-functional state.

- Only update to newer versions. Do not downgrade firmware to an older version, unless this has been explicitly communicated.
- We recommend updating the firmware to the next increment version only. Skipping versions may cause issues.

Preparing firmware updates

1. Download and install **Vimba X**.
The download includes **Vimba X** documentation.
2. Download the firmware (AVF file).



Downloads

- For **Vimba X**, see www.alliedvision.com/en/products/software/vimba-x-sdk.
- For firmware updates, see www.alliedvision.com/en/support/firmware.

3. Connect your Alvim camera to the embedded board.
4. Execute ELF file of the firmware updater.
The **Vimba X Firmware Updater** window opens, displaying your camera and the installed firmware version.
5. Continue with [Updating the firmware](#) on page 264.

Updating the firmware



Screenshots

The following instruction shows the firmware update on a **Linux** system. On **Linux** systems with other skins and on **Windows**, the GUI will look different.

If you are using command lines, you can derive the workflow from this instruction.

1. Click **Open** to select the firmware for the update.

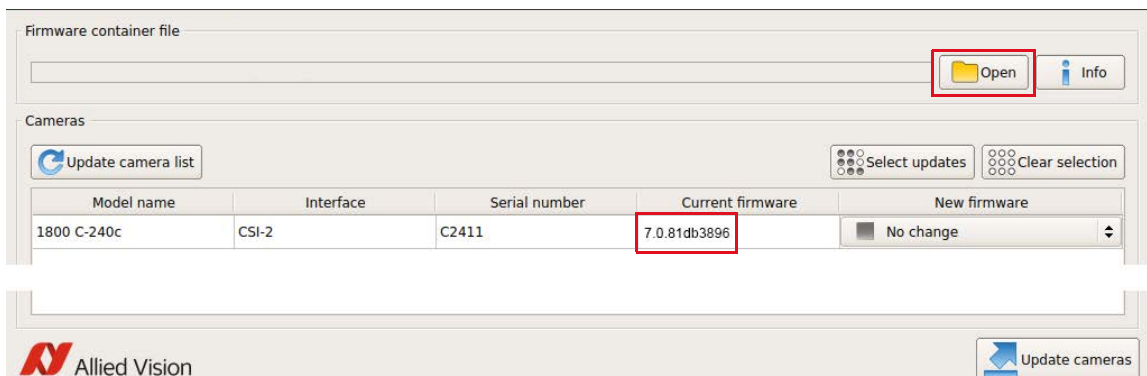

Figure 105: The camera and installed firmware are displayed

2. Select the firmware for the update from the drop-down menu.

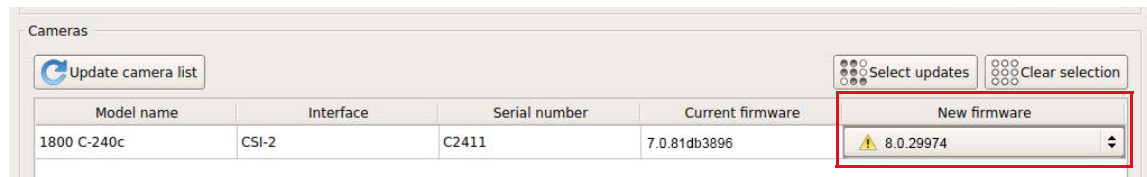

Figure 106: The firmware version is selected

3. Click **Update cameras**.

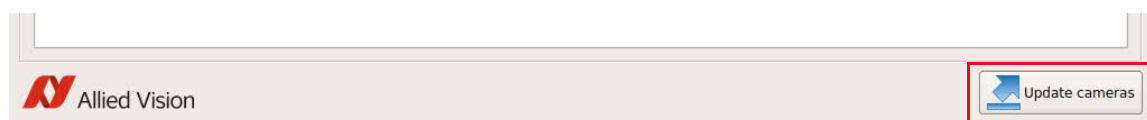

Figure 107: The update is being prepared

- Click **OK** to confirm.



Figure 108: The command to update the firmware is confirmed

The update progress is displayed.

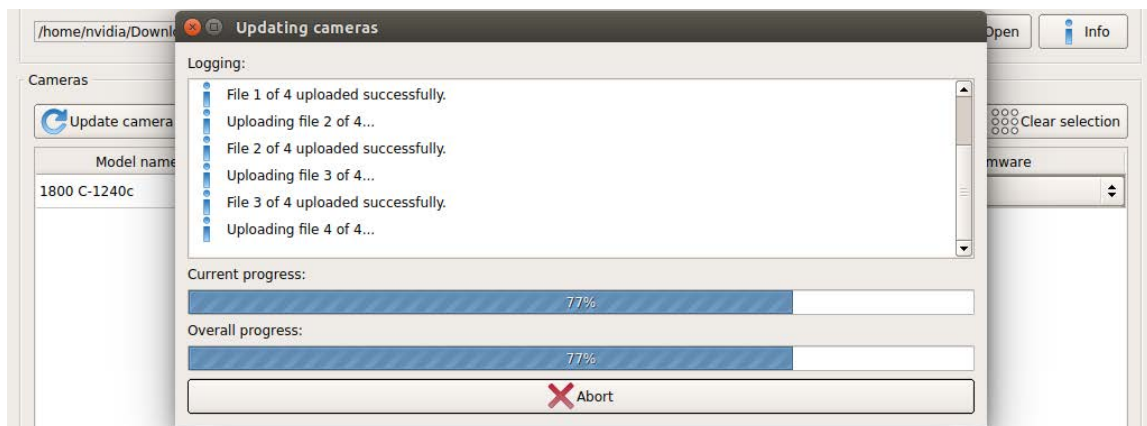

Figure 109: The update progress is displayed

- Click **Close** to confirm the completion of the update.

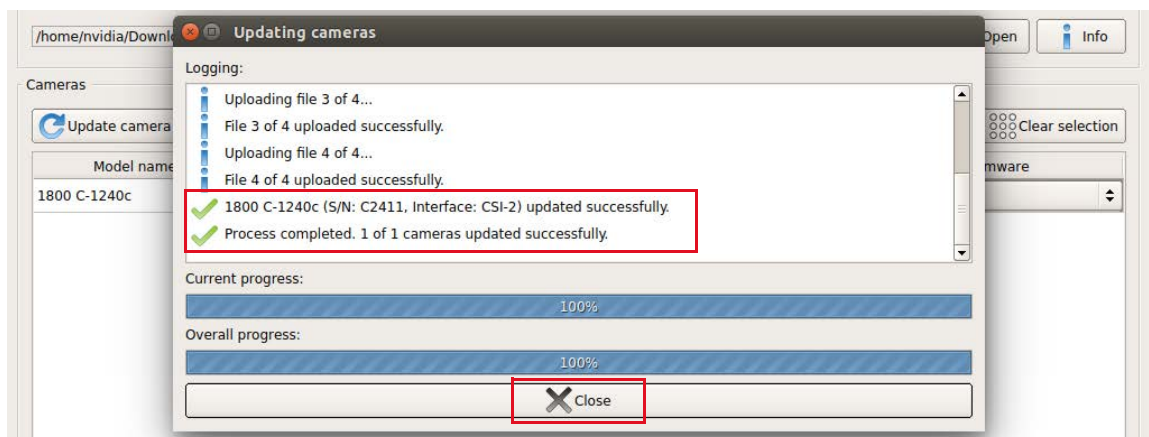

Figure 110: The update has been successfully completed

The camera is displayed with the updated firmware version.

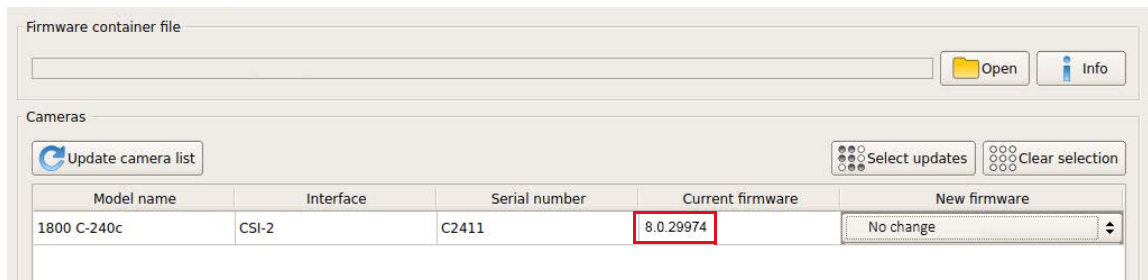

Figure 111: The updated firmware version is displayed

Error handling

If firmware update fails,

- The camera is shown as “Fallback” on the CSI-2 interface.
- The camera is recognized by viewer applications but can not be used for streaming.
- You can repeat the firmware update.

Should the firmware update not succeed, please contact support at www.alliedvision.com/en/about-us/contact-us/technical-support-repair-/-rma.

Image data flow

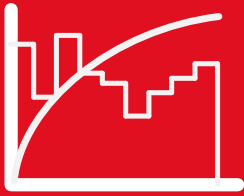

This chapter includes an image data flow of Alvium CSI-2 cameras.

Figure 112 shows image data processing in Alvim CSI-2 cameras in general.

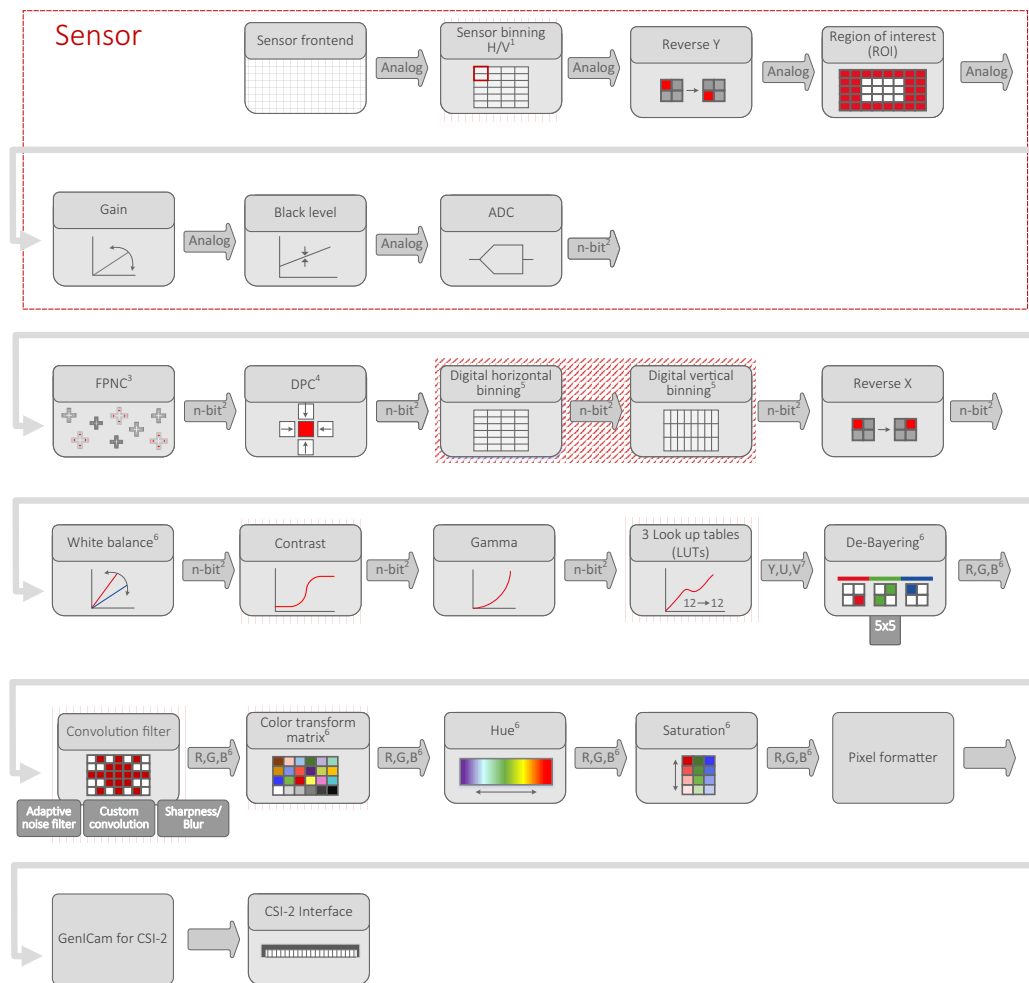

||| **GenICam for CSI-2 Access** only (all Alvim 1800 C models)

/// **GenICam for CSI-2 Access / Direct Register Access:** Different behavior

¹ Selected models only: See tables in [Specifications](#) on page 60

² Model dependent: See ADC bit depths in [Specifications](#) on page 60.

³ Factory preset for FPNC = Fixed pattern noise correction. FPNC is **currently not supported** by Alvim 1800 C-030 VSWIR, -052, -130 VSWIR, -203, -234, -235, -291, -895, -2050.

⁴ Factory preset for DPC = Defect pixel correction

⁵ For **Direct Register Access:** Values for H and V are commonly adjusted.

⁶ Color models only

⁷ For monochrome models: Y only

Figure 112: Image data flow of Alvim CSI-2 cameras



Descriptions for controls and features

The shown functionalities represent controls or groups of controls:

- For V4L2 controls, see www.linuxtv.org.
- For register controls, see the Alvium CSI-2 Register Controls Reference. See www.alliedvision.com/en/support/technical-documentation/alvium-csi-2-documentation for details.
- For GenICam features, see the Alvium Features Reference. See www.alliedvision.com/en/support/technical-documentation/alvium-csi-2-documentation for details.

Performance



This chapter includes:

Image transfer with rolling shutter cameras	271
Frame rate jitter	271
Value changes by control interdependencies.....	272
Dark current compensation	274
Shutter types affecting image readout	276

Image transfer with rolling shutter cameras

Alvium 1500 C-210m/c, C-500m/c, 1800 C-1240m/c, and 1800 C-2050m/c

If acquisition is started and stopped in a short sequence, no image is transferred to the host. The duration cannot be predicted, because it depends on various factors.

Frame rate jitter

Alvium 1500 C-120m/c, C-210m/c, C-500m/c, 1800 C-1240m/c, 1800 C-2050m/c

Generally, some parameters can be changed during exposure without affecting the timing. For models with ON Semiconductor AR sensors and rolling shutter sensors, a different behavior must be considered for **camera operation in freerun mode without triggering**:

Changing parameters during exposure leads to frame rate jitter. When parameters are entered, the next frame starts only after readout and sensor reconfiguration delay are finished. When the camera is run in **ExposureAuto** mode, the actual frame rate is less than the calculated value for the corresponding exposure time. Consider frame rate jitter for your application, including a gap between **ExposureActive** signals.

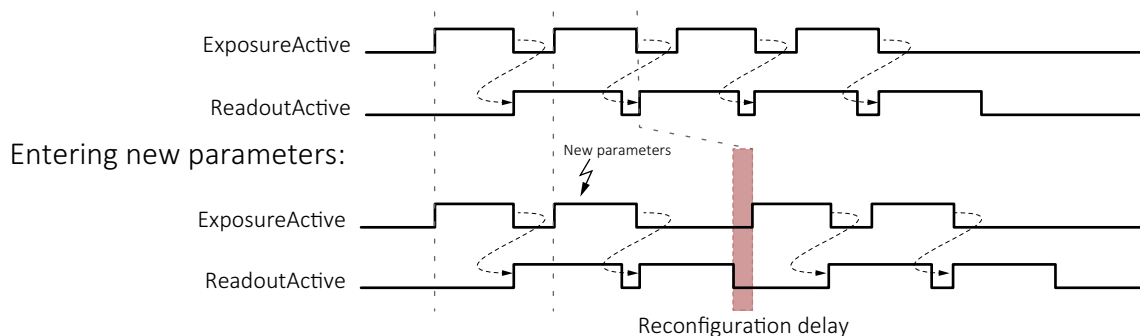

Figure 113: Delayed exposure due to parameter changes



Parameter changes in triggered mode

See [Ignored triggers](#) on page 261 for more information.

Value changes by control interdependencies

The conversion between time and clock cycles affects control values. Controls for pixel format, bandwidth, ROI, and exposure time are related to each other. Changing values for one control can change values for another control. For example, frame rates can be reduced when **MIPI Data Format** is changed subsequently. [Figure 114](#) shows the interdependencies.

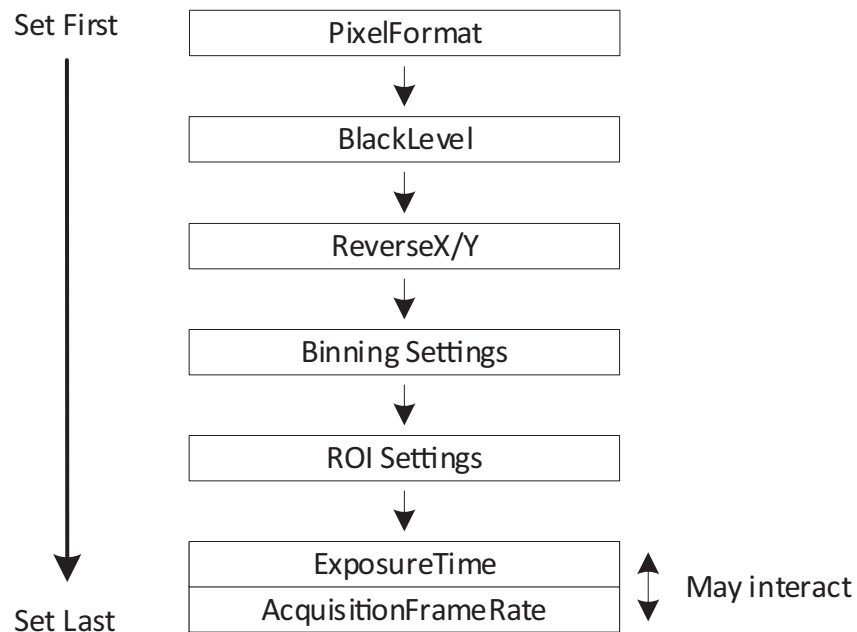

Figure 114: Interdependencies between controls

Effects for the interdependent controls

Changing one control's value affects other control's values, such as:

If: **Height** value is changed.

Then: Other values may be affected, such as for **ExposureTime**.

We recommend you to consider:

- The more controls you adjust, the more current values deviate from previously set values.
- The same effects that apply to **ExposureTime**, also apply to **ExposureAuto**.
- To avoid readjustments, apply settings in the order shown in [Figure 114](#).

Impact by other controls

Input	Output	
	Exposure time values	Frame rate
ExposureTime	Affected as expected	Affected
CSI-2LaneCount	Affected	Affected
Height	Not affected	Affected
Width	May be affected	May be affected

Table 136: Impact by other controls

Exposure times and frame rates with Sony IMX rolling shutter cameras

Alvium 1800 C-1240 m/c and C-2050m/c

Generally, long exposure times result in low frame rates because one is roughly the inverse of the other. With Alvium IMX RS cameras

- The range of available frame rates depends on the exposure time.
- The exposure time must be increased when low frame rates are used.
- The available range for frame rate values depends on the exposure time. If by changing the exposure time, the previous frame rate is moved out of the available range, the frame rate is adjusted automatically.

Dark current compensation

All sensors accumulate dark current in the pixels. Dark current increases the signal level and black level. Most sensors in Alvium CSI-2 cameras compensate for this.

For **Alvium 1500 C-050m/c** with the ON Semi PYTHON 480 sensor, see [Black level compensation for 1500 C-050m/c](#) on page 275.

If cameras are operated at high temperatures or exposure times, compensation reaches its limits. The typical compensation mechanism uses a **margin** to compensate for dark current. This works only until dark current reaches the size of the margin. The following table shows the relation of the margin and accumulated dark current for a pixel in 8-bit mode with a maximum value of 255.

Effective signal versus noise	Description
	<p>The pixel has accumulated no dark current, the margin has maximum size.</p>
	<p>The pixel has accumulated some dark current, reducing the size of the margin.</p>
<p>The following images show a pixel that has accumulated a higher dark current than the margin.</p>	
	<p>The pixel has accumulated dark current, the margin reduces to 0.</p> <p>Type 1 compensation</p> <ul style="list-style-type: none"> • Dark current compensation is stopped. • Dark current increases the black level. • Fixed pattern noise increases.
	<p>The pixel has accumulated dark current, the margin reduces to 0.</p> <p>Type 2 compensation (Typically used for sensor-internal compensation, often in the analog domain.)</p> <ul style="list-style-type: none"> • Dark current compensation stays active. • Maximum saturation signal decreases. • Fixed pattern noise increases.

Table 137: Accumulated dark current affecting the effective image signal

Additional compensation

If compensation limits are reached and you cannot decrease operating temperature or exposure time, what can you do to keep signal quality high?

Measures for type 1 compensation

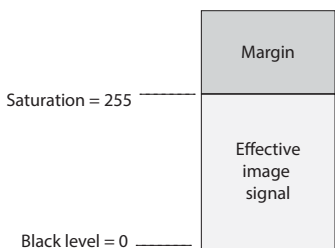
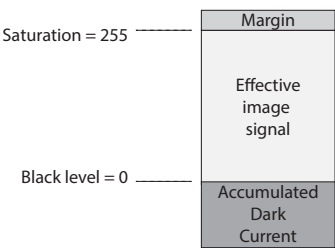
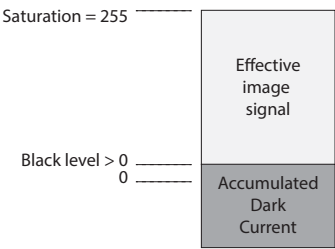
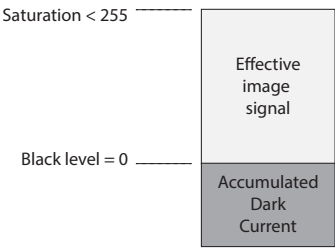
Alvium 1500 C-050m/c supports compensation type 1. For additional compensation, see [Black level compensation for 1500 C-050m/c](#) on page 275.

Typically, there is no measure to improve the image signal. The rising black level shifts black and dark gray values to gray.

Measures for type 2 compensation

All other Alvium camera models support compensation type 2.

You can increase the margin size by using gain, with the following side effects:

- To give space to a larger margin, the effective pixel capacity decreases.
- White and light gray values are shifted down to gray.

Black level compensation for 1500 C-050m/c



Because the ON Semi PYTHON 480 sensor does not have a dark current compensation, **Alvium 1500 C-050m/c** cameras have a typical black level value drift, depending on exposure time and **DeviceTemperature** (measured at the mainboard). [Table 138](#) shows the effect of the black level compensation. Should additional compensation be needed, we recommend cooling the camera.

Temperature [°C]	ExposureTime [ms]							
	1	10	50	100	250	500	750	1,000
35	Full	Full	Full	Full	Full	Full	Full	Full
40	Full	Full	Full	Full	Full	Full	Full	Full
45	Full	Full	Full	Full	Full	Full	Full	Full
50	Full	Full	Full	Full	Full	Full	Full	Full
55	Full	Full	Full	Full	Full	Full	Full	Full
60	Full	Full	Full	Full	Partial	Partial	Partial	Partial
65	Full	Full	Full	Partial	Partial	Partial	Partial	Partial
70	Full	Full	Partial	Partial	Partial	Partial	Partial	Partial
75	Full	Partial	Partial	Partial	Partial	Partial	Partial	Partial
Full compensation	Full compensation							
Partial compensation	Partial compensation							

Table 138: Exposure time and temperature affecting black level compensation

Shutter types affecting image readout

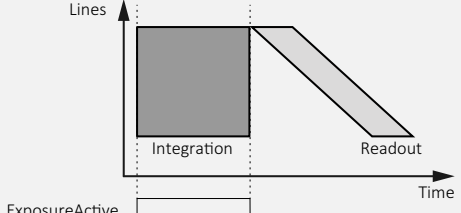
Most Alviium CSI-2 camera models are operated using global shutter (GS).

Property	Line readout	Moving image
Global shutter (GS)		

Alvium 1500 C-210, -500, and 1800 C-500 models use rolling shutter (RS).

Alvium 1800 C-1240 and -2050 models offer global reset shutter (GRS) in addition:



Property	Rolling shutter (RS)	Global reset shutter (GRS)
Line readout		
Line exposure start	Deferred from line to line	Common for all lines
Line exposure time	Common for all lines	Increases from line to line
Image acquisition of moving objects		
Image brightness	Constant over the image	Varying over the image
Moving objects	Distorted shape	Shape without distortion
Typical application	Static objects	Moving objects
Compensation	Use an additional mechanical shutter or	use a strobe light:
		

Table 139: Shutter types affecting image readout

Index

A

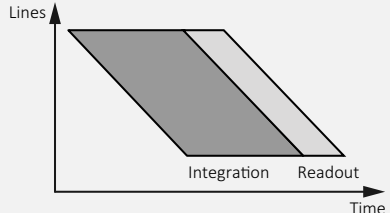
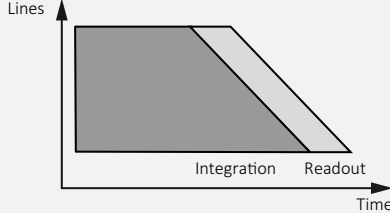
access modes	227
Allied Vision contact	22
Alvium Flex	
dimensions and mass	195
interface connection	250
overview	19
technical drawings	195
Alvium Frame	
aligning	240
camera mounting	241
dimensions and mass	200
installing	239
overview	21
sensor position accuracy	205
technical drawings	200
Alvium Frame Flex	
dimensions and mass	201
technical drawings	201

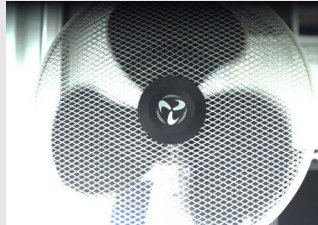
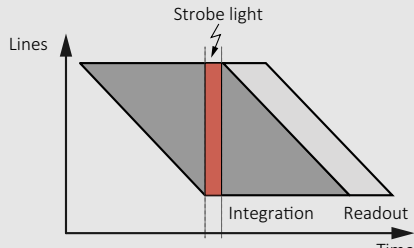
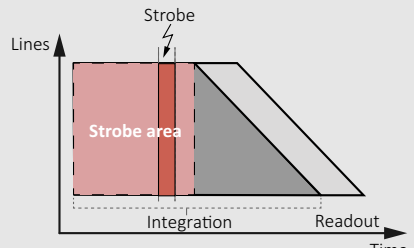
B

black level compensation	275
--------------------------------	-----

C

camera identification	
model ID	49
serial numbers	233
CE	49
China RoHs	49
compliance	49
connectors	246
control interdependencies	272

D

dark current compensation	274
digital binning	70
dimensions and mass	
Alvium Flex	195
Alvium Frame	200
Alvium Frame Flex	201
standard Alvium	189
Direct Register Access	227
document	
conventions	43

history	32
overview	15
terms	45
driver installation	232

E

ESD	54
ExposureMode and exposure times	67

F

feature availability	208
field of view	
vs. focal length	212
firmware update	262
flange focal distance	189
focal length	
vs. field of view	212
FPC connectors, pin assignment	248
frame rate	
jitter	271
reference settings	68
rolling shutter sensors	69
Sony IMX rolling shutter	273

G

GenICam	61
GenICam features	229
GenICam for CSI-2 Access	227
global shutter (GS)	276
GPIOs	
input levels	255
output levels	255
ground	248
ground loops	55

H

hardware assembly	
aligning Alvium Frame	240
camera mounting - Alvium Frame	241
camera mounting - bare board	237
camera mounting - open housed	238
FPC cable and FPC connectors	234
heat sink mounting	236
lens mounting	242
heat dissipation	52
Hirose F40C-50DP-0.4V description	250
Hirose FH55-22S-0.5SH description	248

I	
image data flow	268
image transfer with RS cameras	271
intended use	50
interfaces	246
IR cut filter	203
L	
lanes	248
LED	256
lenses	210
focal length vs. field of view	212
maximum protrusion	59
mounting	242
vignetting	211
M	
maximum protrusion	
safety	202
MIPI CSI-2	61
N	
naming	45
P	
pin assignment	248
power consumption	
reference settings	70
Q	
quantum efficiency	64
R	
readout modes	67
register controls	229
rolling shutter (RS)	276
S	
safety	2, 8, 51
bare board cameras	57
camera power	55
electrical connections	54
embedded systems	53
FPC cables	56
ground loops	55
heat dissipation	52
heat sinks	59
Hirose FH55 and DF40C-50DP-0.4V	55
Hirose FH55 FPC connectors	56
lens mounts	51
maximum protrusion	59
optical components	57
PCBAs	54
sensor	58
sensor binning	70
sensor handling	58
sensor position accuracy	204
shift and rotation with Alvium Frame	205
standard and Alvium Flex	204
SensorBitDepth	67
shock and vibration	61
S-Mount lenses	
focal length versus FOV	212
mounting	243
software installation	232
specifications	60
support	22
T	
technical drawings	
Alvium Flex	195
Alvium Frame	200
Alvium Frame Flex	201
standard Alvium	190
term definitions	45
triggering	257
troubleshooting	270
typical operation	70
U	
UART	253
user sets	207
V	
V4L2 controls	229
Video4Linux Access	227
W	
WEEE	49
white balance default	188