



Alvium

1800 C-030 VSWIR



- IMX991 VSWIR sensor
- ALVIUM image processing
- MIPI CSI-2 interface
- Various hardware options

Model without hardware options

Alvium 1800 C – High-performance camera modules for embedded vision

Machine vision sensors for embedded system developers

Alvium 1800 C-030 VSWIR with Sony IMX991 runs 223.0 frames per second at 0.3 MP resolution.

The powerful Alvium 1800 C MIPI CSI-2 camera series gives embedded system developers access to Sony’s high-performance image sensors popular in the machine vision industry. These sensors with resolutions up to 20 megapixels deliver excellent image quality and up to twice the frame rates compared to similar Alvium 1500 C models.

To operate Alvium CSI-2 cameras on your vision system, Allied Vision provides different access modes: - **Direct Register Access (DRA)** to control the cameras via registers for advanced users. - Video4Linux2 Access allows to control the cameras via established V4L2 API and applications like GStreamer and OpenCV. Open-source CSI-2 drivers are available on [GitHub](#) for different boards and system on chips (SoCs).

See [Customization and OEM Solutions webpage](#) for Alvium Cameras Hardware Options .

Specifications

Alvium 1800 C-030 VSWIR	
Interface	MIPI CSI-2, up to 4 lanes
Resolution	656 (H) × 520 (V)
Spectral range	400 to 1700 nm
Sensor	Sony IMX991

Alvium 1800 C-030 VSWIR

Sensor type	InGaAs
Shutter mode	Global shutter
Sensor size	Type 1/4 VSWIR
Pixel size	5 μm \times 5 μm
Lens mount (default)	C-Mount
Max. frame rate at full resolution	223 fps using 10-Bit mode
ADC	12 Bit
Image buffer (RAM)	256 KByte
Non-volatile memory (Flash)	1024 KByte

Output

Bit depth	Max. 12 Bit
Raw pixel formats	RAW8 (GREY), RAW10 (Y10), RAW12 (Y12) [MIPI CSI-2 (FOURCC)]

General purpose inputs/outputs (GPIOs)

TTL I/Os	2 programmable GPIOs
----------	----------------------

Operating conditions/dimensions

Operating temperature	-20 °C to +65 °C (housing)
Power requirements (DC)	5 VDC over MIPI CSI-2
Mass	40 g
Body dimensions (L \times W \times H in mm)	26 \times 29 \times 29
Regulations	2011/65/EU, including amendment 2015/863/EU (RoHS)

Quantum efficiency

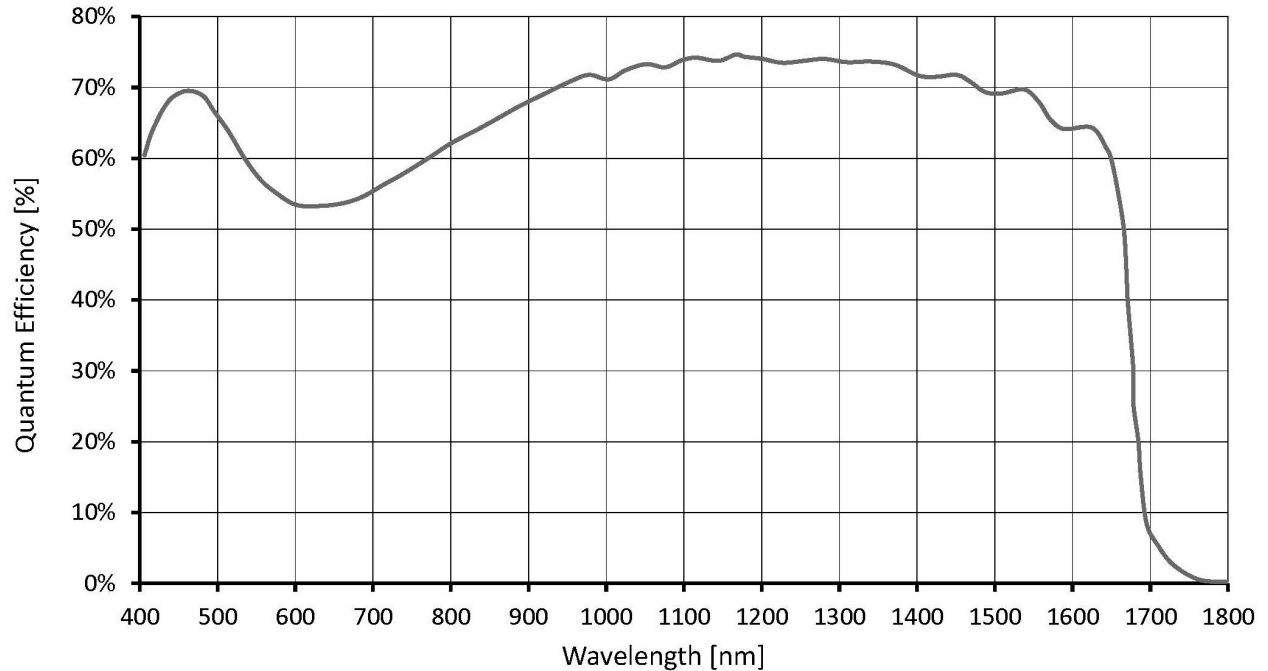

Features

Image control: Auto

- Auto exposure
- Auto gain

Image control: Other

- Black level
- DPC (defect pixel correction)
- Gamma
- Reverse X/Y
- ROI (region of interest)

Camera control

- Acquisition frame rate
- Firmware update in the field
- I/O and trigger control
- Temperature monitoring

Technical drawing

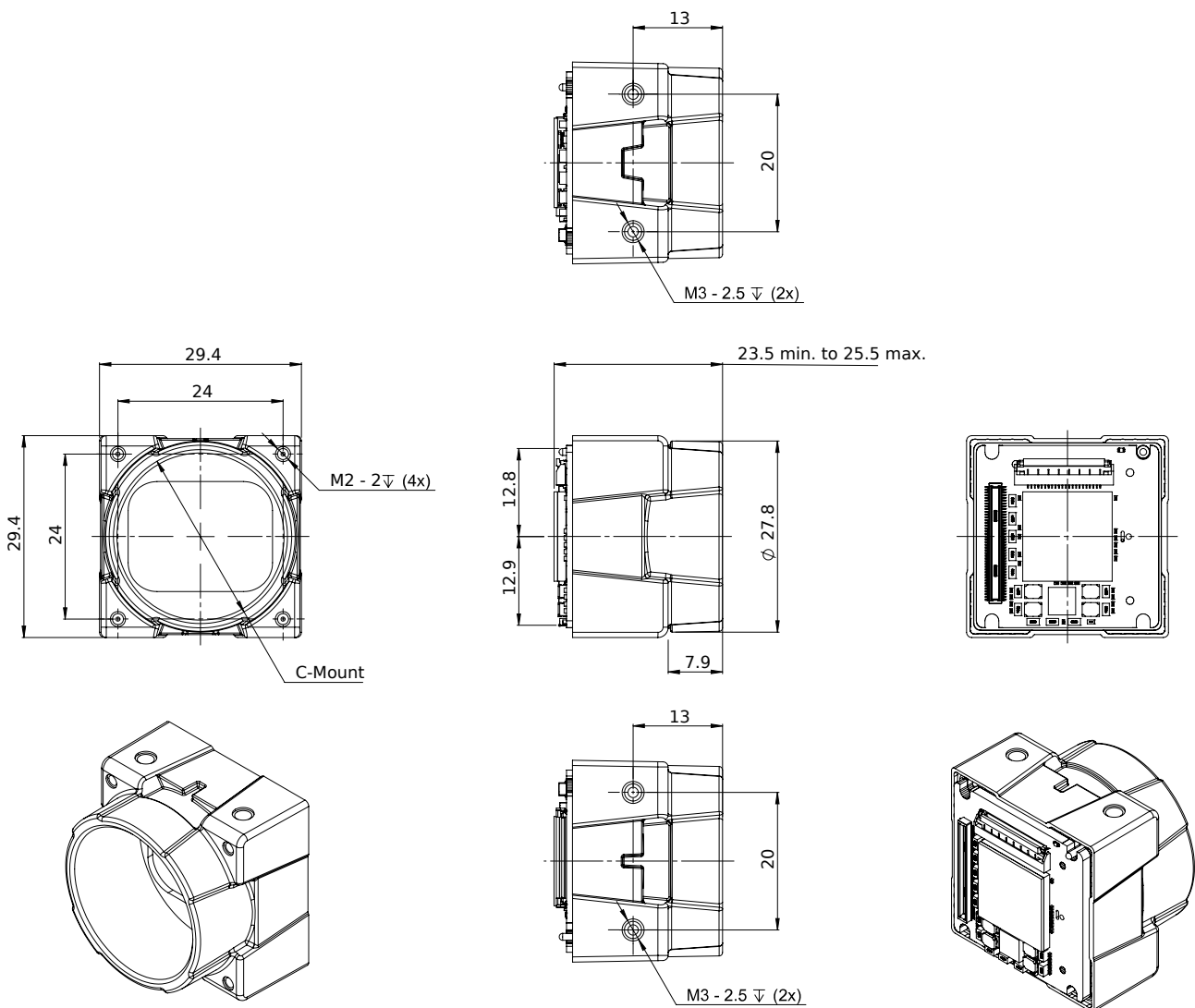

Applications

Alvium 1800 C-030 cameras are sensitive in the visible and the SWIR spectrum and are well-suited for many typical SWIR applications in various industry branches:

- Semiconductor industry: Solar cell and chip inspection
- Recycling industry: Plastic sorting
- Medical imaging, sciences: Hyper- and multi-spectral imaging
- Glass industry: Defect detection through hot glass
- Agriculture industry: Airborne remote sensing
- Printing industry: Seeing hidden features
- Surveillance: Vision enhancement (for example, seeing through fog or haze)
- Security: Counterfeit detection (such as for money, faked hair, or skin)