



Goldeye

G-034 TEC1

- Fast GigE Vision InGaAs SWIR camera
- VGA resolution
- Power over Ethernet
- Compact industrial design, no fan

Goldeye G-034 TEC1 - High-speed VGA InGaAs camera

The Goldeye G-034 TEC1 high-speed camera is the fastest VGA resolution short wave infrared camera (SWIR) with GigE Vision interface. Frame rates up to 303 fps at full resolution enable you to access versatile application fields and to speed up your processes.

Save time and money to integrate the camera into your system: A small form factor and multiple mounting options let the camera fit easily into compact system designs. In addition, its standardized GigE Vision interface including Power over Ethernet and comprehensive I/O control options simplify the connection to your software solution and the synchronization with other system components.

The integrated thermo-electric sensor cooling and several on-board image correction features contribute to the Goldeye's outstanding image quality.

Reveal more of the invisible with Goldeye SWIR cameras!

Benefits and features

- Compact industrial design
- Up to 303 fps at full resolution
- GigE Vision interface with Power over Ethernet
- Comprehensive I/O control options
- Automated on-board image correction
- Stabilized sensor cooling, no fan
- Extended operating temperature range

Hardware options

- Various lens mounts: Select between C-Mount, F-Mount, or M42-Mount

Specifications

Goldeye	G-034 TEC1
Interface	IEEE 802.3 1000BASE-T, IEEE 802.3af (PoE)
Resolution	636 (H) × 508 (V)
Spectral range	900 nm to 1700 nm
Sensor	InGaAs FPA 636 × 508
Sensor type	InGaAs
Sensor size	No standard size
Pixel size	15 μm × 15 μm
Lens mounts (available)	C-Mount, F-Mount, M42-Mount
Max. frame rate at full resolution	303 fps
ADC	14 Bit
Image buffer (RAM)	256 MByte
Imaging performance	
Cooling temperature	+5 °C, +20 °C (default and calibrated), +35 °C, +50 °C, or user-configurable
Dark current	49 ke ⁻ /s (at +20 °C FPA temperature)
Temporal dark noise	390 e ⁻ (Gain0), 53 e ⁻ (Gain1), 32 e ⁻ (Gain2)
Saturation capacity	1.2 Me ⁻ (Gain0), 84.8 ke ⁻ (Gain1), 25 ke ⁻ (Gain2)
Dynamic range	69 dB (Gain0), 64 dB (Gain1), 59 dB (Gain2)
Output	
Bit depth	8 - 14 Bit
Monochrome pixel formats	Mono8, Mono12, Mono12Packed, Mono14
General purpose inputs/outputs (GPIOs)	
TTL I/Os	LVTTL I/Os: 1 input, 1 output
Opto-isolated I/Os	1 Input, 2 Outputs
RS232	115 200 Baud, 8N1 (adjustable)
Operating conditions/dimensions	
Operating temperature	-20 °C to +55 °C (Case)
Power requirements (DC)	10.8 V DC to 30.0 V or via PoE
Power consumption	10.8 W (at 12 VDC), <12.95 W (PoE)
Mass	370 g (with C-Mount adapter)
Body dimensions (L × W × H in mm)	78 × 55 × 55
Regulations	CE: 2014/30/EU (EMC), 2011/65/EU, incl. amendment 2015/863/EU (RoHS); FCC Class B

Quantum efficiency

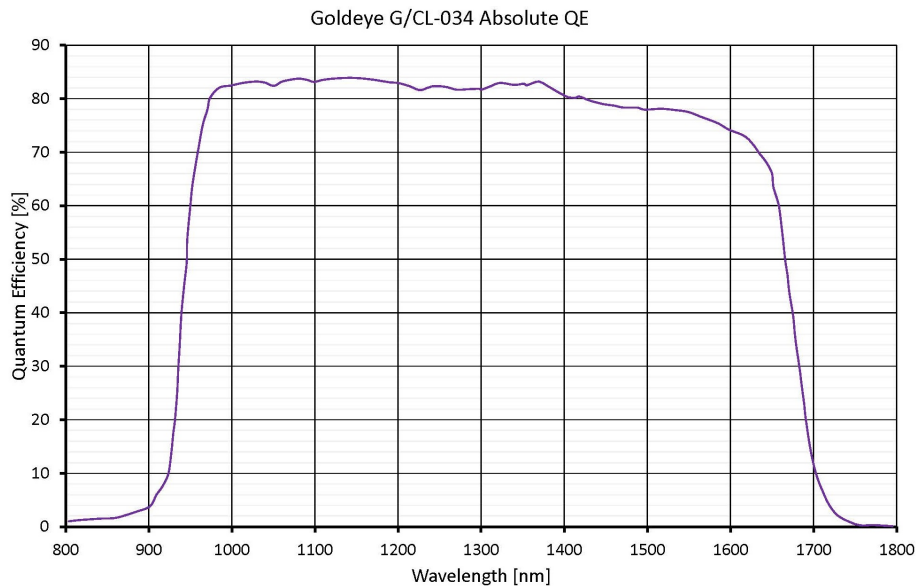

Features

IR-specific features (camera and sensor)

- Integrated correction data sets, compensation of sensor inhomogeneity and underlying structures (non-uniformity correction - NUC)
- Defect pixel correction
- Background correction
- Automated and manual sensor temperature management via TEC features
- Temperature status indicator
- Temperature specific events

General features

- Automatic exposure time control
- Gain (analog)
- I/O configuration and trigger control
- Stream hold (deferred image output)
- Storable user sets
- Firmware update in the field
- Region of interest (ROI) control, Look-up table (LUT) support, as well as various Auto-Features



Goldeye cameras are compatible with Allied Vision's Vimba SDK. Moreover, in combination with our AcquireControl software, extensive image analysis functions are available:

- Pseudo color LUT with several color profiles
- Auto contrast
- Auto brightness
- Analyze multiple regions (rectangular, circle) within the image
- Real-time statistics and histogram display

Technical drawing

Only for Badger T1

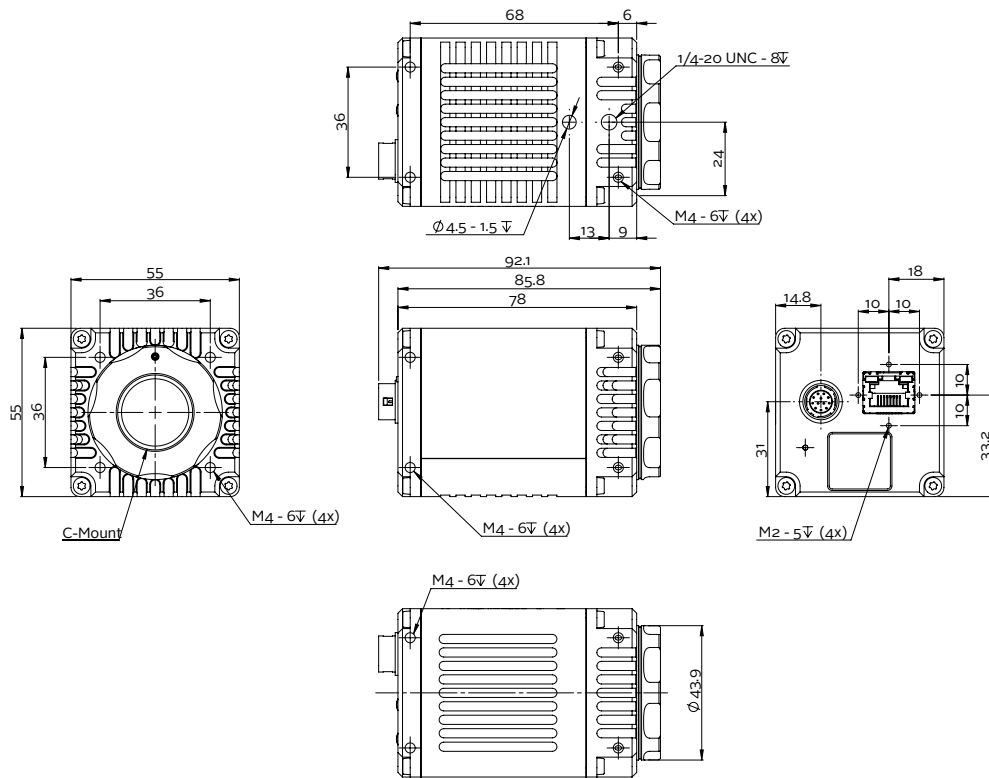



Applications

Goldeye cameras are very sensitive in the SWIR spectrum. They can be used in an extended operating temperature range. Thanks to temperature stabilization and integrated image correction, Goldeye cameras achieve an outstanding image quality with little noise and a high dynamic range. They are well-suited for many typical SWIR applications in various industry branches:

- Semiconductor industry: solar cell and chip inspection
- Recycling industry: plastics sorting
- Medical imaging, sciences: hyperspectral imaging, microscopy, OCT
- Metal and glass industry: thermal imaging of hot objects (250 °C to 800 °C)
- Agriculture industry: airborne remote sensing
- Printing industry: banknote inspection
- Electronics industry: laser beam profiling
- Surveillance and security: vision enhancement (for example, through fog or night vision)

White Paper

To learn more about typical application fields for SWIR cameras, download our White Paper:

[Seeing beyond the visible – short-wave infrared \(SWIR\) cameras offer new application fields in machine vision](#)