

Manta G-895



- Latest Sony CMOS sensor
- Power over Ethernet option
- Angled-head and board level variants
- Video-iris lens control

Simplify your setup of multi-camera applications

Modular machine vision camera with GigE Vision interface

Manta G-895 with Sony IMX267 runs 13.4 frames per second at 8.9 MP resolution.

Manta is Allied Vision's most versatile GigE Vision camera series. It provides the largest choice of image sensors and its advanced feature set simplifies the setup of multi-camera applications. With its modular hardware concept, Manta offers nearly endless configuration possibilities to adapt the camera to your application.

Easy software integration with Allied Vision's **Vimba Suite** and compatibility to the most popular **third party image-processing libraries**.

See the **Modular Concept** for lens mount, housing variants, optical filters, case design, and other modular options. See the **Customization and OEM Solutions** webpage for additional options.

Specifications

Manta G-895	
Interface	IEEE 802.3 1000BASE-T, IEEE 802.3af (PoE) optional
Resolution	4112 (H) × 2176 (V)
Sensor	Sony IMX267
Sensor type	CMOS
Shutter mode	Global shutter
Sensor size	Type 1
Pixel size	3.45 μm × 3.45 μm

Manta G-895	
Lens mounts (available)	C-Mount, CS-Mount
Max. frame rate at full resolution	13.4 fps
ADC	12 Bit
Image buffer (RAM)	128 MByte
Imaging performance	
Imaging performance data is based on the evaluation methods in the EMVA 1288 Release 3.1 standard for characterization of image sensors and cameras. Measurements are typical values for monochrome models measured at full resolution without optical filter. Contact Sales or AE for more information.	
Quantum efficiency at 529 nm	63 %
Temporal dark noise	2.1 e ⁻
Saturation capacity	10500 e ⁻
Dynamic range	71.8 dB
Absolute sensitivity threshold	2.7 e ⁻
Output	
Bit depth	8/12 Bit
Monochrome pixel formats	Mono8, Mono12Packed, Mono12
YUV color pixel formats	YUV411Packed, YUV422Packed, YUV444Packed
RGB color pixel formats	RGB8Packed, BGR8Packed
Raw pixel formats	BayerRG8, BayerRG12, BayerRG12Packed
General purpose inputs/outputs (GPIOs)	
Opto-isolated I/Os	2 inputs, 2 outputs
RS232	1
Operating conditions/dimensions	
Operating temperature	+5 °C to +45 °C ambient (without condensation)
Power requirements (DC)	8 to 30 VDC AUX or IEEE 802.3af PoE
Power consumption	External power: 3.0 W at 12 VDC Power over Ethernet: 3.3 W
Mass	190 g; 200 g (PoE)
Body dimensions (L × W × H in mm)	86.3 × 44 × 29 (including connectors)
Regulations	CE: 2014/30/EU (EMC), 2011/65/EU, including amendment 2015/863/EU (RoHS); FCC Class B; CAN ICES-3 (B)

Quantum efficiency

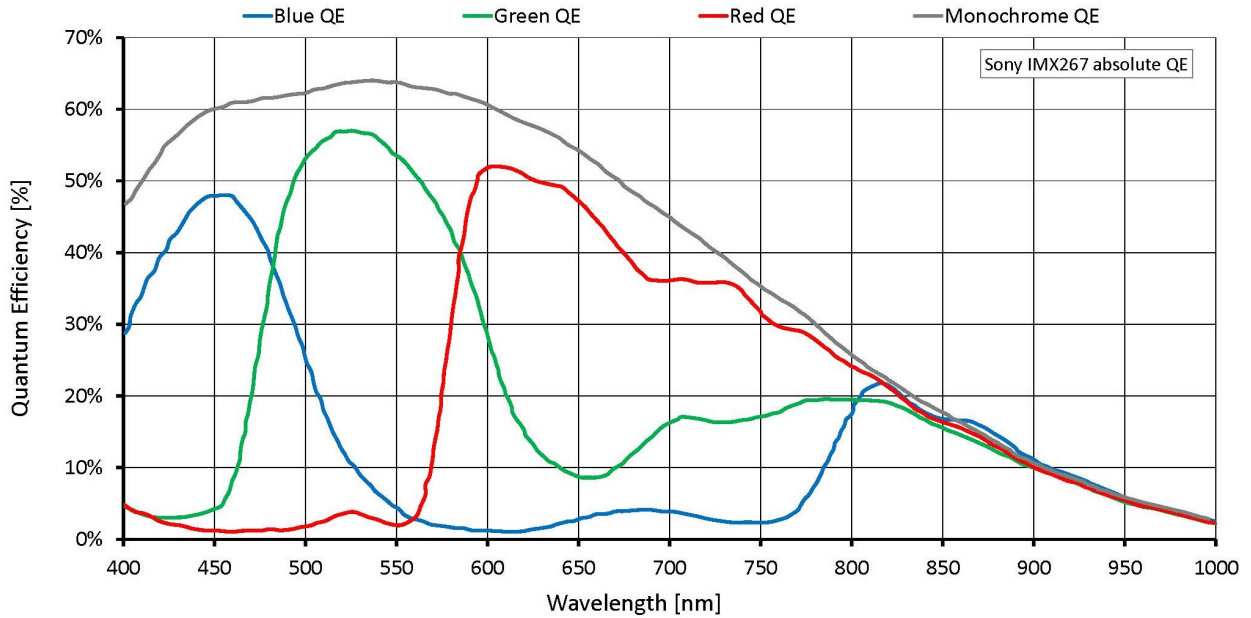

Features

Image optimization features:

- Auto gain (manual gain control: 0 to 40 dB; 0.1 dB increments)
- Auto exposure (exposure time control varies by pixel format)
- Auto white balance (G-895C only)
- Binning
- Black level (offset)
- Color correction, hue, saturation (G-895C only)
- Decimation X/Y
- Gamma correction
- Three look-up tables
- Region of interest, separate region for auto features
- Reverse X/Y

Camera control features:

- Auto-iris (video type)
- Event channel
- Image chunk data
- IEEE 1588 Precision Time Protocol
- Storable user sets
- StreamBytesPerSecond (easy bandwidth control)
- Stream hold
- Sync out modes: Trigger ready, input, exposing, readout, imaging, strobe, GPO
- Temperature monitoring (main board)
- Trigger over Ethernet Action Commands

Technical drawing

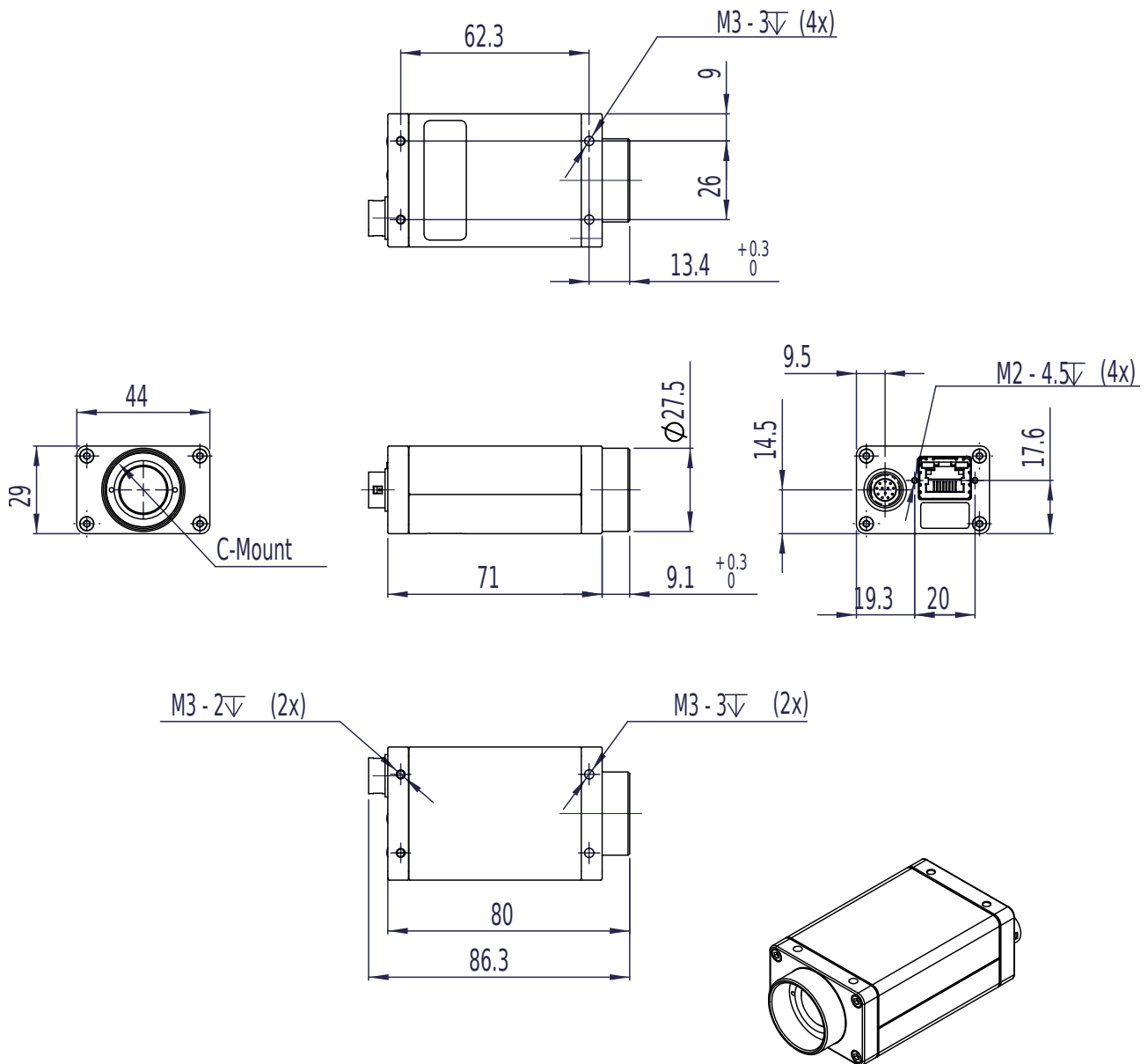

Applications

Manta G-895 is ideal for a wide range of applications including:

- Machine Vision
- Broadcast analysis requiring full HD such as sports analytics



- Industrial inspection
- Security and surveillance
- Intelligent traffic solutions (ITS), traffic (traffic monitoring, speed enforcement, toll collection)
- Low light or high sensitivity conditions
- Outdoor applications with dynamic lighting situations