

CoaxPress®

EoSens® 4CXP

User Guide

Content

1	Before you start	4
1.1	About this manual	4
1.1.1	Tips, remarks, and notes	4
1.1.2	Registered trademarks	4
1.1.3	Conformity and use	4
1.1.4	Supplements	5
1.2	Warranty and non-warranty clause	6
1.3	Support	6
2	Introduction	7
2.1	Intended use	7
2.2	Scope of delivery	7
2.3	Optional accessories	7
2.4	System requirements	8
3	The camera	9
3.1	Camera description	9
3.2	Operating temperature	10
3.3	Additional cooling	10
3.4	Interfaces of the camera	11
3.5	Status LED	12
4	First steps	13
4.1	Connecting a frame grabber	13
4.2	Connecting an external power supply or I/O signals	14
4.3	Connecting camera and image processing system	16
4.4	The power-up profile	17
4.5	Cleaning sensor and lens	17
4.6	Updating the camera firmware	17
5	Technical data	19
5.1	Camera specifications	19
5.2	Sensor specifications	20
5.3	Resolution and frame rates	20
5.4	Camera dimensions	20

5.5	Spectral response	22
5.5.1	Monochrome and color	22
6	Appendix	24
	Declaration of Conformity	25

1 Before you start

1.1 About this manual

This manual contains helpful information to install and operate the described camera. It has been produced with care. Nevertheless, information might be erroneous or incomplete. Mikrotron GmbH cannot be held responsible for any problems resulting from incomplete or erroneous information.

In case you detect errors or need further information, please inform us via mail:

service@mikrotron.de or

Call +49- 89-7263-4200

We highly recommend to read this manual carefully.

NOTICE This manual is subject to change without notice.

It is intended for staff with technical qualifications who have been specially trained and have the appropriate knowledge in the field of automation technology, electrical and optical devices.

INFO *Keep this manual for future use.*

1.1.1 Tips, remarks, and notes

This manual contains tips and notes that help to avoid data loss or camera damage. They are emphasized as follows:

INFO *Provides information that may help to improve camera handling or avoid data loss.*

NOTICE *Provides information to avoid damage to the system.*

1.1.2 Registered trademarks

In this manual the following registered trademarks may be used:

- MotionBLITZ®
- ImageBLITZ®
- EoSens®
- GenlCam®
- Microsoft® and Windows®
- Intel®

Throughout the manual, these trademarks are not specifically marked as registered trademarks. This in no way implies that these trademarks can be used in another context without the trademark sign.

1.1.3 Conformity and use

This equipment has been tested and found to comply with the limits for a Class A digital device, pursuant to Part 15 of the FCC Rules. These requirements are designed to provide reasonable protection against harmful interference when the equipment is operated in a commercial environment.

This equipment generates, uses, and can radiate radio frequency energy and, if not installed and used in accordance with the instructions given in this guide, may cause harmful interference to radio communications. Operation of this equipment in a residential area is likely to cause harmful interference in which case the user will have to correct the interference at its own expense.

NOTICE

You are herewith cautioned that any changes or modifications not expressly approved in this description could void your authority to operate this equipment.

製造説明：

此设备的生产与测试依照FCC条例第15条条例，符合A类电子设备标准。产品提供在商用使用环境中的合理保护，以防止使用过程中可能涉及到的损害。

此设备会产生、使用并可发射出无线电波，如果未按照本手册中所述安装和使用，可能会对无线通信设备产生干扰。如本设备在居民区操作出现干扰等情况，用户需要自费处理。

备注：请注意，如未按照此使用说明操作而自行更改设备，那么您将无权使用本设备。

規制適合宣言とご使用について(米国FCC)

この機器は、FCC規則のパート15に定められたクラスAデジタル装置に関する規制要件に基づいて所定の試験が実施され、その適合が認証されています。これらの規制要件は、商業環境において機器を使用する際、有害な干渉に対する妥当な保護を提供するために設けられています。この機器は、無線周波数エネルギーを生成かつ利用するとともに、放射することもあります。このリファレンスガイドの指示に従って設置および使用が行われない場合は、無線通信に有害な干渉を引き起こす恐れがあります。この機器を住宅地で利用すると有害な干渉を起こすこともあり、その場合、使用者は自己負担において適切な対策を講じる必要があります。

注意事項：このリファレンスガイドに明示的に承認していない変更や修正を行った場合には、本製品を使用する権利が無効となることがあります。

1.1.4 Supplements

For customers in Canada

This apparatus complies with the Class A limits for radio noise emissions set out in Radio Interference Regulations.

Pour les utilisateurs au Canada

Cet appareil est conforme aux normes Classe A pour bruits radioélectriques, spécifiées dans le Règlement sur le brouillage radioélectrique.

Life support applications

The products described in this manual are not designed for use in life support appliances or devices and systems where malfunction of these products can reasonably be expected to result in personal injury.

NOTICE Mikrotron customers using or selling these products for use in such applications do so at their own risk and agree to fully indemnify Mikrotron for any damages resulting from such improper use or sale.

1.2 Warranty and non-warranty clause

Warranty is described in §8 of our General Terms and Conditions which can be downloaded on the Mikrotron web page (www.mikrotron.de/en/terms.html).

In addition, take the following non-warranty clauses into account.

NOTICE The camera does not contain serviceable parts. Do not open the body of the camera. If the camera has been opened, the warranty will be void.

NOTICE The camera has to be used with a supply voltage according to the camera's specification. Connecting a lower or higher supply voltage, AC voltage, reversal polarity or using wrong pins of the power connector may damage the camera. Doing so will void warranty.

Our warranty does not protect against accidental damage, loss, or acts of nature.

INFO *Mikrotron cannot be held responsible for the loss of data. We recommend a backup plan.*

1.3 Support

1. In case of support or a warranty claim, make a note of the camera type and its serial number (S/N). You find all necessary information on the identification plate of the camera.
2. Contact us in one of the following ways:
 - Contact us via email: support@mikrotron.de. Our support team will guide you through the process.
 - Or visit our support website www.mikrotron.de/en/services/support.html and fill out the form. You will receive an automatic reply from our ticket system.

2 Introduction

2.1 Intended use

The camera EoSens® 4CXP belongs to the product class of so-called high-speed machine vision (MV) cameras that are integrated into test or measurement systems.

High-speed MV cameras are designed to capture images with high frame rate for various purposes in an industrial or scientific environment to deliver image data for further analysis. The images are transmitted to a frame grabber on a connected computer where they can be evaluated with the help of a software.

Other uses

Any other use is regarded as unintended use and leads to the loss of guarantee and liabilities. Contact the manufacturer for other uses.

These products are designed for industrial applications only. **The cameras are not designed for life support systems where malfunction of the products might result in any risk of personal harm or injury.**

2.2 Scope of delivery

The following components are part of delivery. Before installing the camera, check if the delivery is complete:

- Camera as ordered
- F-mount or C-mount lens adapter - as ordered
- USB storage device with
 - VCAM2 software
 - GenICam XML file
 - Product documentation

NOTICE Check if the delivery is complete before installing the camera.

INFO *The firmware can be updated remotely via a special updating software. For firmware updates, inform Mikrotron via email: info@mikrotron.de.*

2.3 Optional accessories

Lenses

Only lenses for industrial purpose are suitable. To find lenses or other accessories, visit www.mikrotron.de/en.

Cables

- The four bundle cable KKRDDINDINxx/6Gx4 with DIN 1.0/2.3 connector at both ends (4x) is available in lengths of 5 m, 10 m, 15 m, or 20 m. It is used to connect the frame grabber and camera when both are equipped with DIN 1.0/2.3 connectors.
- The cable KKRDDINBNCxx/6Gx4 with DIN 1.0/2.3 at one end and 4 BNC connectors at the other is available lengths of 5 m, 10 m, 15, m 20 m, or 25 m. It is used to connect a frame grabber with BNC sockets with the camera.

INFO

The triangle on the connector indicates connection number 1.

Power supply

If you do not use power over CXP (PoCXP), you need an external power supply unit, e.g.:

- NTCAM132X (12 V/2.5 A) with 12 pin Hirose connector (HR10A-10P-12S(73)) and 5 m cable

2.4 System requirements

The PC or image processing system that is connected with the camera must be equipped with:

- An image processing system, i.e. PC and operating system according to the requirements of the frame grabber
- A fully installed frame grabber with device driver and software
- CoaXPress cable with DIN 1.0/2.3 connector
- Optional an external power supply (NTCAM132x or NTCAM13xx)

INFO

All cables, connectors and the frame grabber must be CoaXPress V1.1 compliant.

3 The camera

3.1 Camera description

All cameras of the EoSens CXP family are CoaXPress compliant. The high-speed CMOS cameras come with a 4.0 Megapixel sensor of 2336 x 1728 (H x V). They are widely configurable and scalable to fit your needs and are available in monochrome and color (Bayer filter).

The CoaXPress high speed interface technology allows transfer rates of up to 6.25 Gb/s. The camera supports CoaXPress Link Speeds from 3.125 Gb/s to 6.25 Gb/s.

In addition the camera offers a very high frame rate of over 563 fps at full resolution. By defining a Region of Interest (ROI) the frame rate can be increased to several thousand frames per second. An important feature of CXP cameras is the high photo sensitivity for low-light conditions.

The camera electronic is enclosed in a compact and solid full metal housing robust enough to comply with the requirements in heavy industrial surroundings. Shielded coaxial cables as recommended by the CoaXPress standard will support this.

CXP cameras can be equipped with standard C-mount or F-mount lenses made for industrial purpose.

The color and monochrome cameras EoSens® 4CXP are supplied with the following features:

- 3x3 image smoothing filter
- Analog gain
- Decimation mode (subsampling)
- Firmware update in the field
- FPN correction
- Gamma correction (monochrome only)
- LUT
- Pixel reset mode
- PRNU correction (Photo Response Non-Uniformity correction)
- Sequencer mode - if ordered
- Skipping
- Trigger debouncer
- 3 user profiles

Bayer filter

The sensor of the EoSens color cameras is supplied with a Bayer color filter. In order to get the color information, the imaging software has to decode the information of each pixel into red, green, and blue (RGB) by using the values of its neighboring pixels. Each red, green and blue filter element covers exactly one pixel on the sensor. A matrix of 2 x 2 filter elements builds a filter element matrix. A Bayer pattern image therefore must have an even number of pixels and an even number of lines. The ordering of the RGB pixels for each sensor is provided in the section on technical data.

UV / IR cut filter

In addition, color cameras are equipped with an UV / IR cut filter. Light with wavelengths between 370 nm and 670 nm will be transmitted. As CMOS sensors are susceptible to UV and IR rays outside the visible spectrum, UV / IR filter avoid blurred images and therefore improve color images.

3.2 Operating temperature

Despite of its high performance, the fanless 4CXP camera is compact and works silently. If the camera is mounted on mechanical parts, the heat generated during operation will be dissipated by the cooling fins at the rear of the camera and the mechanical parts.

NOTICE The camera body temperature must not exceed the values specified in the technical data (see "Technical data" on page 19).

In case of overheating, the camera will automatically be switched off and the communication between camera and PC will be interrupted.

INFO *Durability of the camera will be reduced when being operated in an environment that is constantly exceeding the maximum permissible operating temperature. In this case, take additional cooling measures as described below.*

NOTICE The camera is not intended for use on an isolated mounting plate or in a closed housing because the temperature of the camera will rise continuously.

3.3 Additional cooling

INFO *If the camera is e.g. mounted on a sturdy aluminum structure, not only cooling is ensured but also a stable optical path. In addition, vibrations will be minimized within the entire system.*

If the ambient temperature is constantly exceeding 40 °C, additional cooling is recommended. This can be achieved by

- Air- or water-cooling system
- Air-conditioned housings

3.4 Interfaces of the camera

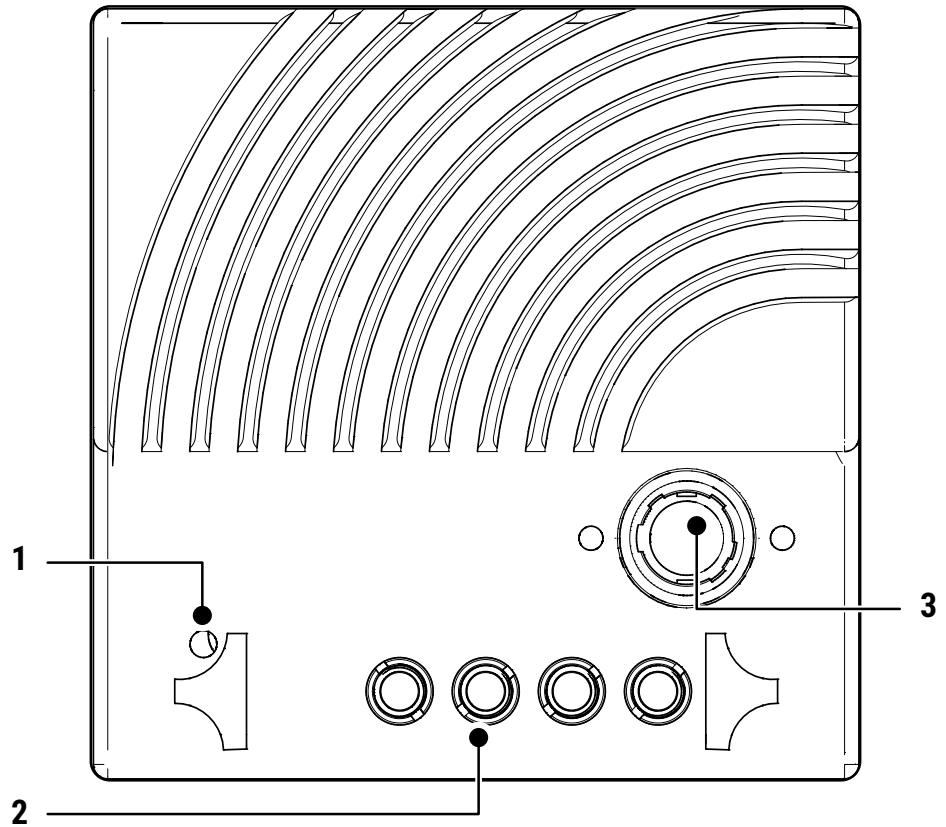

Fig.: 3-1: Interfaces of the camera EoSens® 4CXP

1	Status LED to verify the operating status of the camera
2	CoaXPress DIN1.0 / 2.3 connector used to connect the camera with a CoaXPress compliant frame grabber.
3	12 pin Hirose power connector used when an external power supply (12 ... 24 V) has to be connected, an external trigger is connected and / or an output signal is used.

3.5 Status LED

The multi-color status LED indicates camera and connection states.

LED State	Indication
OFF	No power
Solid orange	System is booting
Slow pulse red	Powered, but nothing connected (not applicable if PoC is used)
Fast flash alternate green/orange	Connection detection in progress, PoC active
Fast flash orange	Connection detection in progress, PoC not in use
Slow flash alternate red/green	Device incompatible, PoC active
Slow flash alternate red/orange	Device incompatible, PoC not in use
Solid green	Device connected but no data being transferred
Slow pulse orange	Device connected, waiting for event (e.g. trigger)
Fast flash green	Device connected, data being transferred
Slow flash alternate green/orange	Connection test packets being sent
Red - 500 ms pulse	Error during data transfer
Slow flash alternate red/green/orange	Compliance test mode enabled
Fast flash red	System error

4 First steps

4.1 Connecting a frame grabber

The CoaXPress standard describes seven connections for data transmission between camera and frame grabber.

The transmission speed of the camera can either be set to 1.25, 2.5, 3.125, 5, or 6.25 Gb/s. The possible cable length depends on the cable type used, its quality, and the selected transmission speed. The following table provides examples. These values will only be reached if the signal quality meets the requirements of the CXP1.1 specification.

INFO

The maximal cable length depends also on the quality of the cables. We recommend CXP cables from Mikrotron.

All lines have to be of the same length.

CXP-Type	Transmission speed [Gb/s]	Max. cable length RG59 style [m]
CXP-1	1.25	up to 130
CXP-2	2,5	up to 110
CXP-3	3.125	up to 100
CXP-5	5	up to 60
CXP-6	6.25	up to 40
4*CXP-6	4*6.25 (= 25)	up to 40

DIN Connector

To connect the camera with a frame grabber you can use any CoaXPress compatible cable with DIN connector. Mikrotron offers cables with the following connectors.

- DIN ↔ DIN
(cable KKRDDINDINxx/6Gx4)
- DIN ↔ BNC
(cable KKRDDINBNCxx/6Gx4)

NOTICE

Carefully connect and release the socket with the DIN1.1/2.3 connector. Connect them precisely to avoid deformation of the connectors or other damages!

If connecting a frame grabber via DIN ↔ BNC, keep the order from left to right when connecting one, two, or four BNC connectors.

INFO

Pin 1 always has to be connected.

The master connector (1) is marked by a triangle. Connect it with channel one of the frame grabber (refer to the frame grabber documentation).

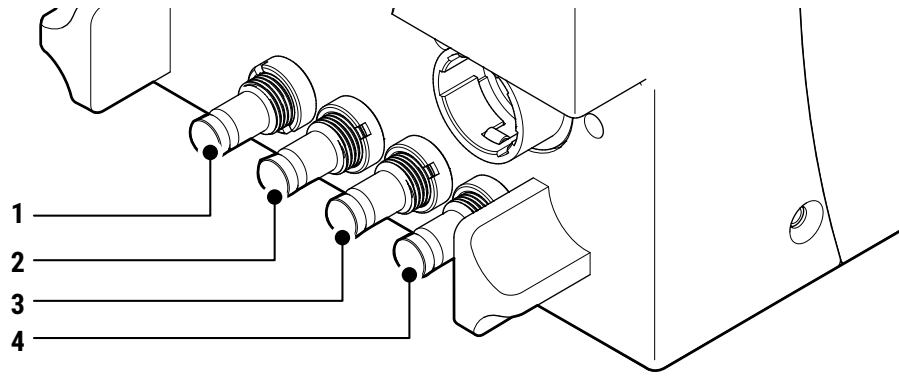

INFO

All connections are hot-pluggable.

The assignment of the DIN cables KKRDDINDINxx/6Gx4 and KKRDDINBNCxx/6Gx4 connector pins is as follows:

DIN connector pin	Frame grabber	Cable color
1 (triangle)	TX channel 0	Red
2	TX channel 1	Green
3	TX channel 2	Blue
4	TX channel 3	Yellow

4.2 Connecting an external power supply or I/O signals

If you prefer an external 12 - 24V DC power supply (min. 18 W), connect it with the 12-pin Hirose connector at the rear of the camera.

NOTICE

The power connector of the camera has to be connected with a DC power supply providing 12 to 24 V DC. Connecting a lower or higher supply voltage, an AC voltage, reversal polarity or using wrong pins of the power connector may damage the camera and will void warranty!

Mikrotron offers the power supply unit NTCAM132xx with cables of 5 or 10 meters.

INFO

If you assemble your own cable, pay attention to the pinning described below.

12-pin connector and I/O signals

1. Connect the external power supply with the 12-pin connector of the camera.

NOTICE

The DC power supply must deliver 12-24 V DC (18.4 W). It must be equipped with a HR-10A-10P-12S plug.

The 12 pin connector provides two inputs for an external trigger and two output signals. The output signal can be controlled.

Pin	Signal	Pin	Signal
1 + 12	GND	6	IN0
2 + 11	VCC (12 - 24 V)	7	IO _{GND}
3	IO _{GND}	8	OUT1
4	OUT0	9	IO _{GND}
5	IO _{GND}	10	IN1

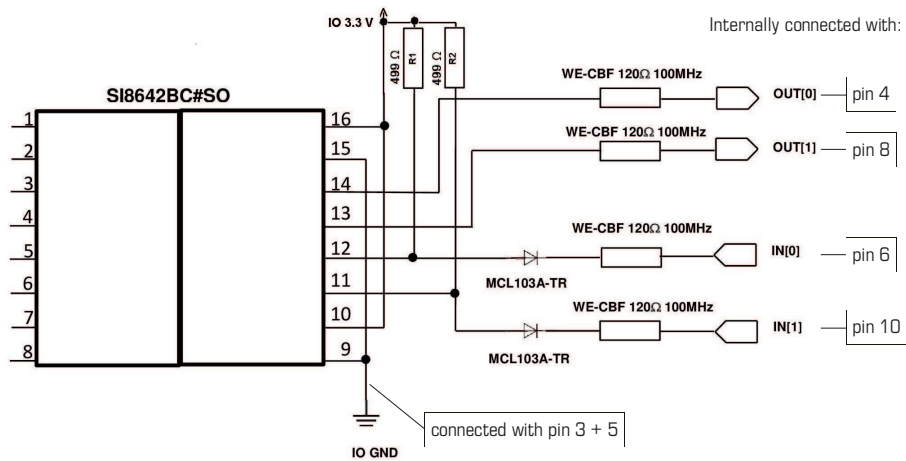
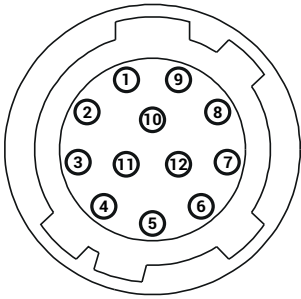

Fig.: 4-1: Connecting input and output signals with the internal circuit

All inputs accept 3.3 V LVTTTL signals. They are also 5 V TTL compatible.

All inputs can also accept signals with 12 V and 24 V.

NOTICE An open (not connected) input will be interpreted as high level from the camera. For low level an input voltage of 0 - 0.3V must be connected.

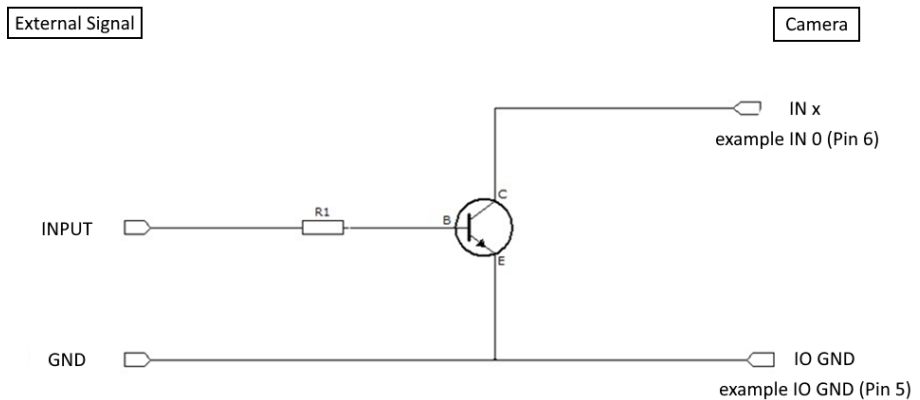

Fig.: 4-2: IO signals

If the available external signal cannot deliver a low level voltage <0.3 V or the input signal is >24 V, the following transistor circuit can be used. A suitable transistor is for example BC547, or 2N2222.

NOTICE This circuit will invert the signal. (A high level at the input will be seen as low level at the camera.)

Examples for R1

Input voltage	Resistor
3.3 V	2.7 kOhm
5 V	4.7 kOhm
12 V	12 kOhm
24 V	22 kOhm

4.3 Connecting camera and image processing system

To make use of the full performance, all cables, connectors and the frame grabber must be CoaXPress V1.1 compliant.

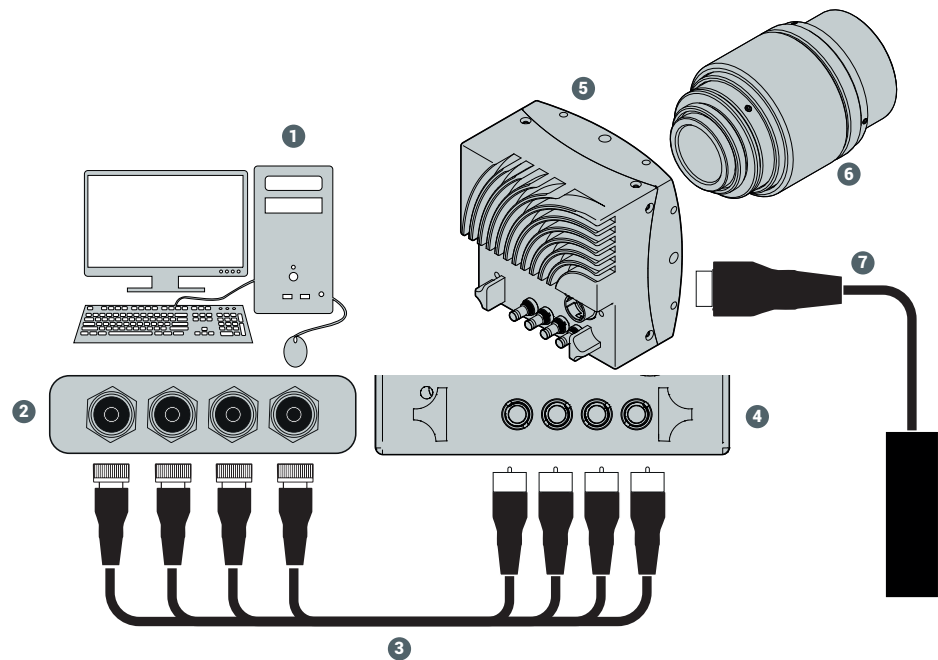

Fig.: 4-3: Connecting camera and image processing system

1. Install the frame grabber software on the image processing system (see the documentation of the frame grabber board).
2. Switch off the image processing system (1).
3. Unscrew the dust protection cover of the camera.
4. Mount the lens (6).
5. Connect the cable (3) with the camera connectors (4).
6. Connect the other end of the cable with the frame grabber board (2).
7. Connect the power supply via the 12-pin connector with the camera (5), if required.

INFO If connecting an external trigger, take the pinning into account.

8. If an external power supply (7) is used, connect the power supply with the main supply.
9. Switch on the image processing system (1).
10. Check the status LED of the camera to verify that the camera is ready for use.

4.4 The power-up profile

If the camera is powered-up, the power-up profile permanently stored in the non-volatile memory of the camera will be loaded. This profile consists of a number of camera settings such as sensor resolution and frame rate. It is used to set the camera into a defined operation mode.

INFO

The camera has NOT to be configured by the host to start operation. The power-up profile will deliver all necessary values.

Serial number and firmware version are provided in the non-volatile memory of the camera. Use the GenICam feature "DeviceSerialNumber" to read the serial number and the firmware revision.

INFO

Read the chapter on Bootstrap Registers in the Reference Guide for more information. For the serial number, see the identification plate at the side of the camera.

4.5 Cleaning sensor and lens

Unplug the camera before you clean any parts!

Never open the housing when cleaning the window of the sensor. If the camera has been opened, the warranty will be void.

1. If there are coarse particles on the lens or the window of the sensor, use a vacuum cleaner to remove them before cleaning to prevent scratches.
2. Clean the window of the sensor and the lens with a dry and soft lens-cleaning tissue.

NOTICE

Do not use tools that may harm the sensor or lens.

4.6 Updating the camera firmware

This section describes how to carry out a firmware update for a camera from Mikrotron GmbH using the software "CXPUdater".

Prerequisites

INFO

The updater software requires the Microsoft Redistributables for Visual Studio 2015-2019 (vc_redist_x64.exe) that can be downloaded from Microsoft for free.

Procedure

The updater process requires frame grabber specific components. The program assumes that there is a "Data" folder containing the following files:

- FlashData.ibf
- fpga_app_firmware.ibf

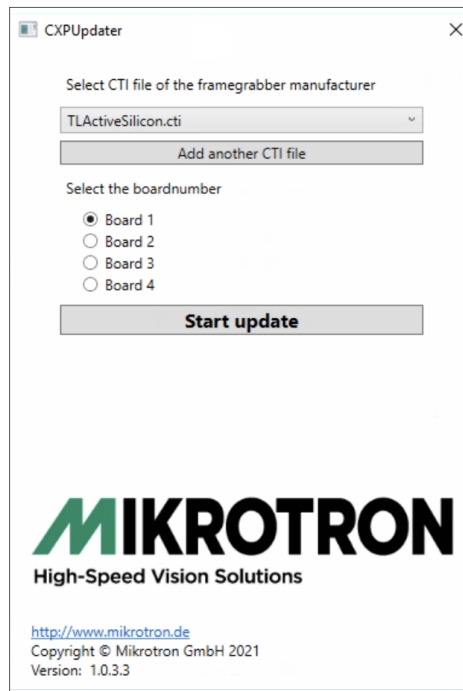

1. Open the tool “CXP Updater.exe” in the folder “Firmware”.
2. Select the CTI file that corresponds to the frame grabber board. If unsure, consult the Device Manager.
3. To add a CTI file that is not in the list, select **Add another CTI file** and navigate to the file.
4. Select the board for updating.
5. Start the update process. The progress bar displays the current update status.

NOTICE Do not switch off the camera during the update process.

6. When the update is finished, restart the camera.

5 Technical data

5.1 Camera specifications

Frame rate (8 bit)	max. 225000
Pixel depth	8 / 10 bit
Shutter speed	1 μ s – 1 s
Shutter time (steps)	1 μ s
Max. Jitter	\pm 4 ns
Max. Trigger frequency	300 kHz
Quantum efficiency	>40% @ 550 nm
Interfaces	<ul style="list-style-type: none">• CoaXPress 1.x @ 1,25 Gb/s• CoaXPress 1.x @ 2,5 Gb/s• CoaXPress 1.x @ 3,125 Gb/s• CoaXPress 1.x @ 5 Gb/s• CoaXPress 1.x @ 6,25 Gb/s• PoCXP
Adapter	C- / F-mount
Dimensions (W x H x L)	80 x 80 x 53,4 mm (without lens adapter) 80 x 80 x 57 mm (C-mount) 80 x 80 x 81 mm (F-mount)
Weight	0,45 kg
Cooling	Fanless
Power supply	12 - 24 V DC @ 10 W (Power adapter supplied)
Operating temperature (camera body)	+5 °C ... +50 °C
Shock resistance	70 g
Vibration resistance	7 grms
Compliance	GenICam CoaXPress 1.1

5.2 Sensor specifications

Sensor type	CMOS; monochrome or RGB (Bayer filter)
Image sensor size	16.35 x 12.1 mm
Resolution	2336 x 1728 pixel
Pixel depth	8 bit / 10 bit
Pixel size	7 x 7 μm
Active area	16,35 x 12,10 mm
ROI min.	128 x 2 px
Fill factor	50 %
Light sensitivity	11 V/lux-s
Dynamic range up to	60 dB
Full well charge	22000 e ⁻
Bayer filter pattern	BayerGR8 / BayerGR10 Because the pattern must always start at the same field with a color camera only even height and even offset-y is possible. The camera will automatically round down if odd values are entered. Also bear in mind when using the invert readout function the pattern must be inverted too.

5.3 Resolution and frame rates

Resolution	Frame rate (8 bit)
2336 x 1728 px	563 fps
1920 x 1080 px	900 fps
1280 x 1024 px	949 fps
1024 x 768 px	1264 fps
800 x 600 px	1617 fps
640 x 480 px	2020 fps
512 x 512 px	1894 fps
320 x 240 px	4024 fps
128 x 128 px	7492 fps
128 x 2 px	225000 fps

INFO

Use our camera compare tool to calculate the frame rate for a certain ROI size.
www.mikrotron.de/cameracompare/

5.4 Camera dimensions

All dimensions in Millimeters.

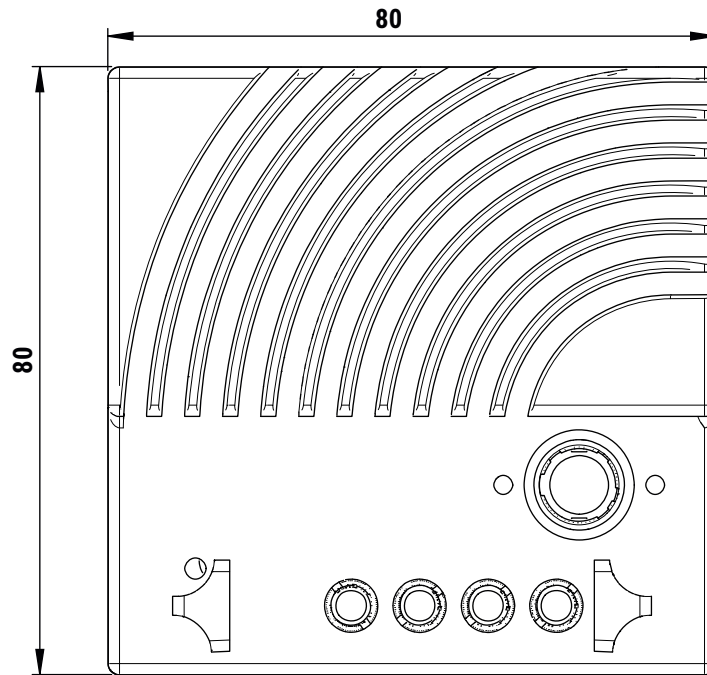

Fig.: 5-1: Rear view

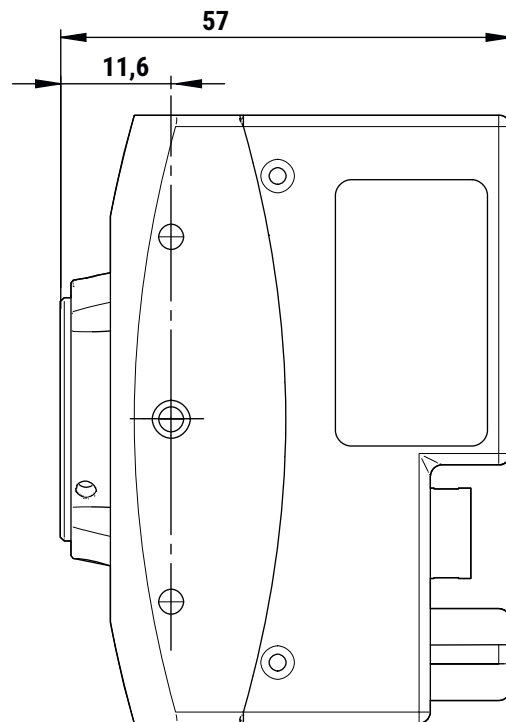

Fig.: 5-2: Side view with C-mount adapter

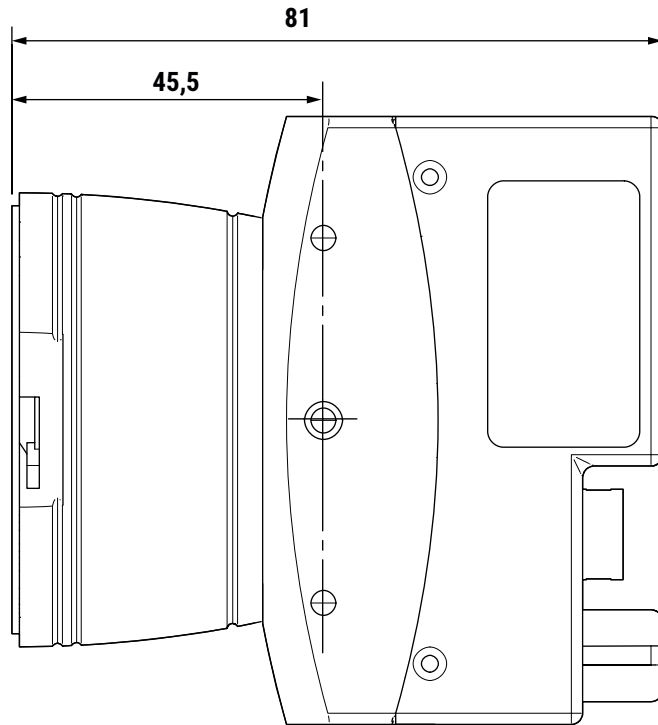

Fig.: 5-3: Side view with F-mount adapter

5.5 Spectral response

5.5.1 Monochrome and color

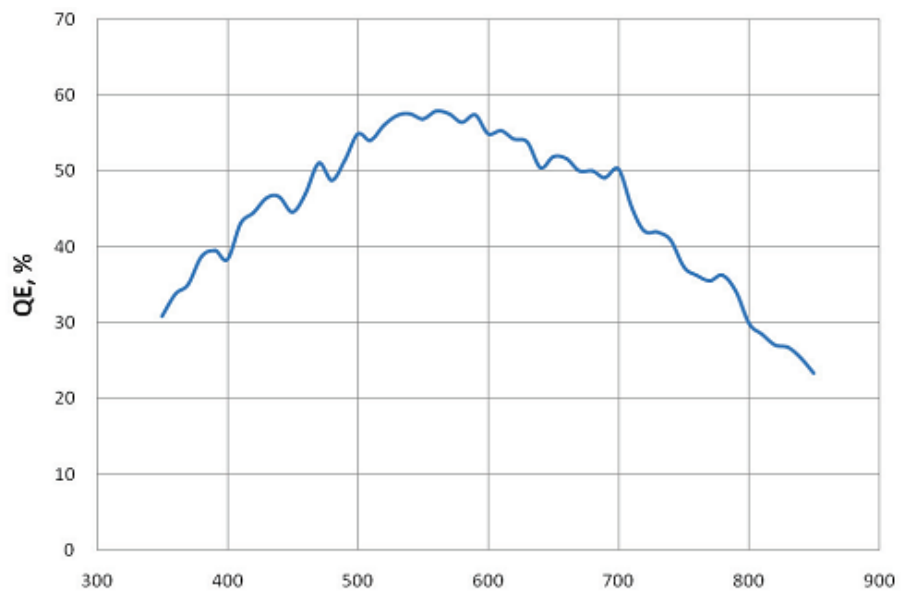

Fig.: 5-4: Quantum Efficiency Monochrome

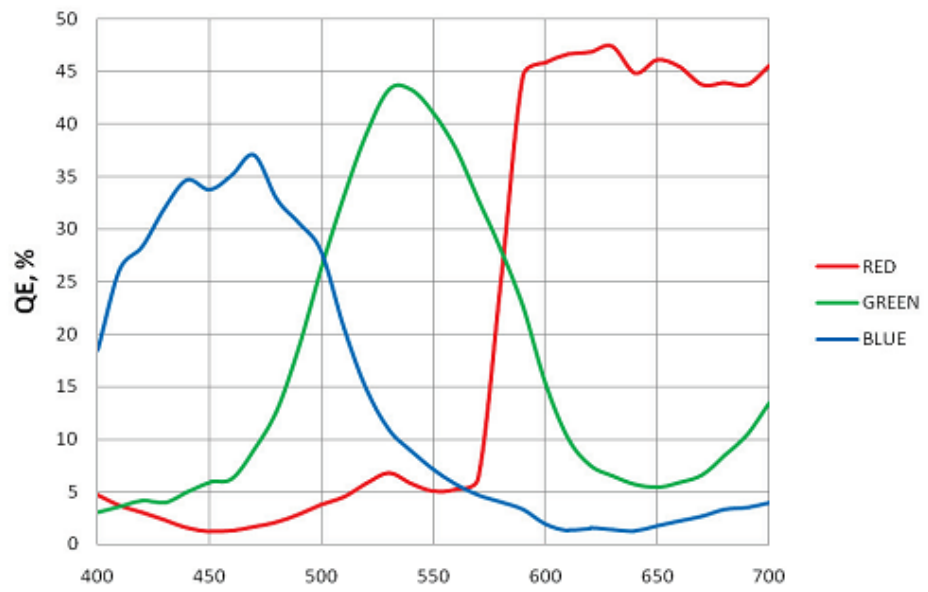

Fig.: 5-5: Quantum Efficiency Color

6 Appendix

The following page contains the Declaration(s) of Conformity.

EU Declaration of Conformity EU-Konformitätserklärung

Mikrotron GmbH
Landshuter Str.20-22
D-85716 Unterschleissheim
www.mikrotron.de

Phone: +49 (0)89 72634200
Fax: +49 (0)89 726342-99
Mail to: info@mikrotron.de

**We herewith declare under our sole responsibility that the products mentioned below:
Hiermit erklären wir in alleiniger Verantwortung, dass die folgenden Produkte:**

Product type: 4CXP Camera
Produkt: 4CXP Kamera

Models: CAMMC408x, and all variants
Modelle: CAMMC408x und alle Varianten

are in conformity with the following EU directives: / den folgenden EU-Richtlinien entsprechen:

Title / Titel	EU Directive / -Richtlinie
RoHS Directive on the Restriction of the Use of Certain Hazardous Substances in Electrical and Electronic Equipment RoHS-Richtlinie zur Beschränkung der Verwendung bestimmter gefährlicher Stoffe in Elektro- und Elektronikgeräten	2011/65/EU
Approximation of the laws of the Member States relating to electromagnetic compatibility and repealing Directive 89/336/EEC Angleichung der Rechtsvorschriften der Mitgliedstaaten über die elektromagnetische Verträglichkeit und zur Aufhebung der Richtlinie 89/336/EWG	2014/30/EU

**In order to testify the presumption of conformity the following standards were consulted:
Die Konformitätsvermutung wurde nach folgenden Standards überprüft:**

Title / Titel	EU Standard / -Norm
Information technology equipment - Immunity characteristics - Limits and methods of measurement Einrichtungen der Informationstechnik – Störfestigkeitseigenschaften - Grenzwerte und Prüfverfahren	EN55024:2011-09
Electromagnetic compatibility (EMC) - Part 4-8: Testing and measurement techniques - Power frequency magnetic field immunity test Elektromagnetische Verträglichkeit (EMV) - Teil 4-8: Prüf- und Messverfahren - Prüfung der Störfestigkeit gegen Magnetfelder mit energietechnischen Frequenzen	EN 61000-4-8:2009
Information technology equipment - Radio disturbance characteristics - Limits and methods of measurement Einrichtungen der Informationstechnik – Funkstöreigenschaften - Grenzwerte und Messverfahren	EN55022:2011-12

A BRAND OF SVS-VISTEK

MIKROTRON

High-Speed Vision Solutions

SVS-Vistek GmbH
Ferdinand-Porsche-Str. 3
82205 Gilching
Phone: +49 8105 3987-60
<https://www.svs-vistek.com>
info@svs-vistek.com

© 09-2022

This document and the product(s) described are subject to change without further notice.