

shr411CXGE

SHR 10GigE



The high resolution SHR series offers outstanding image quality. This is made possible by the excellent physical characteristics of large pixels in large format sensors. The thermally highly optimized housing guarantees highest optical precision. The large M72 lens mount can be adapted to any lens.

The economical and high-performance 10 GigE interface offers high data transfer speeds of up to 1.1 GB/s for these large images. A special frame grabber is not required.

Technical Highlights

- > User defined shading correction
- > Automatic and user defined pixel correction
- > High color depth
- > Extremely low noise
- > Excellent dynamic range
- > high performance 10GigE interface
- > Integrated 4-channel LED strobe controller
- > Industrial TTL-24V I/O Interface with SafeTrigger, programmable logic functions, sequencers and timers, RS232

SVS-Vistek GmbH - Ferdinand-Porsche-Str. 3 - 82205 Gilching - Germany - Telephone +49 8105 3987-60

Information accurate as to: 16.11.2022, errors and omissions excepted.

© 2022 – SVS-Vistek GmbH, all rights reserved.

SHR Series

shr411CXGE

Resolution [MP]	151 MP
Resolution (h x v)	14192 x 10640 px
Frame rate (max.)	6.1 fps
Chroma	color
Interface	10GigE
Sensor	
Sensor	IMX411AQR
Manufacturer	Sony
Sensor type	Area CMOS
Shutter type	rolling shutter
Sensor size (h x v)	53.36 x 40.01 mm
Optical diagonal	66.69 mm
Sensor format	Medium Format
Pixel size (h x v)	3.76 x 3.76 μm
Camera	
Exposure modes	MANUAL;AUTO;EXTERNAL
Trigger modes	INTERNAL;SOFTWARE;EXTERNAL
Exposure time (min)	60 μs
Exposure time (max)	1 sec (external ∞)
Pixel format / max	bayer8, bayer12, bayer16 / 16 bit
Gain modes / max	manual, auto / 36 dB
S/N ratio (max)	46.7 dB (dep. on environment)
Dynamic range (max)	82 dB (dep. on environment)
Internal memory	512 MB SDRAM
Feature Set	
Manual white balance	yes
Automatic white balance	yes
LUT	yes
Offset	yes
Binning	yes
Image flip	yes
Shading correction	yes (external)
Defect pixel correction	yes
Sequencer	yes
POE	yes (POE+)(optional)
Housing	
Lens mount	M72x0,75
Dimensions (w x h x d)	80 x 80 x 83 mm
Weight	580 g
Operating temperature (housing)	-10 to 70 °C
Ambient humidity	10 to 90 % (non-condensing)
Protection class	IP30
I/O-Interfaces	
Input up to 24V	2 x
Input OPTO	1 x

Dimensions [mm]

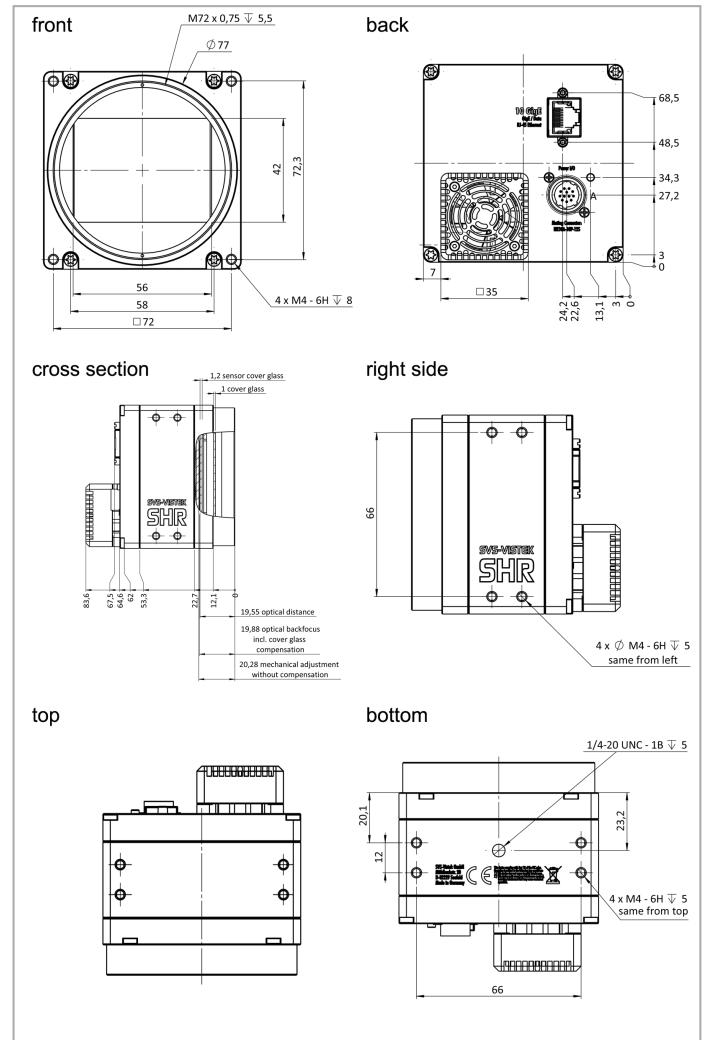

Pinout Mating Connector

Hirose 12 Pin	1	2	3	4	5	6	7	8	9	10	11	12
	VIN - (GND)	VIN + (10 V to 25 V DC)	IN 4 (RXD RS232)	OUT 4 (TXD RS232)	IN 1 (0-24V)	IN 2 (0-24V)	OUT 1 (open drain)	OUT 2 (open drain)	IN 3 + (opto In +)	IN 3 - (opto In -)	OUT 3 (open drain)	OUT 0 (open drain)

Spectral Response *

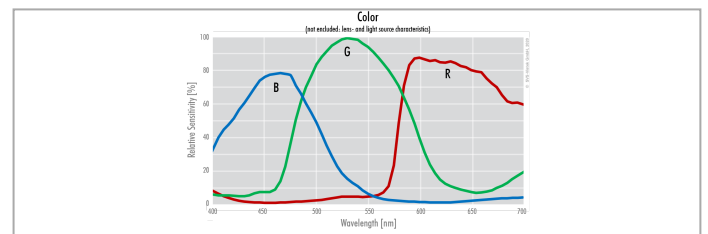

* Sensor data - excludes camera cover- or IR-cut filter characteristics

Output open drain	4 x
I/O RS-232	1 x
Power supply	10 to 25 V (DC)
Power consumption	17 W (dep. on operating mode)