

Linea ML Multiline Cameras

Monochrome / HDR CMOS ML-FM-08K30H, ML-FM-16K07A, ML-FM-16K15A,
ML-HM-08K30H and ML-HM-16K30H

sensors | **cameras** | frame grabbers | processors | software | vision solutions

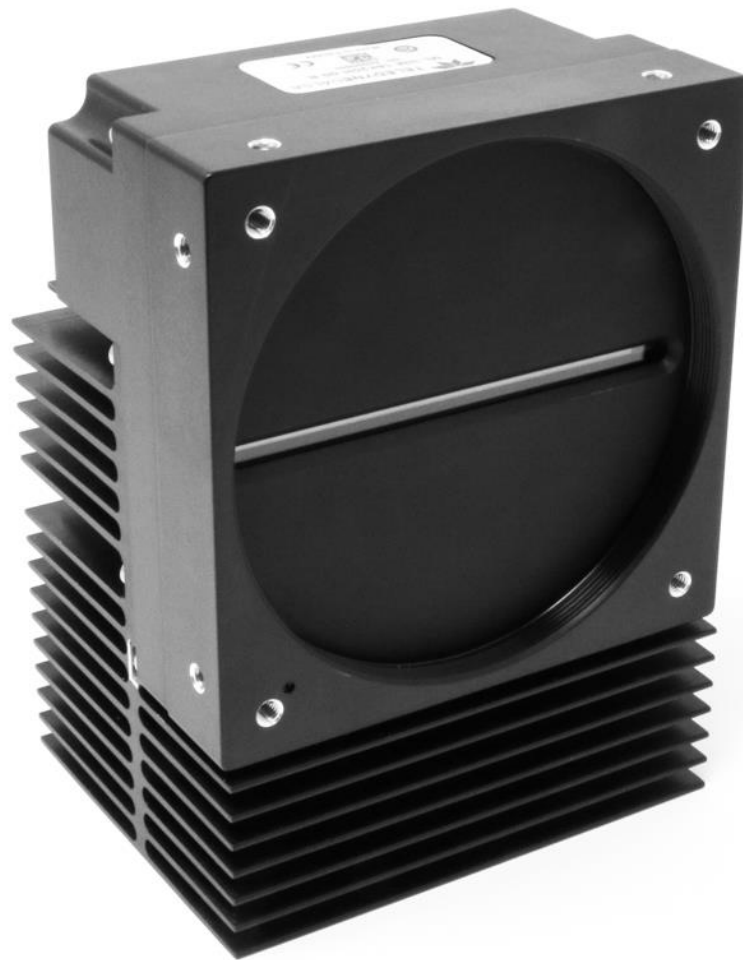

03-032-20263-03
www.teledynedalsa.com



TELEDYNE DALSA
Everywhereyoulook™

Part of the Teledyne Imaging Group

Notice

© 2019-2023 Teledyne Digital Imaging Inc.

All information provided in this manual is believed to be accurate and reliable. No responsibility is assumed by Teledyne Digital Imaging for its use. Teledyne Digital Imaging reserves the right to make changes to this information without notice. Reproduction of this manual in whole or in part, by any means, is prohibited without prior permission having been obtained from Teledyne Digital Imaging.

Microsoft and Windows are registered trademarks of Microsoft Corporation in the United States and other countries. Windows, Windows 7, Windows 8 are trademarks of Microsoft Corporation.

All other trademarks or intellectual property mentioned herein belong to their respective owners.

Document date: January 23, 2023

Document number: 03-032-20263-03

About Teledyne DALSA

Teledyne DALSA, a business unit of Teledyne Digital Imaging Inc., is an international high-performance semiconductor and Electronics Company that designs, develops, manufactures, and markets digital imaging products and solutions, in addition to providing wafer foundry services.

Teledyne DALSA offers the widest range of machine vision components in the world. From industry-leading image sensors through powerful and sophisticated cameras, frame grabbers, vision processors and software to easy-to-use vision appliances and custom vision modules.

This document does not contain information whose export/transfer/disclosure is restricted by the Canadian Export Control regulation.

Contents

| | |
|--|-----------|
| LINEA ML MULTILINE MONOCHROME / HDR CMOS CAMERAS | 6 |
| DESCRIPTION | 6 |
| CAMERA HIGHLIGHTS | 7 |
| <i>Key Features</i> | 7 |
| <i>Programmability</i> | 7 |
| <i>Applications</i> | 7 |
| PART NUMBERS AND SOFTWARE REQUIREMENTS | 8 |
| PERFORMANCE SPECIFICATIONS | 9 |
| <i>Flash Memory Size</i> | 10 |
| <i>Certification & Compliance</i> | 10 |
| CAMERA PIXEL ARRANGEMENT | 11 |
| CAMERA PROCESSING CHAIN | 12 |
| SUPPORTED INDUSTRY STANDARDS | 12 |
| <i>GenICam™</i> | 12 |
| <i>Camera Link HS</i> | 12 |
| <i>Data Cables</i> | 13 |
| RESPONSIVITY & QE PLOTS | 15 |
| MECHANICAL DRAWINGS | 16 |
| PRECAUTIONS | 20 |
| <i>Electrostatic Discharge and the CMOS Sensor</i> | 20 |
| INSTALL & CONFIGURE FRAME GRABBER & SOFTWARE | 21 |
| <i>Using Sapera CamExpert</i> | 21 |
| <i>CamExpert Panes</i> | 22 |
| SETTING UP FOR IMAGING | 24 |
| <i>Powering the Camera</i> | 24 |
| <i>Power and GPIO Connections</i> | 25 |
| <i>Establishing Camera Communications</i> | 28 |
| <i>Selecting the Data Format</i> | 28 |
| <i>Establishing Data Integrity</i> | 28 |
| CAMERA PERFORMANCE AND FEATURES | 29 |
| SYNCHRONIZING TO OBJECT MOTION | 29 |
| <i>Acquiring Images: Triggering the Camera</i> | 29 |
| <i>Measuring Line Rate (Trigger)</i> | 30 |
| <i>Maximum Line Rate</i> | 30 |
| <i>Minimum Line Rate</i> | 30 |
| <i>Scan Direction</i> | 30 |
| <i>Camera Orientation</i> | 32 |
| <i>Compensating for Encoder Errors (Spatial Correction)</i> | 33 |
| <i>Parallax Correction: Using the Camera at Non-Perpendicular Angles to the Object</i> | 35 |
| ESTABLISHING THE DESIRED RESPONSE | 37 |
| <i>Exposure Mode</i> | 37 |
| <i>Line Rate Jitter</i> | 37 |
| <i>Exposure Control</i> | 37 |
| <i>Exposure Time Selector</i> | 38 |
| <i>Sequential Mode Application Example</i> | 39 |

| | |
|--|-----------|
| <i>Exposure Mode Sequential</i> | 40 |
| <i>Adjusting Responsivity</i> | 42 |
| <i>Image Response Uniformity & Flat Field Calibration</i> | 42 |
| <i>Saving & Rapidly Loading a PRNU Set Only</i> | 43 |
| <i>Setting Custom Flat Field Coefficients</i> | 43 |
| <i>Flat Field Calibration Filter</i> | 44 |
| <i>Flat Field Calibration Regions of Interest</i> | 44 |
| TDI STAGE SELECTIONS AND FULL WELL | 45 |
| <i>HDR Demo Mode</i> | 46 |
| BINNING | 47 |
| <i>Using Area of Interest to Reduce Image Data & Enhance Performance</i> | 48 |
| <i>Steps to Setup Area of Interest</i> | 48 |
| <i>Rules for Setting Areas of Interest</i> | 49 |
| CUSTOMIZED LINEARITY RESPONSE (LUT) | 49 |
| <i>How to Generate LUT with CamExpert</i> | 50 |
| ADJUSTING RESPONSIVITY AND CONTRAST ENHANCEMENT | 51 |
| CHANGING OUTPUT CONFIGURATION | 52 |
| <i>Pixel Format</i> | 52 |
| USING TWO CLHS CABLES | 52 |
| SAVING & RESTORING CAMERA SETUP CONFIGURATIONS | 53 |
| <i>Active Settings for Current Operation</i> | 54 |
| <i>User Setting</i> | 54 |
| <i>Factory Settings</i> | 54 |
| <i>Default Setting</i> | 54 |
| APPENDIX A: GENICAM COMMANDS | 55 |
| CAMERA INFORMATION CATEGORY | 56 |
| <i>Camera Information Feature Descriptions</i> | 56 |
| <i>Built-In Self-Test Codes (BIST)</i> | 57 |
| <i>Camera Power-Up Configuration Selection Dialog</i> | 58 |
| <i>Camera Power-up Configuration</i> | 58 |
| <i>User Set Configuration Management</i> | 58 |
| CAMERA CONTROL CATEGORY | 59 |
| <i>Camera Control Feature Descriptions</i> | 60 |
| DIGITAL I / O CONTROL CATEGORY | 63 |
| <i>Digital I/O Control Feature Descriptions</i> | 63 |
| FLAT FIELD CATEGORY | 66 |
| <i>Flat Field Control Feature Descriptions</i> | 66 |
| IMAGE FORMAT CONTROL CATEGORY | 69 |
| <i>Image Format Control Feature Description</i> | 69 |
| TRANSPORT LAYER CONTROL CATEGORY | 71 |
| <i>Transport Layer Feature Descriptions</i> | 71 |
| ACQUISITION AND TRANSFER CONTROL CATEGORY | 73 |
| <i>Acquisition and Transfer Control Feature Descriptions</i> | 73 |
| FILE ACCESS CONTROL CATEGORY | 74 |
| <i>File Access Control Feature Descriptions</i> | 74 |
| <i>File Access via the CamExpert Tool</i> | 76 |
| <i>CLHS File Transfer Protocol</i> | 77 |
| <i>Download a List of Camera Parameters</i> | 78 |
| APPENDIX B: TROUBLESHOOTING GUIDE | 79 |
| DIAGNOSTIC TOOLS | 79 |
| <i>Camera Data File</i> | 79 |

| | |
|---|-----------|
| <i>Voltage & Temperature Measurement</i> | 79 |
| <i>Test Patterns – What Can They Indicate?</i> | 79 |
| <i>Built-In Self-Test Codes</i> | 80 |
| RESOLVING CAMERA ISSUES | 81 |
| <i>Communications:</i> | 81 |
| <i>Image Quality Issues</i> | 82 |
| <i>Power Supply Issues</i> | 86 |
| <i>Causes for Overheating & Power Shut Down</i> | 87 |
| DECLARATIONS OF CONFORMITY | 88 |
| <i>FCC Statement of Conformance</i> | 88 |
| <i>CE and UKCA Declaration of Conformity</i> | 88 |
| DOCUMENT REVISION HISTORY | 89 |
| CONTACT INFORMATION | 90 |
| SALES INFORMATION | 90 |
| TECHNICAL SUPPORT | 90 |

Linea ML Multiline Monochrome / HDR CMOS Cameras

Description

Teledyne DALSA introduces a breakthrough multiline CMOS line scan camera format with unprecedented speed, responsivity and exceptionally low noise.

The Linea ML™ multiline monochrome / HDR cameras have 8k or 16k pixel resolution, a 5 µm x 5 µm pixel size, and are compatible with fast, high magnification lenses.

The camera uses the Camera Link HS™ interface—the industry standard for very high speed camera interfaces with long transmission distances and cable flexing requirements (LC or CX4, resolution dependent).

Teledyne DALSA's Linea ML cameras and compatible frame grabbers combine to offer a complete solution for the next generation of automatic optical inspection (AOI) systems.

This camera is recommended for detecting small defects at high speeds and over a large field of view in LCD and OLED flat panel displays, printed circuit boards, film, printed material and large format web materials.

Available Camera Models

| Part Number | Description |
|-------------------|---|
| ML-FM-08K30H-00-R | 8,192 x 4 pixels, a maximum line rate of 280 kHz (up to 300 kHz using AOI), 5 µm x 5 µm pixel size, mono / HDR output, CLHS LC fiber optic connector. |
| ML-FM-16K07A-00-R | 16,384 x 1 pixels, a maximum line rate of 70 kHz, 5 µm x 5 µm pixel size, mono output, CLHS LC fiber optic connector. |
| ML-FM-16K15A-00-R | 16,384 x 1 pixels, a maximum line rate of 140 kHz, 5 µm x 5 µm pixel size, mono output, CLHS LC fiber optic connector. |
| ML-HM-08K30H-00-R | 8,192 x 4 pixels, a maximum line rate of 300 kHz, 5 µm x 5 µm pixel size, mono / HDR output, CLHS CX4 connector. |
| ML-HM-16K30H-00-R | 16,384 x 4 pixels, a maximum line rate of 300 kHz, 5 µm x 5 µm pixel size, mono / HDR output, CLHS CX4 connector. |

Camera Highlights

Key Features

- Highly responsive multiline CMOS
- 8K or 16K pixel resolution
- Up to 300 kHz line rates
- Very low noise
- Bi-directionality with fixed optical center
- Binning
- Robust Camera Link HS interface
- LC fiber optic or CX4 Camera Link HS control & data connector
- Smart lens shading correction
- High dynamic LUT mode

Programmability

- Spatial correction, including sub pixel adjustment
- Parallax correction
- Multiple areas of interest for data reduction
- Region of interest for easy calibration of lens and shading correction
- Test patterns & diagnostics

Applications

- Flat panel LCD and OLED display inspection
- Web inspection
- Printed circuit board inspection
- Printed materials
- High throughput and high-resolution applications

Part Numbers and Software Requirements

The camera is available in the following configurations:

Table 1: Camera Models Comparison

| Part Number | Resolution | Max. Line Rates | Pixel Size | Control & Data Connector |
|-------------------|-------------------|---|--------------|----------------------------------|
| ML-FM-08K30H-00-R | 8,192 x 4 pixels | 280 kHz monochrome 140 kHz x 2 HDR mode (300 kHz / 150 x 2 kHz using AOI) | 5.0 x 5.0 µm | Camera Link HS LC fiber optic |
| ML-FM-16K07A-00-R | 16,384 x 1 pixels | 70 kHz monochrome | 5.0 x 5.0 µm | Camera Link HS LC fiber optic |
| ML-FM-16K15A-00-R | 16,384 x 1 pixels | 140 kHz monochrome | 5.0 x 5.0 µm | Camera Link HS LC fiber optic |
| ML-HM-08K30H-00-R | 8,192 x 4 pixels | 300 kHz monochrome 150 kHz x 2 HDR mode | 5.0 x 5.0 µm | Camera Link HS CX4 |
| ML-HM-16K30H-00-R | 16,384 x 4 pixels | 300 kHz monochrome 150 kHz x 2 HDR mode | 5.0 x 5.0 µm | Camera Link HS CX4 |

Table 2: Frame Grabber

| Compatible Frame grabber | ML-FM-08K30H | ML-HM-16K30H ML-HM-08K30H | ML-FM-16K15A ML-FM-16K07A |
|--|---------------|------------------------------|------------------------------|
| Teledyne DALSA | OR-A8S0-FX840 | OR-A8S0-PX870 | OR-A8S0-FX840 |
| Other compatible frame grabbers may be available from third-party vendors. | | | |

Table 3: Software

| Software | Product Number / Version Number |
|---|--|
| Camera firmware | Embedded within camera |
| GenICam™ support (XML camera description file) | Embedded within camera |
| Sapera LT, including CamExpert GUI application and GenICam for Camera Link imaging driver | Latest version on the TeledyneDALSA Web site |

Performance Specifications

Table 4: Camera Performance Specifications

| Specifications | ML-HM-08K30H | ML-FM-08K30H | ML-HM-16K30H | ML-FM-16K07A ML-FM-16K15A |
|--|---|---|---|--|
| Imager Format | High speed CMOS multiline sensor | | | |
| Resolution | 8,192 x 4 pixels mono | | 16,384 x 4 pixels mono | 16,384 x 1 pixels mono |
| Pixel Size | 5.0 μm x 5.0 μm | | | |
| Pixel Fill Factor | 100 % | | | |
| Line Rate | 0 kHz to 300 kHz monochrome mode 150 kHz x 2 HDR mode | 0 kHz to 280 kHz monochrome mode 140 kHz x 2 HDR (300 / 150 kHz x 2 achievable using AOI) | 0 kHz to 300 kHz monochrome mode 150 kHz x 2 HDR mode | 16K07A = 70 kHz 16K15A = 140 kHz monochrome mode |
| Exposure Time | 3.2 μs to 1.4 ms | | | |
| Bit Depth | 8 bit or 12 bit, selectable | | | |
| Connectors and Mechanicals | ML-HM-08K30H | ML-FM-08K30H | ML-HM-16K30H | ML-FM-16K07A ML-FM-16K15A |
| Control & Data | Camera Link HS CX4 | Camera Link HS LC fiber optic | Camera Link HS CX4 | Camera Link HS LC fiber optic |
| Power | +12 V to +24 V DC, Hirose 12-pin circular | | | |
| Typical Power Dissipation | 15 W | 15 W | 25 W | 21 W |
| Size | 76 (W) x 76 (H) x 85 (D) mm | 76 (W) x 76 (H) x 85 (D) mm | 97 (W) x 140.5 (H) x 78.6 (D) mm | 97 (W) x 140.5 (H) x 78.6 (D) mm |
| Mass | < 500 g | < 500 g | 1.2 kg | 1.2 kg |
| Operating Temp | +0 °C to +65°C, front plate temperature | | | |
| Optical Interface | ML-HM-08K30H | ML-FM-08K30H | ML-HM-16K30H | ML-FM-16K07A ML-FM-16K15A |
| Lens Mount | M58 x 0.75 mm | M58 x 0.75 mm | M90 x 1 mm | M90 x 1 mm |
| Sensor to Camera Front Distance | 12 mm | | | |
| Sensor Alignment (aligned to sides of camera) | | | | |
| Flatness | 50 μm | | | |
| \ominus y (parallelism) | 100 μm | | | |
| x | \pm 300 μm | | | |
| y | \pm 300 μm | | | |
| z | \pm 300 μm | | | |
| \ominus z | \pm 0.4° | | | |

| Operating Ranges | Performance (ML-FM-08K30H, ML-HM-08K30H, ML-HM-16K30H) | ML-FM-16K07A ML-FM-16K15A |
|--|---|---------------------------------|
| Random Noise | < 0.3 DN rms, typical | |
| Peak Responsivity <i>Low Responsivity Line</i> <i>High Responsivity Line</i> | 3 DN / (nJ / cm ²) 18 DN / (nJ / cm ²) | 18 DN / (nJ / cm ²) |
| Gain | 1x to 10x | |
| DC Offset | 5 DN, can be adjusted as required | |
| Full Well <i>Low Responsivity Line</i> <i>High Responsivity Lines</i> | 44,000 e-, typical, single row 7,200 e-, typical, single row | 7,200 e-, typical, single row |
| PRNU | < ±2%, 50% of calibration target | |
| FPN | < ±2 DN | |
| SEE <i>Low Responsivity Line</i> <i>High Responsivity Lines</i> | 90 nJ / cm ² 14 nJ / cm ² | 14 nJ / cm ² |
| NEE <i>Low Responsivity Line</i> <i>High Responsivity Lines</i> | 100 pJ / cm ² 17 pJ / cm ² | 17 pJ / cm ² |
| Anti-blooming | > 100x Saturation | |
| Integral non-linearity | < 2% | |

*DN = digital number

Test Conditions unless otherwise specified:

- Values measured using 8 bit, 1x gain
- 40 kHz line rate
- Light source: White LED if wavelength not specified
- Front plate temperature: 45° C

| Environmental Specifications | |
|-----------------------------------|---|
| Storage temperature range | -20 °C to +80 °C |
| Humidity (storage and operation) | 15% to 85% relative, non-condensing |
| MTBF (mean time between failures) | >100,000 hours, typical field operation |

Flash Memory Size

Table 5: Camera Flash Memory Size

| Camera | Flash memory size |
|------------|-------------------|
| All models | 4 GByte |

Certification & Compliance

Table 6: Camera Certifications and Compliance

| Compliance |
|--|
| See Declarations of Conformity. |
| KC Registration |
| Verified equipment registered under the Clause 3, Article 58-2 of Radio Waves Act. ML-HM-16K30H registration no. R-R-Td2-ML-HM-16K30H. Registration date 2019-01-22. <i>ML-FM-08K30H registration pending.</i> |

Camera Pixel Arrangement

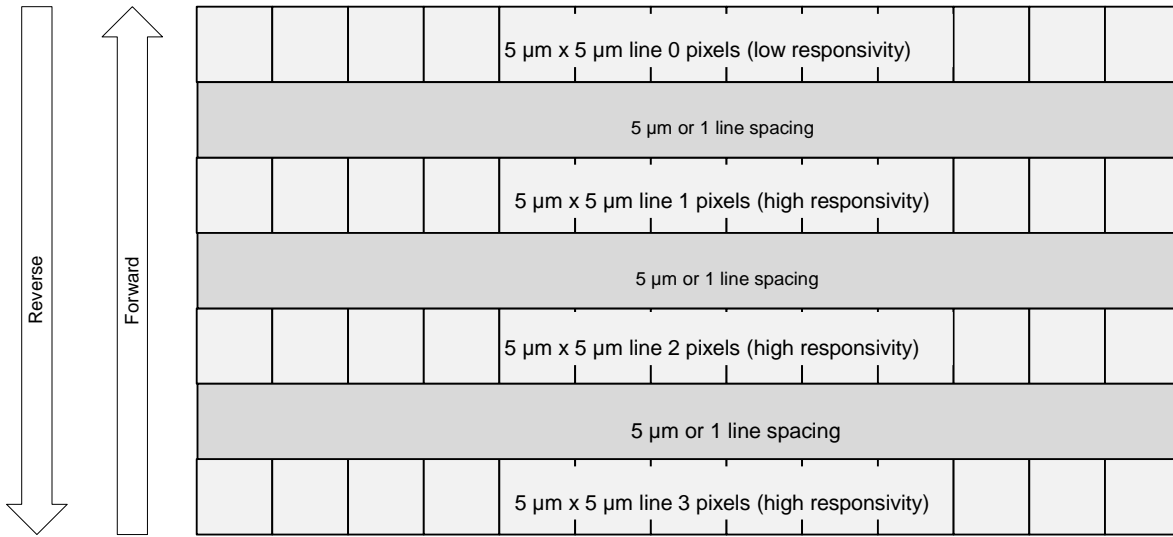

Figure 1: ML-FM-08K30H, ML-HM-08K30H and ML-HM-16K30H Pixel Structure

Forward and reverse imaging does not cause the optical center to change. Exposure control allows inspection speed to change without changing responsivity.

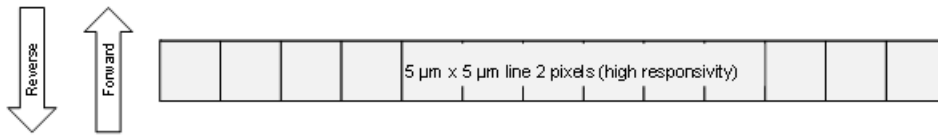
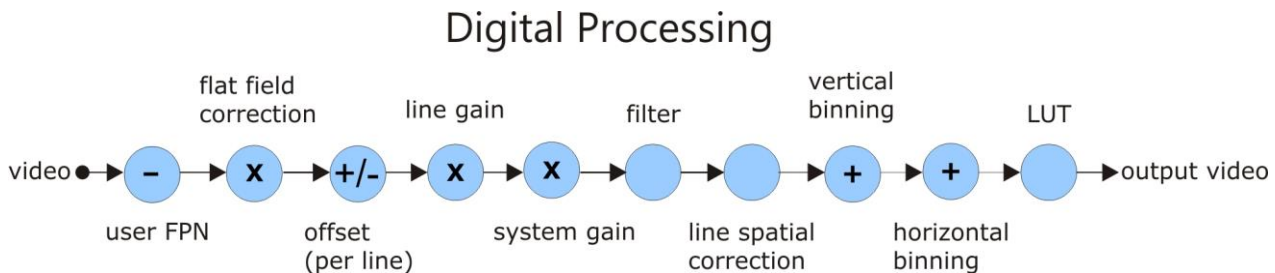

Figure 2: ML-FM-16K07A and ML-FM-16K15A Pixel Structure

The ML-FM-16K07A and ML-FM-16K15A cameras operate with a single high sensitivity line output only. There is no difference in camera operation when the scanning direction is changed.

Camera Processing Chain

The diagram below details the sequence of arithmetic operations performed on the camera's sensor data, which the user can adjust to obtain an optimum image for their application. These adjustments are performed using camera features outlined in the 'Review of Camera Performance and Features' section.



Supported Industry Standards

GenICam™

The camera is GenICam compliant and implements a superset of the GenICam Standard Features Naming Convention specification V1.5.

This description takes the form of an XML device description file using the syntax defined by the GenApi module of the GenICam specification. The camera uses the GenICam Generic Control Protocol (GenCP V1.0) to communicate over the Camera Link HS command lane.

For more information see www.emva.org/standards-technology/genicam/.

Camera Link HS

The camera is Camera Link HS version 1.0 compliant. Camera Link HS is the next generation of high-performance communications standards. It is used where an industrial digital camera interfaces with a single or multiple frame grabbers and with data rates exceeding those supported by the standard Camera Link.

The cameras come with two different output mediums. The ML-FM camera models use two LC connectors for data output. These two LC connectors are part of the SFP+ standard but in the case of Linea ML 8K camera the SFP+ modules are built into the camera. Either one or both SFP+ modules can be used but using only one SFP+ / fiber optic will sacrifice available bandwidth.

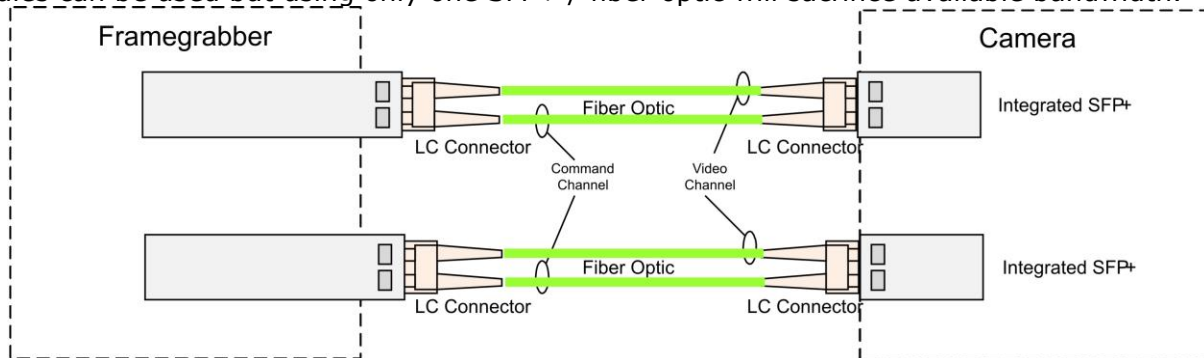

Figure 3. Linea ML Dual LC/SFP+ Connector Configuration

The ML-HM camera models use a CX4 connector for the output—using up to 5 lanes.

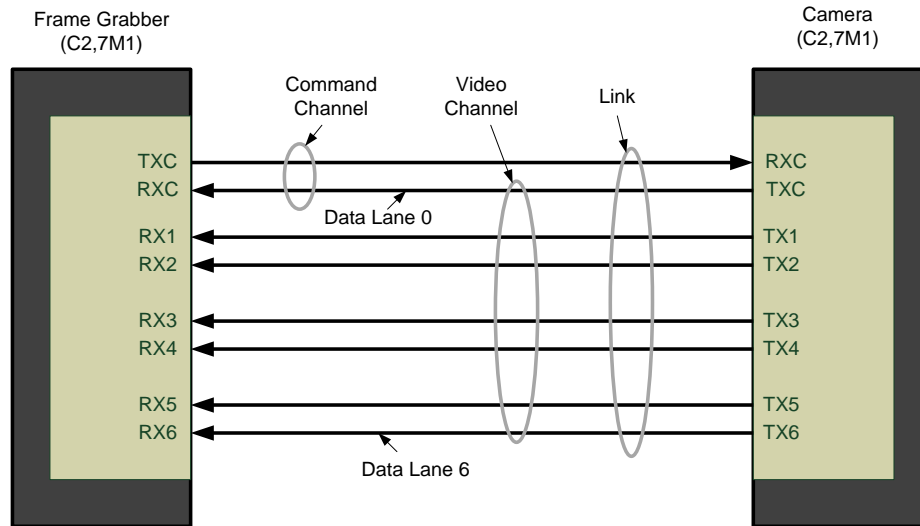

Figure 4. Single CLHS Connector Configuration

The command channel is used by the frame grabber to send commands, configuration and programming data to the camera and to receive command responses, status, and image data from the camera. With two SFP+ modules populated, the CLHS protocol will auto negotiate which one will be dedicated as the command channel. Data and command transmission is done with CLHS X protocol (64b / 66b) at the default speed of 10 Gbs.

Data Cables

LC Fiber Optic (ML-FM Cameras)

The fiber optic cables for the ML-FM camera models require LC connections on both ends of the cable. The frame grabber requires the LC connector to be plugged into a SFP+ transceiver module.

LC is a small-form factor fiber optic connector that uses a 1.25 mm ferrule, half the size of a standard connector. These cables are in wide use in the telecommunications industry and available in many lengths.

The distance through which the data can be transmitted depends on the type of fiber optic used.

Recommended fiber optic cables are types OM3 and OM4.

OM4 is used for distances > 300 m, but also requires SFP+ transceiver module changes.

Contact Teledyne DALSA Support for more information on recommended cables.

| Category | Fiber Diameter | Mode | Max Distance |
|----------|----------------|-----------|--------------|
| OM3 | 50 µm | Multimode | < 280 m |
| OM4 | 50 µm | Multimode | > 300 m |

CX4 AOC (ML-HM Cameras)

For the ML-HM camera models, the Camera Link HS CX4 AOC (Active Optical Cable) cables are made to handle very high data rates. These cables accept the same electrical inputs as traditional copper cables, but also use optical fibers. AOC uses electrical-to-optical conversion on the cable ends to improve speed and distance performance of the cable without sacrificing compatibility with standard electrical interfaces.

Camera Link HS cables can be bought from an OEM. OEM cables are also available for applications where flexing is present.

Please refer to Teledyne DALSA's website (www.teledynedalsa.com) for a list of recommended cable vendors and for part numbers.

Each data cable is used for sending image data to and accepting command data from the frame grabber. Command data includes GenICam compliant messages, trigger timing and general purpose I/O, such as direction control.



Note: data transmits at 10 Gbps which limits the effective distance of copper-based cables.

Responsivity & QE Plots

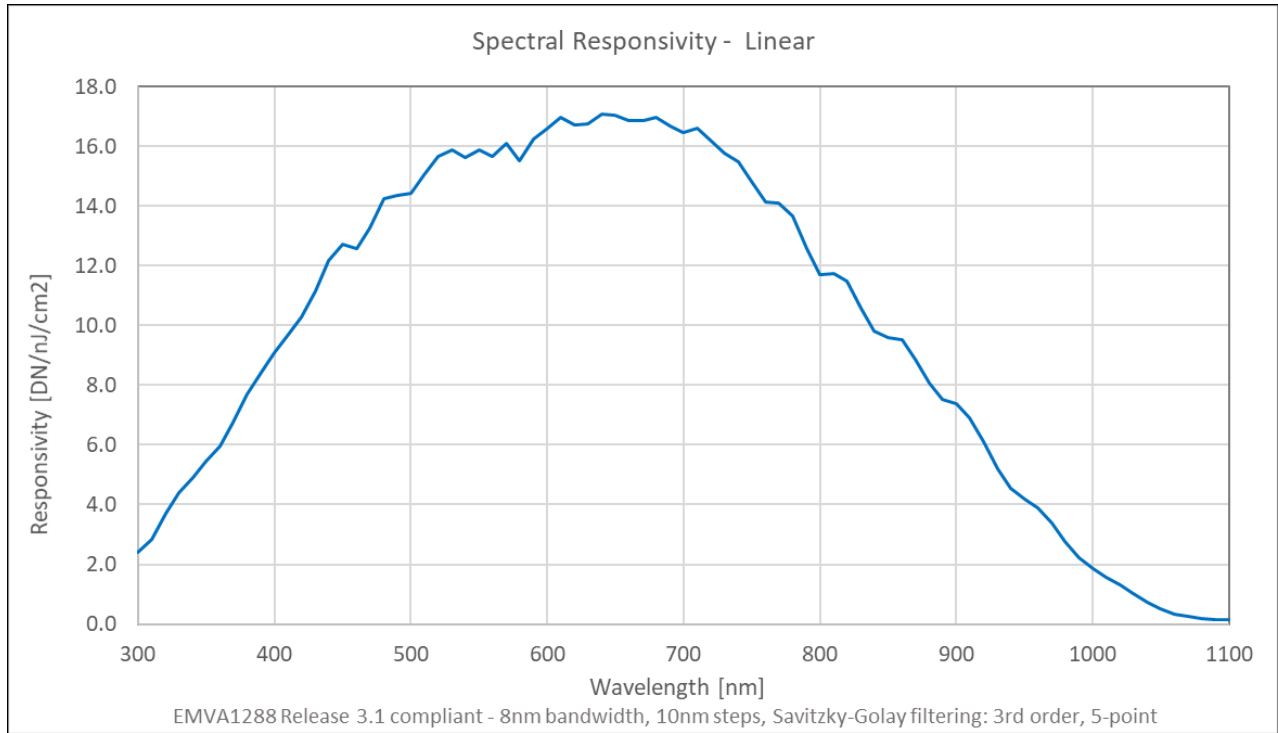

Figure 5. Camera Spectral Responsivity

Note: Responsivity values measured using 8-bit, 1x gain, single row.

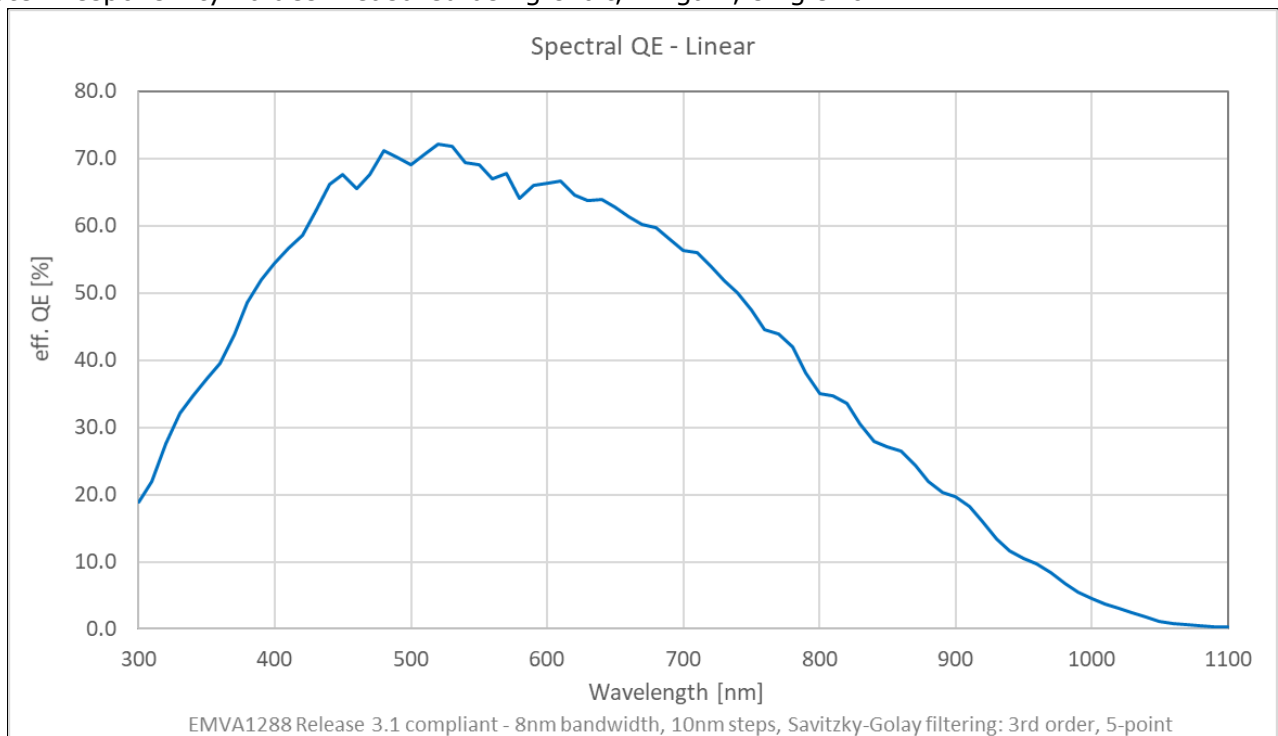

Figure 6. Camera Quantum Efficiency

Mechanical Drawings

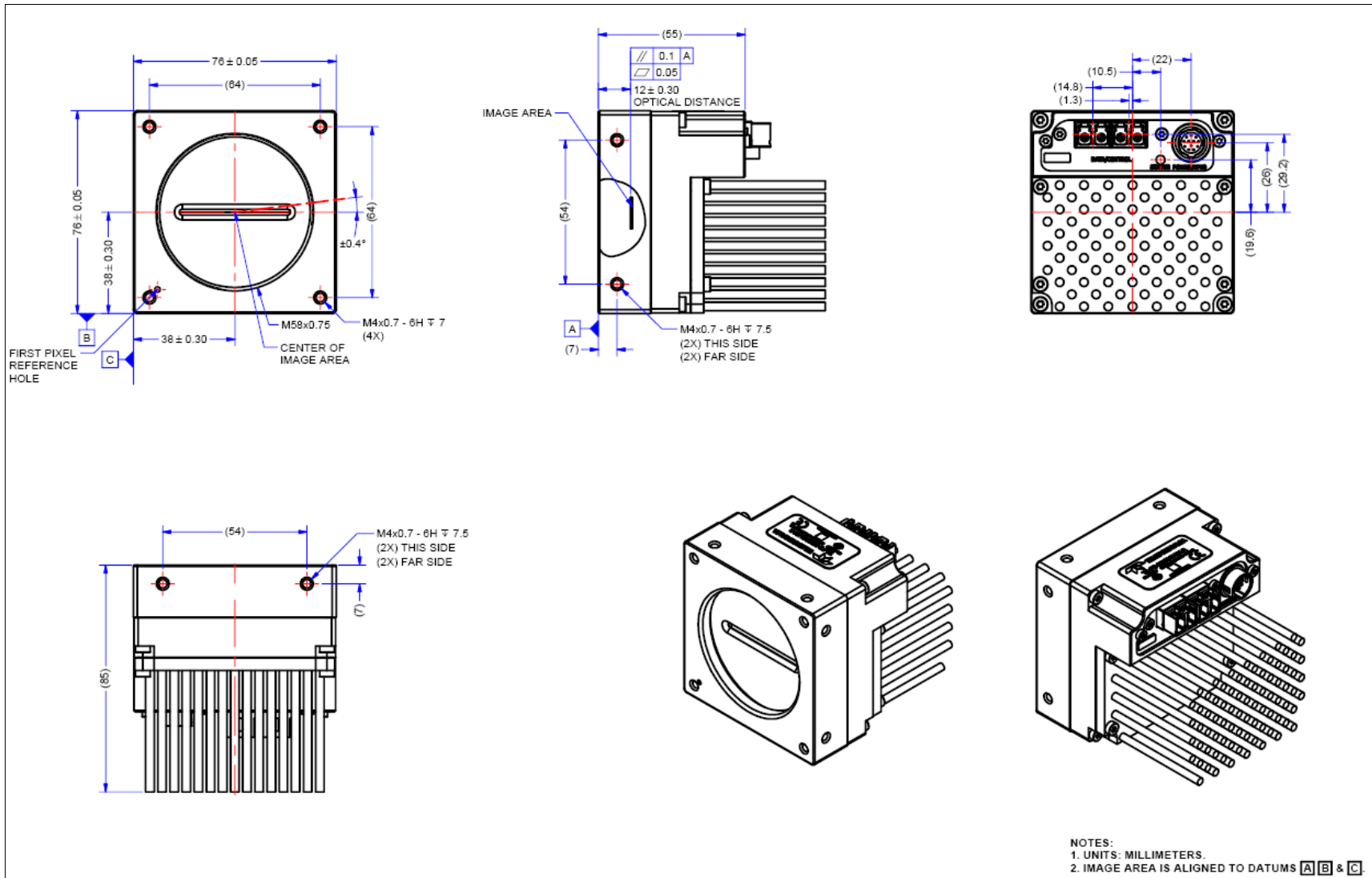

Figure 7. Linea ML-FM-8K Camera Mechanical

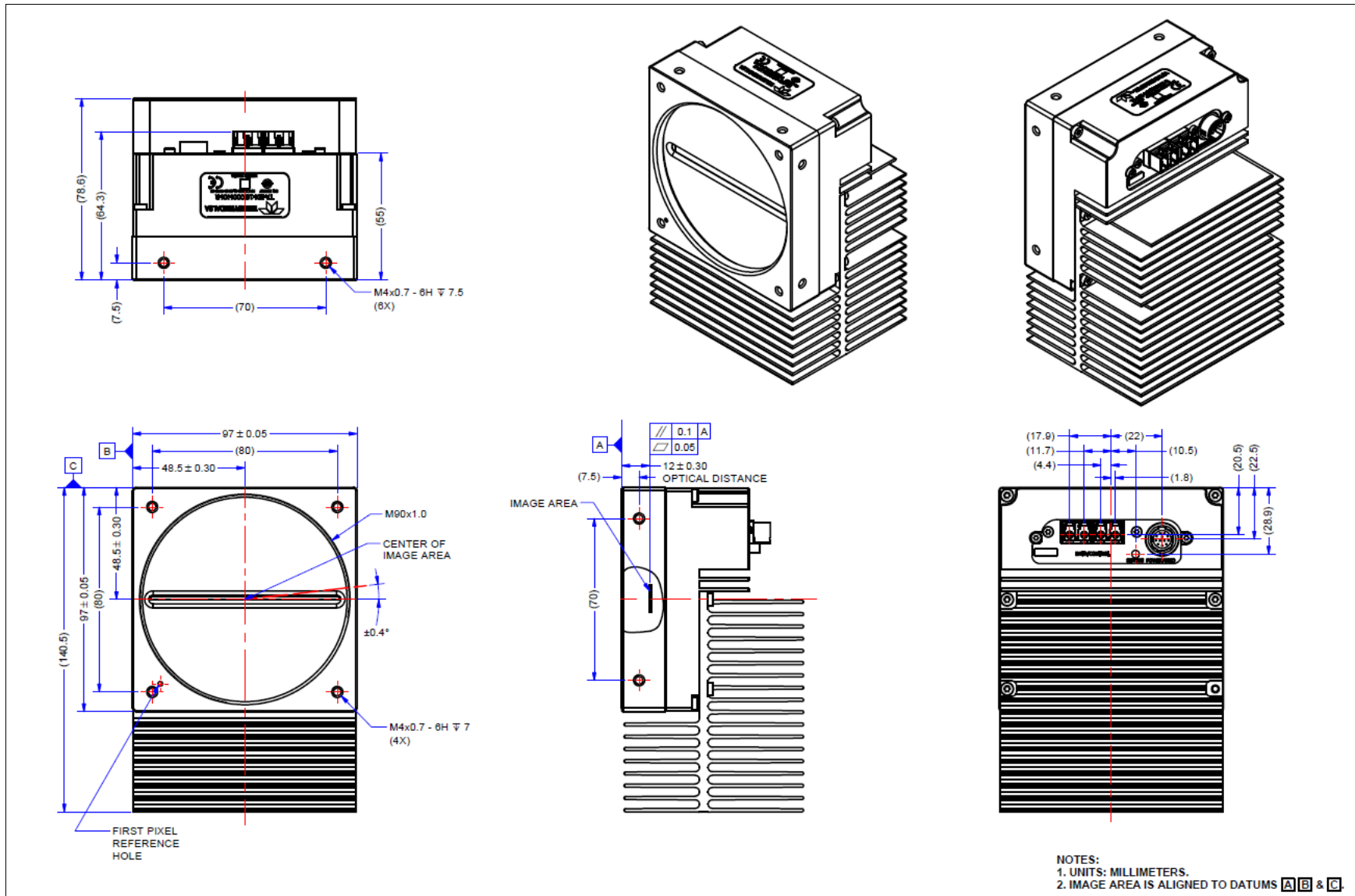

Figure 8. Linea ML-FM-16K Camera Mechanical

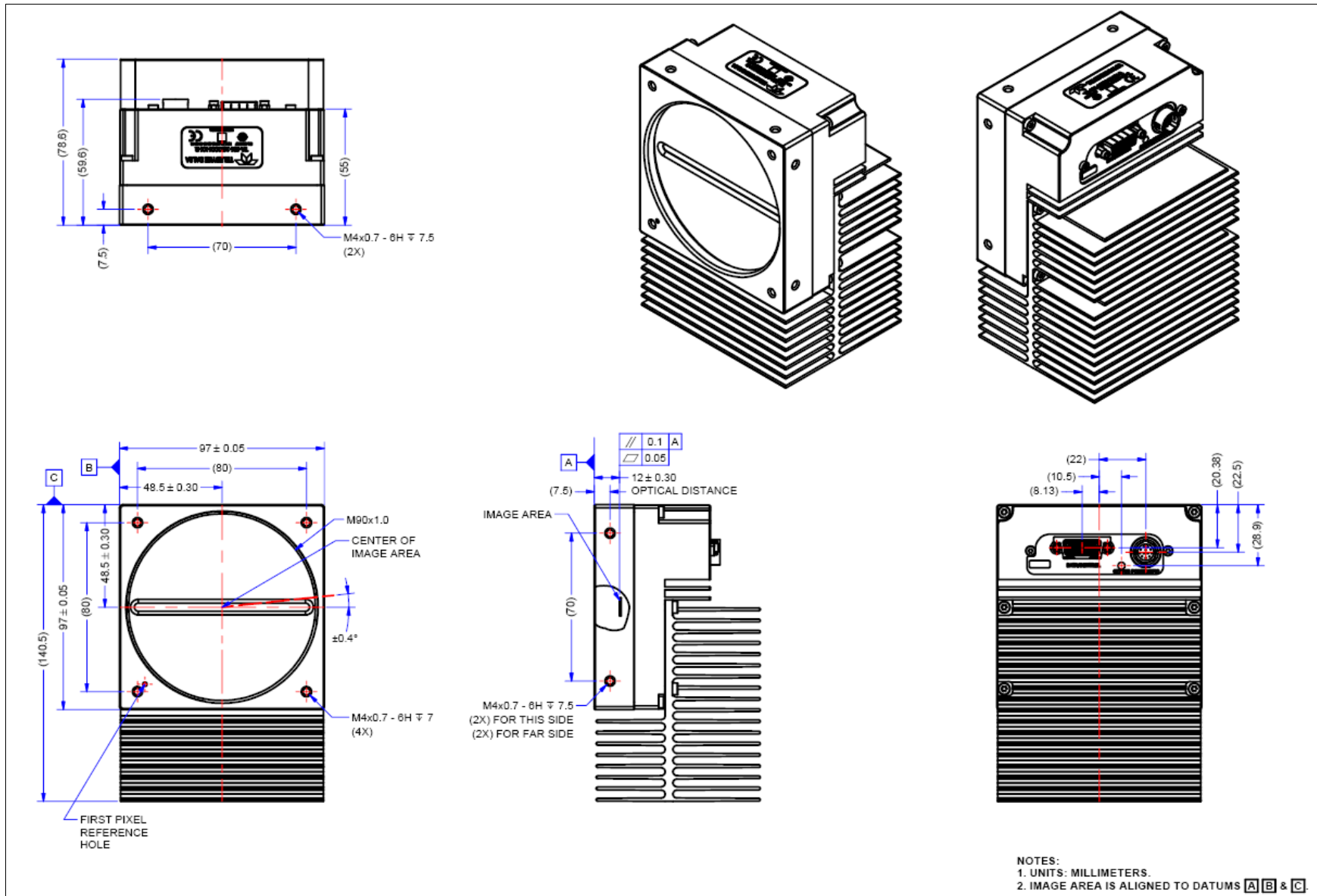

Figure 9. Linea ML-HM-16K Camera Mechanical

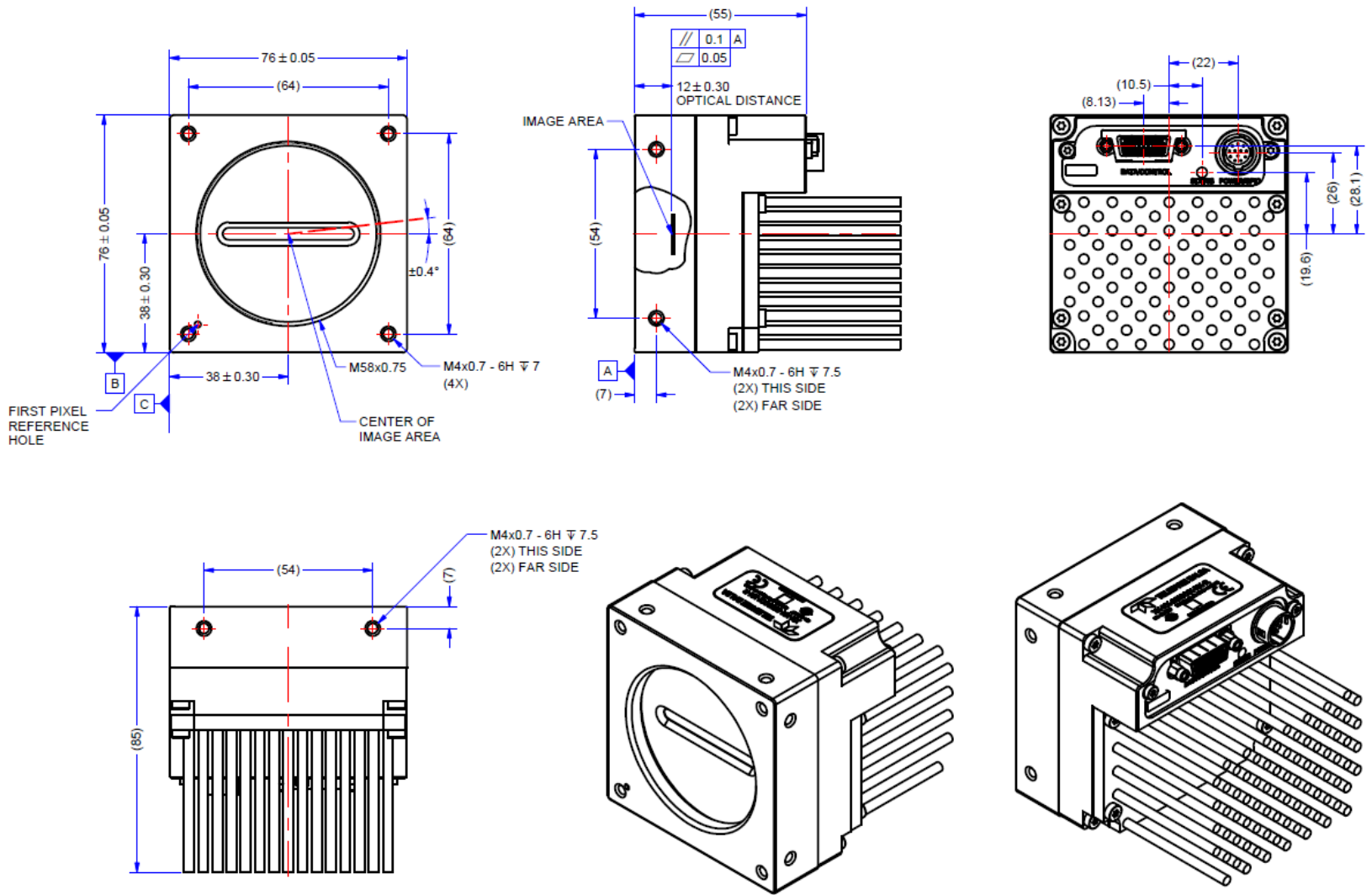

Figure 10: ML-HM-08K camera mechanical

Precautions

Read these precautions before using the camera.

Confirm that the camera's packaging is undamaged before opening it. If the packaging is damaged please contact the related logistics personnel.

Do not open the housing of the camera. The warranty is voided if the housing is opened.

Keep the camera's front plate temperature in a range of 0 °C to +65 °C during operation. The camera has the ability to measure its internal temperature. Use this feature to record the internal temperature of the camera when it is mounted in your system and operating under the worst case conditions. The camera will stop outputting data if its internal temperature reaches +80 °C.

Do not operate the camera in the vicinity of strong electromagnetic fields. In addition, avoid electrostatic discharging, violent vibration and excess moisture.

To clean the device, avoid electrostatic charging by using a dry, clean absorbent cotton cloth dampened with a small quantity of pure alcohol. Do not use methylated alcohol. To clean the surface of the camera housing, use a soft, dry cloth. To remove severe stains use a soft cloth dampened with a small quantity of neutral detergent and then wipe dry. Do not use volatile solvents such as benzene and thinners, as they can damage the surface finish.

Though this camera supports hot plugging, it is recommended that you power down and disconnect power to the camera before you add or replace system components.

Electrostatic Discharge and the CMOS Sensor

Image sensors and the camera's housing can be susceptible to damage from severe electrostatic discharge (ESD). Electrostatic charge introduced to the sensor window surface can induce charge buildup on the underside of the window. The charge normally dissipates within 24 hours and the sensor returns to normal operation.

Install & Configure Frame Grabber & Software

Because of the high bandwidth required by these cameras, we recommend a compatible Teledyne DALSA frame grabber (part numbers: OR-A8S0-FX840 (ML-FM) or OR-A8S0-PX870 (ML-HM)), or equivalent, described in detail on the teledynedalsa.com site [here](#).

The frame grabber requirements for the various camera models are different. Follow the manufacturer's installation instructions.

A GenICam compliant XML device description file is embedded with the camera firmware and allows GenICam compliant applications to recognize the camera's capabilities once connected.

Installing Sopera LT gives you access to the CamExpert GUI, a GenICam compliant application.

Using Sopera CamExpert

CamExpert is the camera interfacing tool supported by the Sopera library. When used with the camera, CamExpert allows a user to access a camera's features and parameters, and to test the operating modes. In addition, CamExpert can be used to save the camera's user settings configurations to the camera or to save multiple configurations as individual camera parameter files on the host system (*.ccf). CamExpert can also be used to upgrade the camera's software.

An important component of CamExpert is its live acquisition display window. This window allows the user to verify the timing or control parameters in real-time, without needing to run a separate acquisition program.

A short description of the configuration parameter will be shown in a popup. Click on the  button to open the help file for more descriptive information on CamExpert.



Note: The availability of features depends on the CamExpert user setting. Not all features are available to all users. The examples shown are for illustrative purposes and may not entirely reflect the features and parameters available from the camera model used in your application.

CamExpert Panes

CamExpert, first instance: select Camera Link HS using the Device drop-down menu.

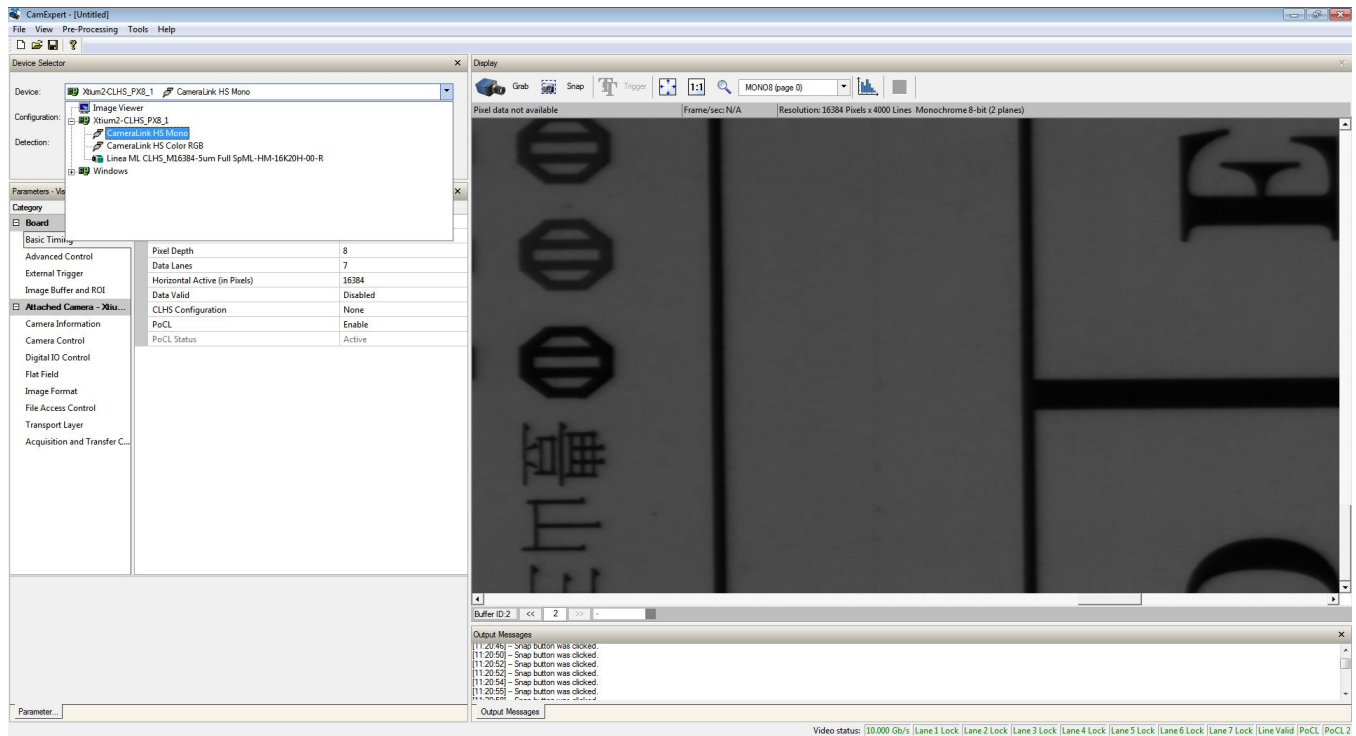

Figure 11. CamExpert Frame Grabber Control Window







The CamExpert application uses panes to organize the selection and configuration of camera files or acquisition parameters.

Device Selector pane: View and select from any installed Sapera acquisition device. Once a device is selected, CamExpert will only show acquisition parameters for that device. Optionally, select a camera file included with the Sapera installation or saved by the user.

Parameters pane: Allows the viewing or changing of all acquisition parameters supported by the acquisition device. CamExpert displays parameters only if those parameters are supported by the installed device. This avoids confusion by eliminating parameter choices when they do not apply to the hardware in use.

Display pane: Provides a live or single frame acquisition display. Frame buffer parameters are shown in an information bar above the image window.

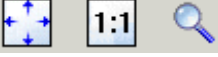
Control Buttons: The display pane includes CamExpert control buttons. These are:

| | |
|---|--|
|  Grab  Freeze | <p>Acquisition control button: Click once to start live grab, click again to stop.</p> |
|  Snap | <p>Single frame grab: Click to acquire one frame from device.</p> |
|  Trigger | <p>Trigger button: With the I/O control parameters set to Trigger Enabled, click to send a single trigger command.</p> |
|  | <p>CamExpert display controls: (these do not modify the frame buffer data) Stretch image to fit, set image display to original size, or zoom the image to virtually any size and ratio.</p> |
|  | <p>Histogram / Profile tool: Select to view a histogram or line/column profile during live acquisition or in a still image.</p> |

Output Message Pane: Displays messages from CamExpert or the device driver.

At this point you are ready to start operating the camera, acquire images, set camera functions, and save settings.

Setting Up for Imaging

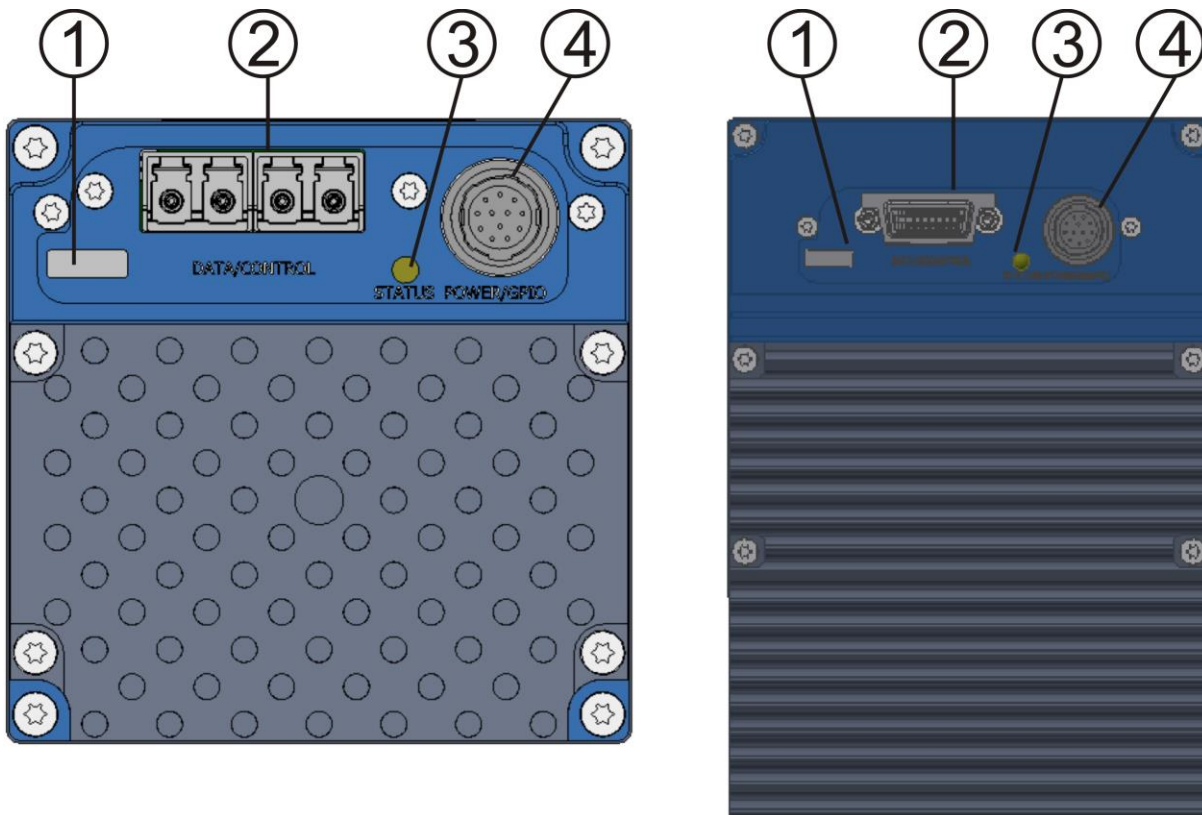

Figure 12. Camera I / O Connectors: ML-FM models (left) & ML-HM models (right).

Camera I / O Connectors

- 1) Factory use only.
- 2) Data and control connectors: LC or CX4 AOC.
- 3) LED status indicators.
- 4) Power and GPIO connectors: +12 V to +24 V DC, Hirose 12-pin circular.

Powering the Camera

WARNING: When setting up the camera's power supply follow these guidelines:

- Apply the appropriate voltages of between +12 V to +24 V. Incorrect voltages may damage the camera.
- Before connecting power to the camera, test all power supplies.
- Protect the camera with a 3 amp slow-blow fuse between the power supply and the camera.
- Do not use the shield on a multi-conductor cable for ground.
- Keep leads as short as possible in order to reduce voltage drop.
- Use high quality supplies in order to minimize noise.

- When using a 12 V supply, voltage loss in the power cables will be greater due to the higher current. Use the Camera Information category to refresh and read the camera's input voltage measurement. Adjust the supply to ensure that it reads above or equal to 12 V.



Note: If your power supply does not meet these requirements, then the camera performance specifications are not guaranteed.

Power and GPIO Connections

The camera uses a single 12-pin Hirose male connector for power, trigger and strobe signals. The suggested female cable mating connector is the *Hirose model HR10A-10P-12S*.

12-Pin Hirose Connector Signal Details

The following figure shows the pinout identification when looking at the camera's 12-pin male Hirose connector. The table below lists the I/O signal connections.

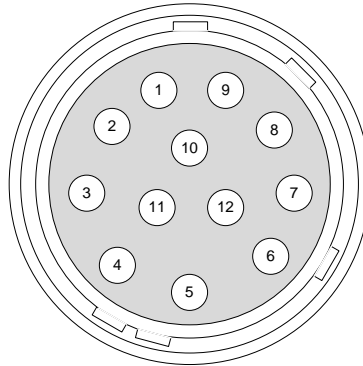

| Pin Number | Input / Output | Signal Details | Notes |
|------------|----------------|-----------------------------------|--|
| 1 | | Power Ground* | |
| 2 | | +12 V to +24 V power* | |
| 3 | Output | Line 3 Out | 0 to 3.3V TTL |
| 4 | Output | Line 4 Out | 0 to 3.3V TTL |
| 5 | Input | Line 1 / Trigger / Phase A | 0 to 3.3V TTL |
| 6 | Input | Line 2 / Scan Direction / Phase B | 0 to 3.3V TTL |
| 7 | Output | Line 5 Out | 0 to 3.3V TTL |
| 8 | Output | Line 6 Out | 0 to 3.3V TTL |
| 9 | | Power Ground* | |
| 10 | | +12 V to +24 V power* | |
| 11 | | Signal Ground | Note: intended as a return path for GPIO signal and not intended as a power ground |
| 12 | | Signal Ground | Note: intended as a return path for GPIO signal and not intended as a power ground |

*Connect all power pins. Each pin is rated 2A.

The wire gauge of the power cable should be sufficient to accommodate a surge during power-up of at least 3 amps with a minimum voltage drop between the power supply and camera. The camera can accept any voltage between +12 Volts and +24 Volts. If there is a voltage drop between the power supply and camera, ensure that the power supply voltage is at least 12 Volts plus this voltage drop. The camera input supply voltage can be read using CamExpert. Refer to the section on Voltage & Temperature Measurement for more details.

Mating GPIO Cable Assembly

Teledyne DALSA makes available for purchase an optional GPIO breakout cable (12-pin Female Hirose to 13-Pos Euro Block), as shown in the following drawing. Use accessory number #CR-GENC-IOP00 to order.

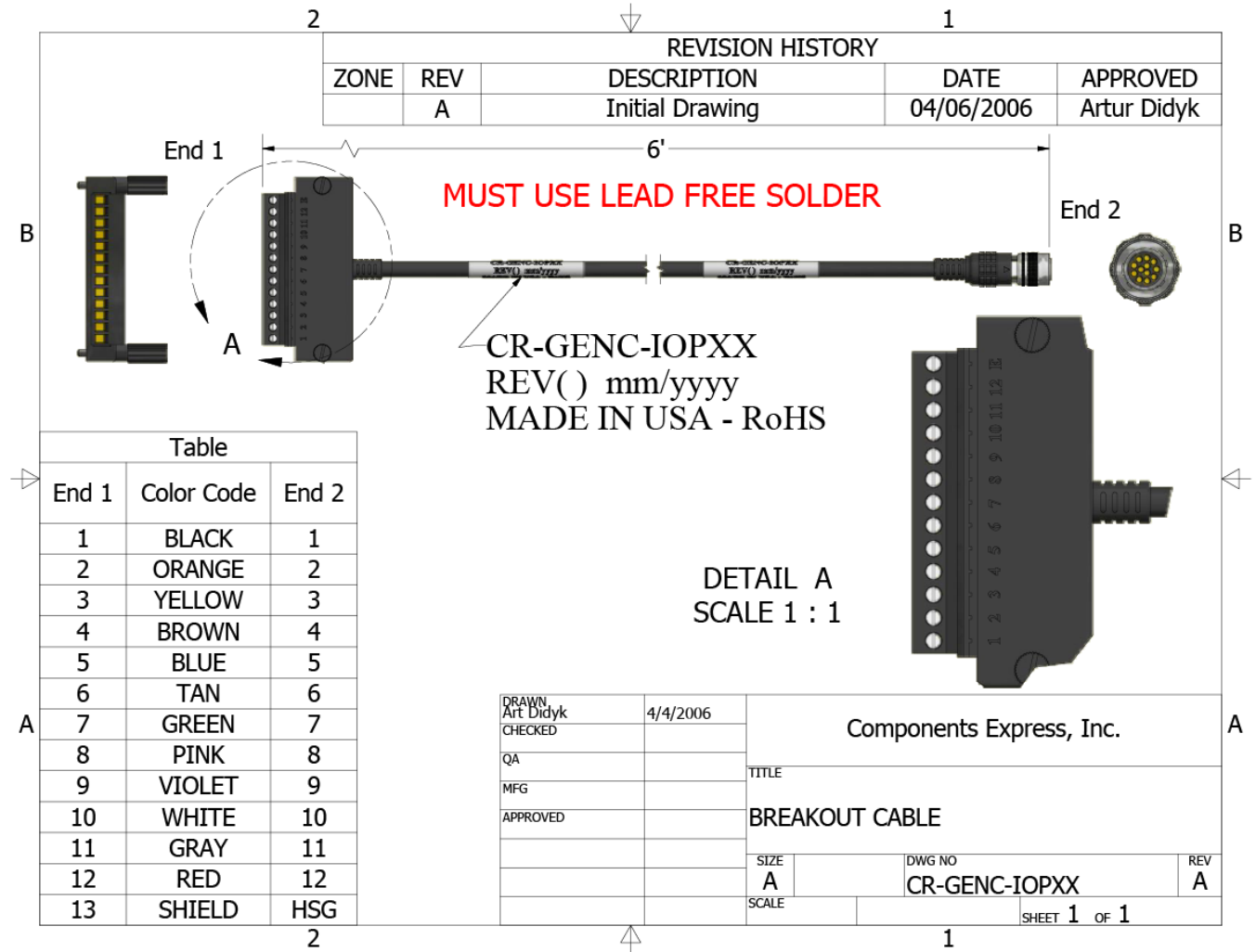

External Input Electrical Characteristics

| Input Level Standard | Switching Voltage | | Input Impedance |
|----------------------|-------------------|-------------|-----------------|
| | Low to high | High to low | |
| 3.3V TTL | 2.1V | 1V | 10K Ω |

External Input Timing Reference

| Input Level Standard | Maximum Input Frequency | Minimum Pulse Width | Input Current | Maximum Signal Propagation Delay @ 60°C | |
|----------------------|-------------------------|---------------------|---------------|---|---------|
| 3.3V TTL | 20 MHz | 25 ns | <250 μ A | 0 to 3.3V | <100 ns |
| | | | | 3.3V to 0 | <100 ns |

External Output Electrical Characteristics

| Output Level Standard | V _{OL} | V _{OH} |
|-----------------------|-----------------|-----------------|
| 3.3V TTL | <0.4V @ 10mA* | >3.1V @ 10mA* |

*See Linear Technology data sheet LTC2854

External Output Timing Reference

| Output Level Standard | Maximum Output Frequency | Minimum Pulse Width | Output Current | Maximum Signal Propagation Delay @ 60°C | |
|-----------------------|--------------------------|---------------------|----------------|---|---------|
| 3.3V TTL | Line rate dependent | 25 ns | <180 mA | 0 to 3.3V | <100 ns |
| | | | | 3.3V to 0 | <100 ns |



To reduce the chance of stress and vibration on the cables, we recommend that you use cable clamps, placed close to the camera, when setting up your imaging system. Stress or vibration of the heavy CLHS AOC cables may damage the camera's connectors.

Establishing Camera Communications

When you power up the camera, observe the LED status indication on the back. The LED will indicate one of the following status conditions:

| LED State | Description |
|-----------------|---|
| Off | Camera not powered up or waiting for the software to start |
| Constant Red | The camera BIST status is not good. See BIST status for diagnosis. |
| Blinking Red | The camera has stopped output and has shut down some components due to an over temperature condition. |
| Blinking Orange | Powering Up. The microprocessor is loading code. |
| Blinking Green | Hardware is good, but the CLHS connection has not been established or has been broken. |
| Constant Green | The CLHS Link has been established and data transfer may begin |

When the camera's LED state is steady green open CamExpert.

1. CamExpert will search for installed Sopera devices.
2. In the Devices list area on the left side of the window, the connected frame grabber will be shown.
3. Select the frame grabber device by clicking on the name.

In a change from previous versions of the Sopera GUI, only one instance of CamExpert is required to send commands to the camera and view images.

Selecting the Data Format

The camera can output data in the following formats:

Mono8

Mono12

Please refer to the frame grabber user's documentation for further details on selection of input and output pixel formats.

Establishing Data Integrity

1. Use the camera's internal triggering. This allows for initial imaging with a static object and no encoder input is required.
2. Enable the camera to output a test pattern.
3. Use CamExpert to capture, display and analyze the test pattern image to verify the integrity of the connection. If the test pattern is not correct, check the cable connections and the frame grabber setup.
4. Disable the test pattern output.

Camera Performance and Features

This section is intended to be a progressive introduction to the features of the camera, including explanations of how to use them effectively.

A detailed description of all features is found in Appendix A: GenICam Commands.

Synchronizing to Object Motion

Acquiring Images: Triggering the Camera

Related Features: [ExposureMode](#), [TriggerMode](#), [TriggerSource](#), [TriggerActivation](#)

A number of different methods that can be used to trigger image acquisition in the camera:

Internal Trigger

The simplest method is to set the Trigger Mode to "Internal". This results in the camera being triggered by an internal timer, which can be adjusted using the Acquisition Line Rate feature.

External Triggers

When the Trigger Mode command is set to "External", the triggers to the camera can come from different sources, set using the Trigger Source feature.

The available sources for the triggers are from pin 5 of the GPIO connector, from the Camera Link HS frame grabber, or from the rotary encoder feature (using pin 5 and pin 6 of the GPIO connector).

Use the Trigger Activation feature to select the edge or level that triggers the camera. The options are: Rising Edge, Falling Edge or Any Edge.

CamExpert can be used to configure the frame grabber for routing the encoder signal from the frame grabber input to the trigger input of the camera via the Camera Link HS data cable.

Line Rate & Synchronization

A continuous stream of encoder trigger pulses synchronized to the object motion establishes the line rate. The faster the object's motion is, the higher the line rate. The camera can accommodate up to its specified maximum frequency. If the maximum frequency is exceeded, the camera will continue to output image data at the maximum specified. The result will be that some trigger pulses will be missed and there will be an associated distortion (compression in the scan direction) of the image data. When the line rate returns to or below the maximum specified, then normal imaging will be reestablished.

Measuring Line Rate (Trigger)

See *Camera Control Category in Appendix A for GenICam features associated with this section and how to use them.*

Related Feature: [measuredLineRate](#)

The Measured Line Rate command is used to read the line (trigger) rate being applied, externally or internally, to the camera.

Maximum Line Rate

The maximum line rate that the camera can achieve is determined by the number of CLHS lanes used and by the number of cables installed, as shown in the following table:

| Maximum Line Rate (1 sensor line output, 8 bit) | | | |
|---|-----------------------|------------------------|---------------|
| Camera Model | One Fiber Optic Cable | Two Fiber Optic Cables | One AOC cable |
| ML-FM-08K30H-00-R | 140 kHz | 280 kHz | NA |
| ML-FM-16K07A-00-R | 70 kHz | 70 kHz | NA |
| ML-FM-16K15A-00-R | 71 kHz | 143 kHz | NA |
| ML-HM-08K30H-00-R | NA | NA | 300 kHz |
| ML-HM-16K30H-00-R | NA | NA | 300 kHz |

Minimum Line Rate

The minimum line rate for all camera models is 0 kHz. Cameras go to full stop without image anomaly.

Scan Direction

See the section *Camera Control Category in Appendix A for GenICam features associated with this section and how to use them*

Related Feature: [SensorScanDirectionSource](#), [sensorScanDirection](#)

A multiline camera requires the user to tell the camera the direction of travel of the object being imaged.

The scan direction is set using the `sensorScanDirectionSource` command. The options are: Internal, Line 2 (pin 6 on the GPIO connector), and the rotary encoder feature (using pin 5 and pin 6 of the GPIO connector).

When set to internal, use the `sensorScanDirection` feature to set the direction.

Direction Change Time

The direction change time between forward and reverse is < 1 ms.

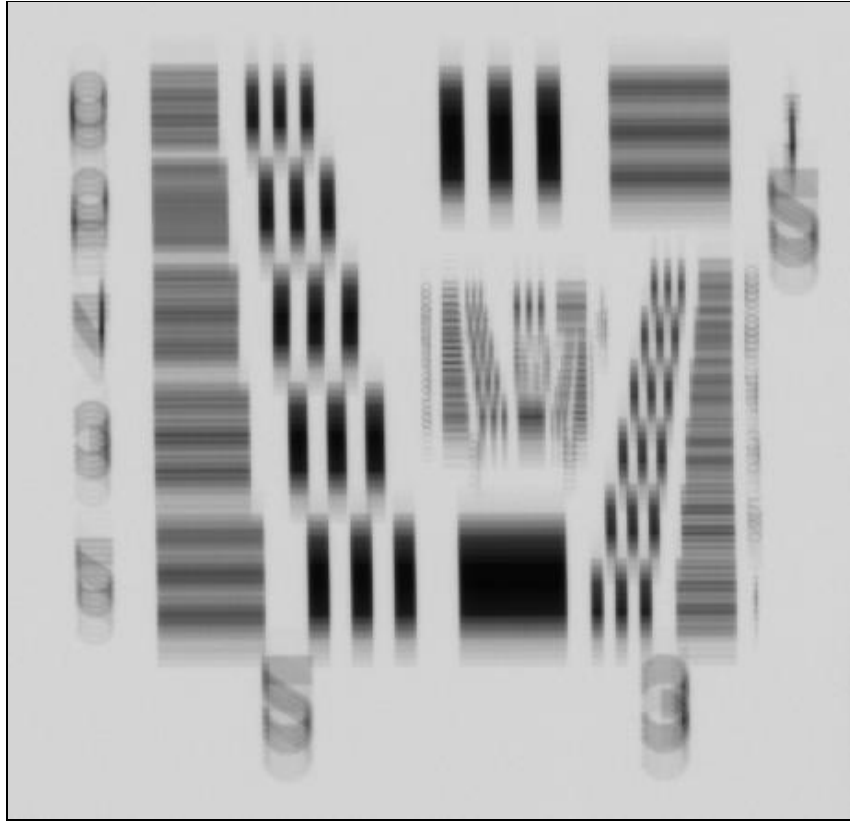



Figure 13. Image with incorrect scan direction

Camera Orientation

The diagram below shows the orientation of forward and reverse with respect to the camera body.



Note: The diagram assumes the use of a lens on the camera, which inverts the image.

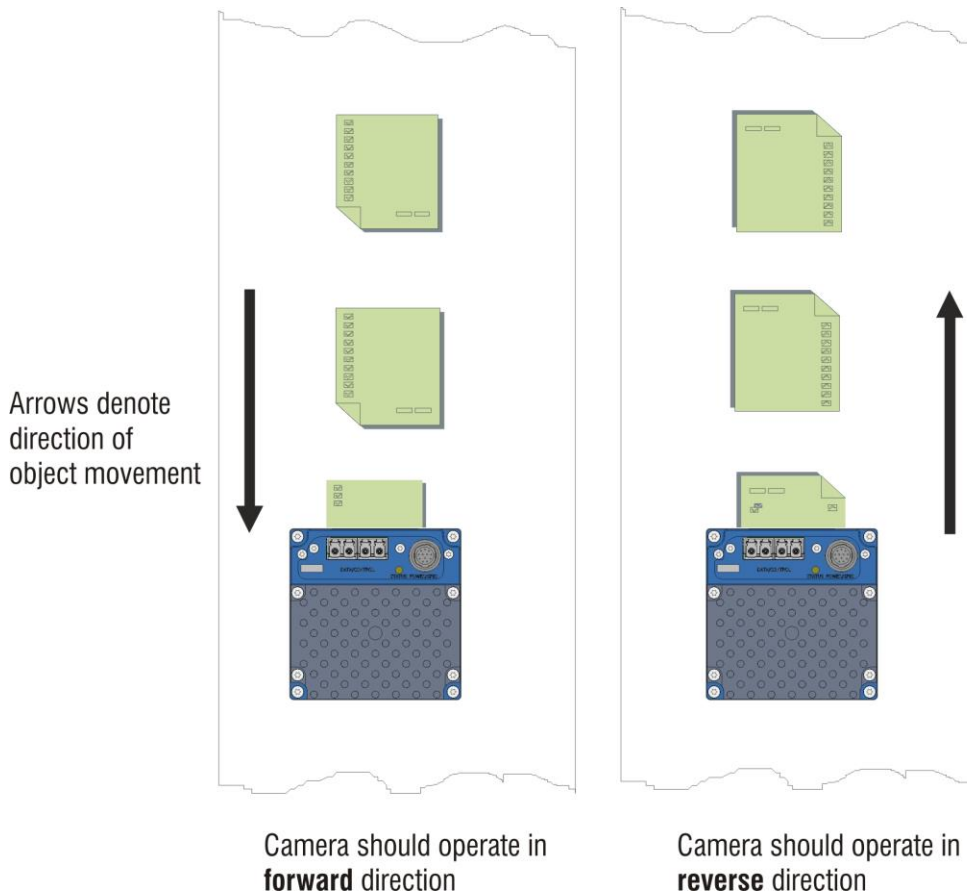

Figure 14: Example of Object Movement and Camera Direction (8K camera shown)

The diagram shows the designated camera direction. However, due to the characteristics of the lens, the direction of the objects motion is opposite to the image motion direction.

Some AOI systems require that the scan direction change at regular intervals. For example, scanning a panel forwards, coming to a stop, and then scanning backward as the camera's field of view is progressively indexed over the entire panel.

It is necessary for the system to over-scan the area being imaged, including the lines that are not valid, as a result of the direction change. This ensures that valid data will be generated on the return path as the camera's field of view reaches the area to be inspected.

Compensating for Encoder Errors (Spatial Correction)

See *Camera Control Category* in Appendix A for GenICam features associated with this section and how to use them.

Related Feature: [sensorLineSpatialCorrection](#)

To achieve a sharp image in the vertical direction when running the camera in TDI mode or in HDR mode it is important that the lines being used are aligned correctly. The line spatial correction feature is used to ensure that these lines align.

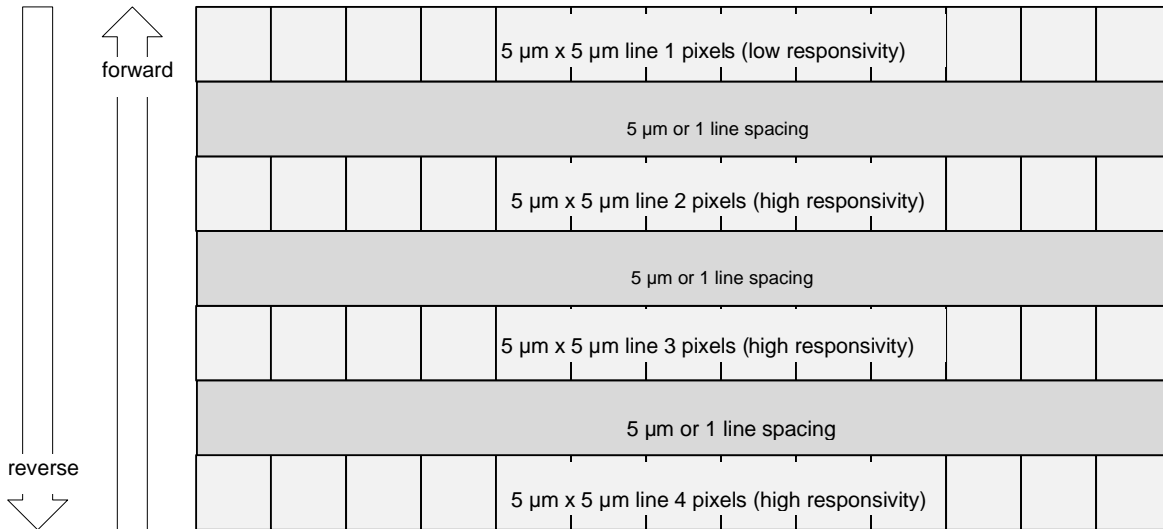

Figure 15. Camera Line spacing

The camera ensures the scan direction alignment of the lines by delaying the image data for each line a set amount of time, as dictated by the scan direction.

Assuming that the encoder generates a pulse that is equal to the object pixel, Line Spatial Correction will be 1. However, guaranteeing the encoder pulse accuracy may not always be possible. In addition, lens magnification may not be exact—which will introduce a similar error.

The camera has a Line Spatial Correction feature that can correct for these small encoder or magnification errors on a sub-pixel level. The sub-pixel spatial correction resolution is 1/16th of a row. The feature accepts up to two decimal places and will adjust the entered sub-pixel adjustment component accordingly. This feature can only be adjusted when the acquisition is stopped.

Examples of artifacts generated by a small encoder error:

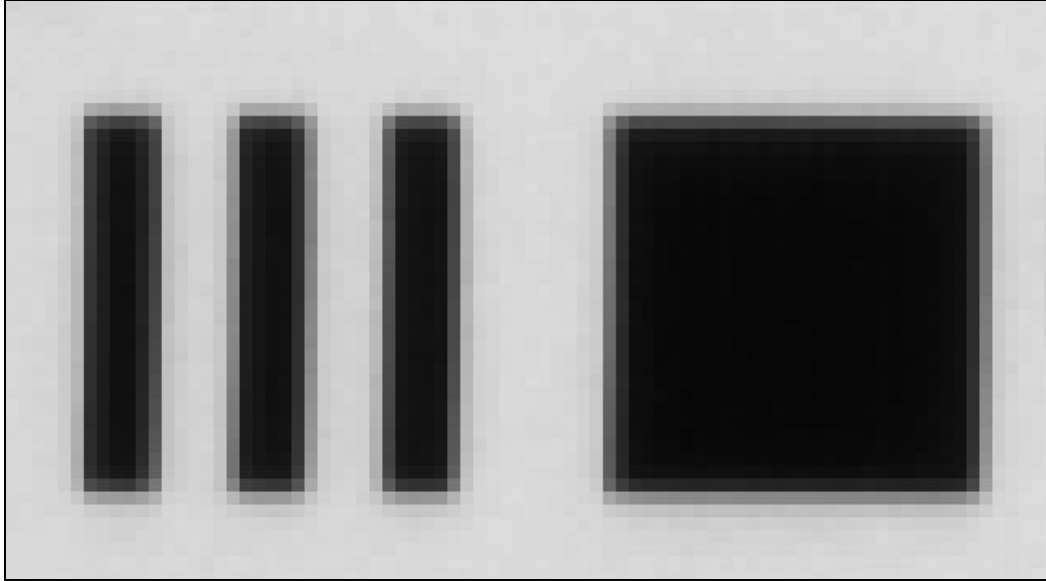

Object Pixel Setup for 20 μm , Encoder set at 19 μm . Forward Scanning
Can be corrected with $20 / 19 = 1.05$ Line Spatial Correction

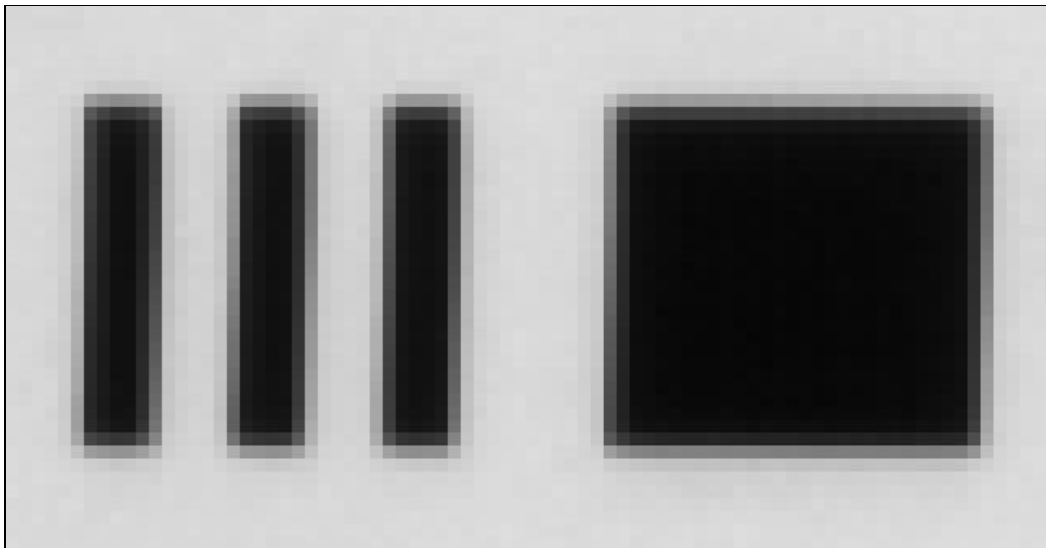

Object Pixel Setup for 20 μm , Encoder set at 21 μm . Forward Scanning
Can be corrected with $20 / 21 = 0.95$ Line Spatial Correction

If there are several different camera angles and associated illumination configurations in the inspection system, a single encoder pulse will not provide the correct timing for all the cameras.

For example, as the camera angle moves away from perpendicular, the image row spacing increases. If the encoder resolution remains at that for perpendicular operation, many encoder pulses will be too closely spaced, apparent row spacing will increase and the line spatial correction will need to change. The Line Spatial correction feature can accommodate these potentially larger encoder errors where the spatial correction value has an adjustment range from 0 to 1.5.

The following section details more aspects of using the camera at angles.

Parallax Correction: Using the Camera at Non-Perpendicular Angles to the Object

See Camera Control Category in Appendix A for GenICam features associated with this section and how to use them.

Related Features: [imageDistortionCorrectionMode](#), [imageDistortionCorrectionAlgorithm](#), [imageDistortionCorrectionLineSelector](#), [imageDistortionParallaxCorrectionPixelStretch](#)

When using a camera at an angle to the objects surface, the object pixel sizes for the three arrays are slightly different—this is due to parallax.

If the camera angle and the lens angular field of view are sufficiently large it may cause blurring at the extremities of the image in TDI mode. The camera includes a Parallax feature that can correct these artifacts.

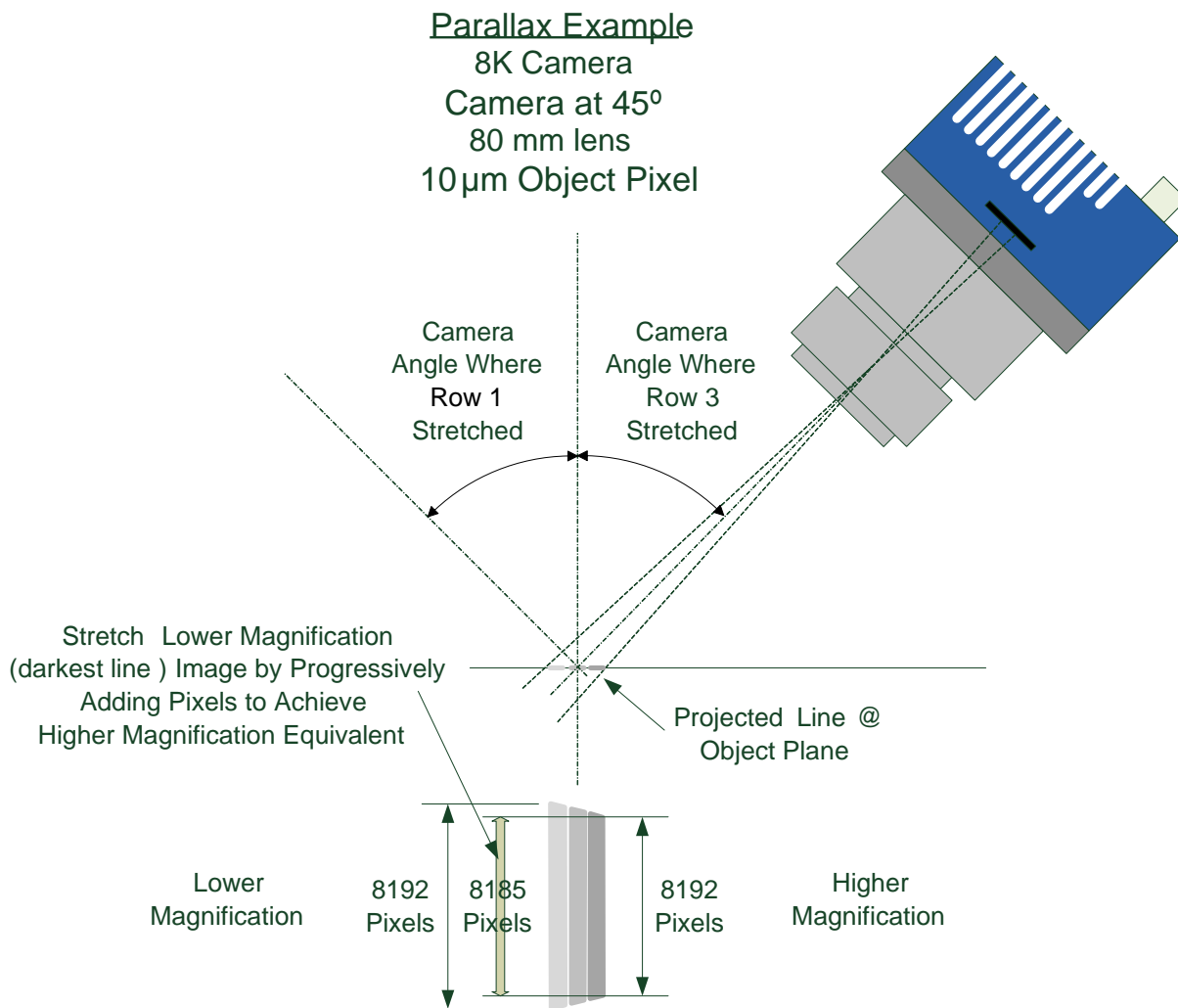

Figure 16. Camera Angle Creates Parallax

Notes:

- The selection of the line to adjust is dependent on positive or negative angle. It is not sensitive to scan direction.

Image example of artifact induced by parallax at the image extremity:



30° Camera Angle, 8k Camera, 80 mm lens, 20 μm Object Pixel,
Spatial Correction =9.2, No Parallax Correction

Establishing the Desired Response

One of the important performance characteristics of the camera that will determine its suitability for an application is its responsivity and the associated noise level at the system's maximum line rate and under the desired illumination conditions and lens configuration.

Responsivity and noise performance can be assessed using a stationary plain white target under bright field illumination or by using no target for rear bright field illumination.

To accurately evaluate the camera's responsivity and noise performance it is important that the camera setup is representative of the system configuration.

The ideal test setup meets the following conditions:

- The lens is in focus, at the desired magnification, and with the desired aperture.
- The illumination intensity is equal to that of the Automatic Optical Inspection (AOI) system and is aligned with the camera's field of view.
- The camera is operated with an exposure time that will allow the maximum line rate of the system to be achieved. The camera's internal line rate generator and exposure control can be used for a stationary target.

Exposure Mode

See the section *Camera Control Category in Appendix A for GenICam features associated with this section and how to use them.*

Related Features: [ExposureMode](#) (Timed, Sequential)

ExposureMode has 2 options: Timed and Sequential. Timed is the standard exposure operation as found in Teledyne DALSA line scan cameras. For operation of sequential mode, please see the section titled Exposure Mode Sequential. See the Exposure Control Section.

Line Rate Jitter

If the exposure time is close to the line period there could be jitter in the line rate when it is synchronized to the sensor clock if ExposureMode = Timed. With Exposure mode off or sequential there is no jitter in the line rate. If trying to coordinate a LED strobe with the exposure of the sensor it is important to be away of this jitter and make sure the LED is on long enough to account for this.

Exposure Control

See the *Camera Control Category section in Appendix A for GenICam features associated with this section and how to use them.*

Related features: [ExposureMode](#), [exposureTimeSelector](#), [exposureDelay](#), [ExposureTime](#)

The camera has two exposure modes:

- Timed: where the sensor rows are exposed at the same time.
- Sequential: where the sensor rows are exposed one after the other.

Use `exposureTimeSelector` to select whether to set the exposure time of each row independently or all to the same value. `exposureDelay` is only configurable when in Sequential exposure mode. Adjusting the exposure will result in a temporary loss of LVAL (8 lines) while the sensor is re-configured.

Timed Exposure Mode

Also called Global Reset Mode, the exposure begins when the line trigger occurs. If some rows have shorter exposure times then they are held in reset longer such that all the rows finish exposing at the same time and read out begins.

The minimum exposure time depends on the number of rows being read out. The maximum time is 1,500 μ s. The minimum line period is the largest exposure time + 0.83 μ s. With internal trigger mode the line rate will be decreased as necessary if the exposure time is increased. Similarly the exposure times will be decreased as necessary if the line rate is increased. If this happens the ratio between the different row exposure times will be maintained (e.g. to maintain white balance). In external trigger mode the maximum line rate will be limited by the current exposure time.

Sequential Exposure Mode

In this mode the rows are exposed in order: 0, 1, 2, 3. Use this for multi-spectral imaging using strobe illumination. In this mode the delay before the exposure can be configured for each row. The counters are smaller in this mode and so the maximum delay or exposure time is 45.48 μ s. Similar to timed mode, the sum of the delays and exposure times will limit the line rate.

Strobe lighting is synchronized using the General Purpose Outputs in the Digital IO Control category. Set the row with the `LineSelector` feature. Set the `outputLineSource` to On. And then set the `outputLinePulseDelay`, `outputLinePulseDuration`, and `LineInverter`.

Exposure Time Selector

See the section *Camera Control Category in Appendix A for GenICam features associated with this section and how to use them.*

Relevant Feature: [exposureTimeSelector](#)

The Exposure Time Selector allows the user to set the exposure time of each line individually or all to the same exposure time.



Note: If `TDIstagesSelector` is set to 2 or 3 all lines will automatically be set to the same exposure time.

Sequential Mode Application Example

The Linea ML is equipped with an innovative new mode that allows each line of the sensor to be exposed in a serial sequence with a single trigger applied to the camera. This can allow an object to be imaged with various lighting condition on a single pass of the image object past the camera. A typical camera/lighting setup is illustrated below in Figure 17. In this application the system consists of bright field, dark field and back lighting to allow imaging of the object. The camera has the ability to control the lighting in coordination with the exposure on each sensor line.

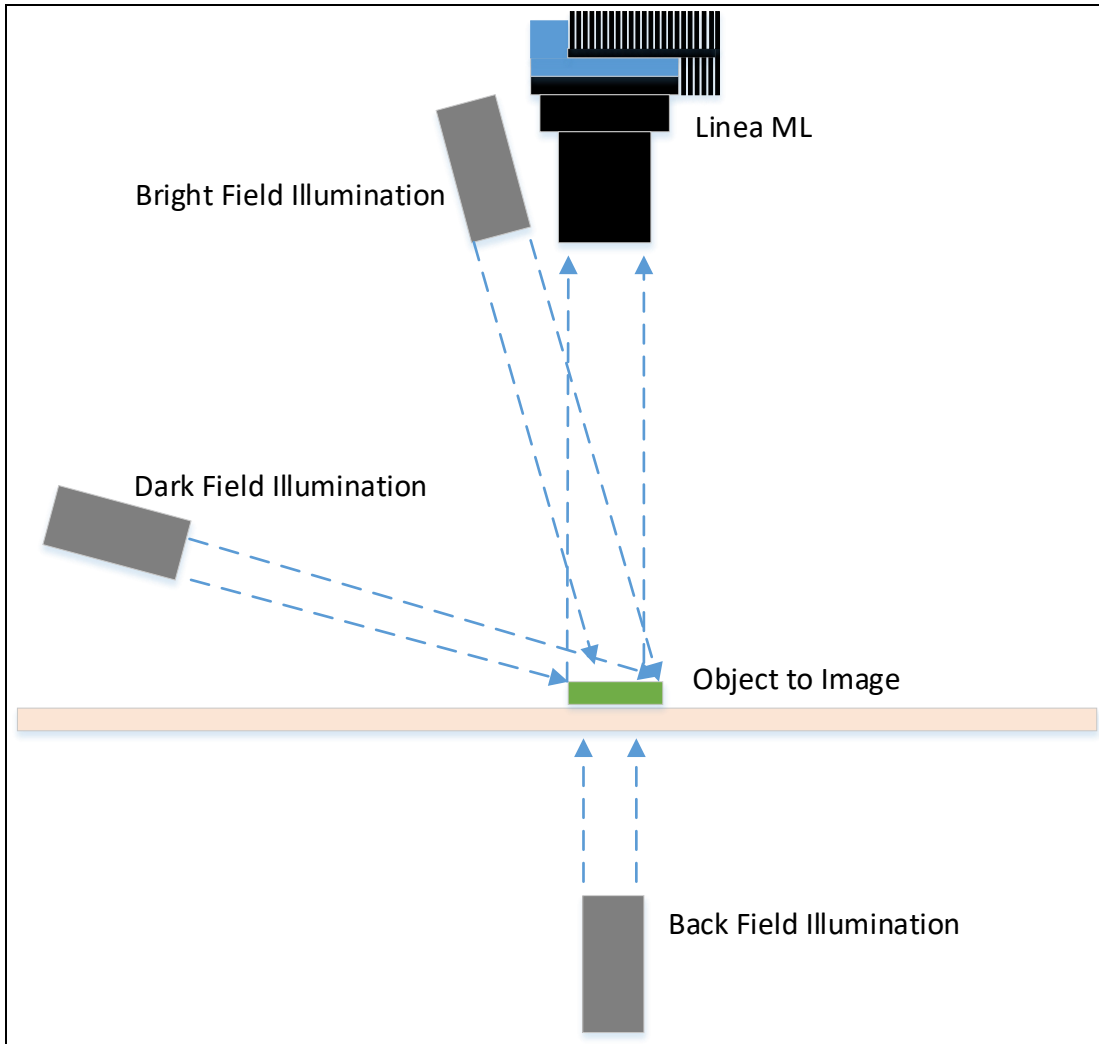

Figure 17. Typical Lighting Configuration

Exposure Mode Sequential

Relevant Features: [ExposureMode](#), [ExposureTime](#), [ExposureDelay](#), [TriggerDelay](#), [outputLinePulseDelay](#), [outputLinePulseDuration](#)

Unique to the Linea ML camera is the sequential exposure mode. For each trigger entering the camera the exposure for each line can be executed separately and in a serial sequence. This allows the user to set up different lighting conditions for each line. The figure below shows a typical time case for exposure mode sequential:

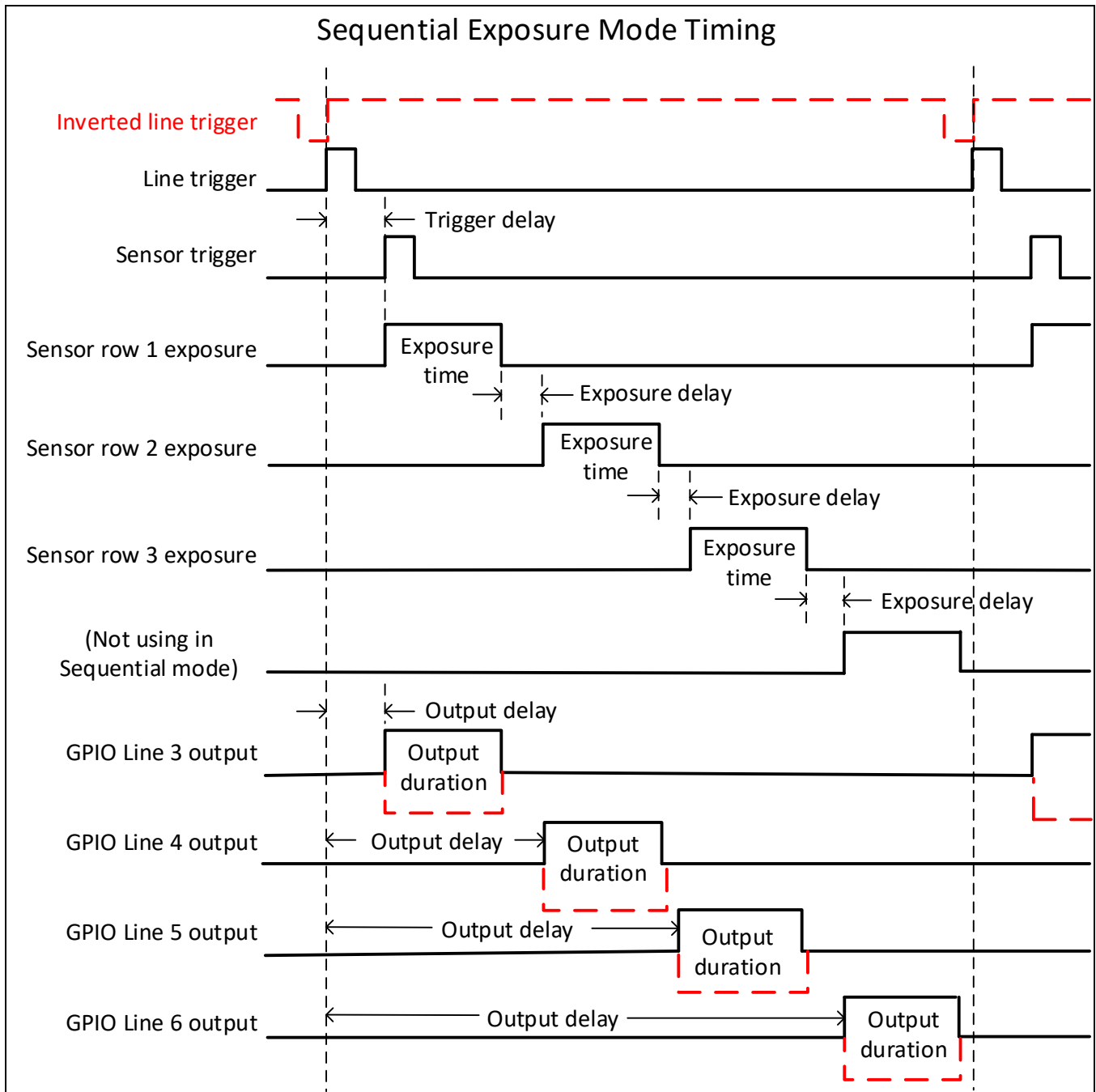



Figure 18 Typical Sequential Timing

The trigger signal entering the camera is routed to the sensor and also to each of the output control features.

The TriggerDelay feature delays the trigger going to the sensor. This delay allows the user to turn on the LED before exposing the sensor.

Each line can be delayed relative to the previous line using the ExposureDelay feature.



Note: The ExposureDelay feature can only be applied to the second, third or fourth lines being exposed.

The exposures for each line cannot overlap.

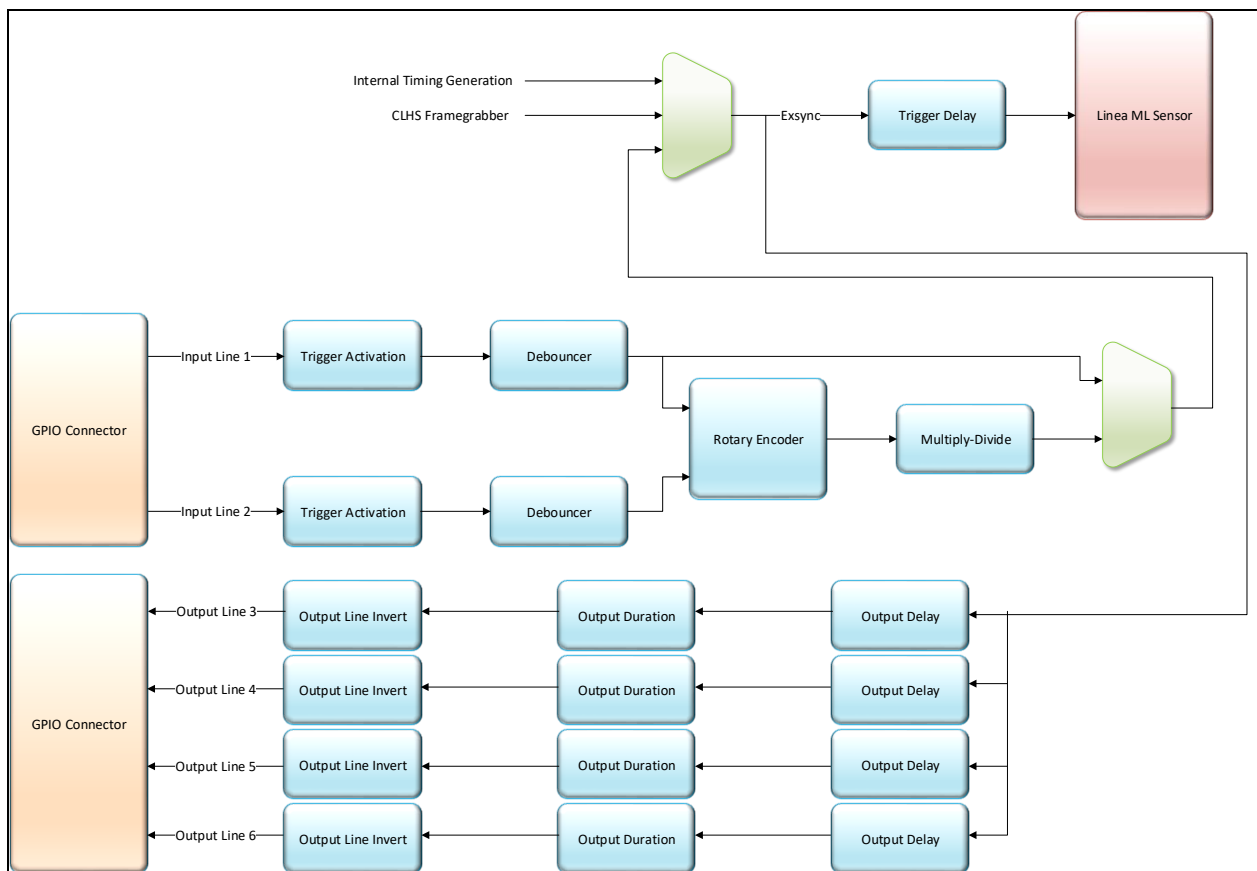

Figure 19. GPIO block diagram

The outputLinePulseDuration, outputLinePulseDelay, and LineInvert feature allow the user to control a light strobe source in order to coordinate with the sensor exposure.

Adjusting Responsivity

See the section *Camera Control Category* in Appendix A for GenICam features associated with this section and how to use them.

Relevant Features: [GainSelector](#), [Gain](#)

It is desirable for camera performance to always use the maximum exposure time possible based on the maximum line rate of the inspection system and any margin that may be required to accommodate illumination degradation. However, it will be necessary to adjust the responsivity to achieve the desired output from the camera. The camera has a gain feature that can be used to make the necessary adjustment to the responsivity.

There are two gain adjustments available: sensor row gains, which can be set independently for each sensor row; and the system gain, which is applied to all sensor rows.

Image Response Uniformity & Flat Field Calibration

See the section *Flat Field Category* in Appendix A for GenICam features associated with this section and how to use them

Related Features: [flatfieldCalibrationFPN](#), [flatfieldCalibrationPRNU](#), [flatfieldCorrectionAlgorithm](#), [Calibration Target](#)

It is common to find that an image has a lower response at the edges of the camera's field of view compared to its center. This is typically the result of a combination of lens vignetting ($\cos^{4\text{th}}$) roll-off and the beam structure of the illumination source. Using a more diffused light may reduce the roll-off effect. However, if decreasing the lens aperture improves the edge roll-off, then barrel vignetting (a shadow cast on the sensor by the focus helical or extension tubes) may also be present.

The camera can compensate for edge roll-off and other optical non-uniformities by using flat field calibration.

- When performing Flat Field (PRNU) calibration, the camera should be imaging a front illuminated white target or rear bright field illumination source. The optical setup should be as per the inspection system, including lens magnification, aperture, and illumination intensity, spectral content, plus illuminator beam structure.
- Flat field calibration should be performed when the camera temperature has stabilized.
- When the camera is asked to run a flat field calibration it will adjust all pixels to have the same value as that of the peak pixel value or target level, as per the calibration mode selected.
- If the flat field calibration is set to a target level that is lower than the peak value and the system gain is set to a low value, then it is possible that the sensor will maximize its output before the camera's output reaches 255 DN. This can be seen when a portion of the output stops increasing before reaching 255 DN with increasing illumination and the PRNU deteriorates. This effect can be resolved by decreasing the light level or exposure control time.

Following a flat field calibration, all pixels should be at their un-calibrated peak value or target value. Changing gain values now allows the user to make refinements to the operating responsivity level.

Note that the best flat field calibration can be achieved by performing it at the mid DN level of the working range used in the operation. Any flat field error associated with residual non-linearity in the pixel will be halved as compared to performing a calibration at the peak value of the operating range. A simple way of performing this is to reduce exposure time to half what is used in the operation in order to get the mid DN level for flat field calibration. Once complete, return the exposure time to its original setting.

Those areas of the image where high roll-off is present will show higher noise levels after flat field calibration due to the higher gain values of the correction coefficients. Flat field calibration can only compensate for up to an 8:1 variation. If the variation exceeds 8:1 then the line profile after calibration will include pixels that are below the un-calibrated peak level.



Note: The Linea ML camera has many different modes of operation. It is strongly recommended that the camera flat field be calibrated for the intended mode of operation.

Saving & Rapidly Loading a PRNU Set Only

Loading a complete user set takes approximately 800 ms while loading only the user PRNU coefficients takes less than 200 ms.

Use the User PRNU Set Selector parameter to select the set you want to save or load. 17 sets are available—16 user and 1 factory. Loading the Factory Set is a good way to clear the user PRNU.

The *Factory Set* is read-only. Loading the Factory Set is a good way to clear the user PRNU.

Save the current user PRNU coefficients using the “Save User PRNU Set” feature. Load the user PRNU coefficients from the set specified using the “User PRNU Set Selector” and the “Load User PRNU Set” command features.

Setting Custom Flat Field Coefficients

Flat Field (PRNU) coefficients can be custom modified and uploaded to the camera. They can also be downloaded from the camera.

To upload or download coefficients, use *File Access Control Category > Upload / Download File > Settings* and then select *Miscellaneous > Current PRNU* to download / upload a file.

The file format is described in the document 03-084-20133 Linea ML Binary File Format, which can be obtained from Teledyne DALSA Technical Support. This document also includes Excel spreadsheet examples.

The PRNU coefficients are used by the camera as soon as they are uploaded. To avoid loss at power up or while changing row settings, the uploaded coefficients should be saved to one of the available user sets.

Flat Field Calibration Filter

See the section *Flat Field Category* in Appendix A for GenICam features associated with this section and how to use them

Related Feature: [flatfieldCorrectionAlgorithm](#)

If a sheet of material is being used as a white target, it must be completely free of blemishes and texture.

The presence of dirt or texture will generate a variation in the image that will be incorporated into the calibration coefficients of the camera. Further, once the target is removed, or moved, vertical stripes will be present in the scanned image.

Dirt or texture that has dark characteristics will appear as bright vertical lines. Dirt or texture that has bright characteristics will appear as dark vertical lines.

One way to minimize this effect is to have the white target in motion during the calibration process. This has the result of averaging out any dirt or texture present. If this is not possible, the camera has a feature where a flat field calibration filter can be applied while generating the flat field correction coefficients—which can minimize the effects of dirt.



Note: This filter is only capable of compensating for small, occasional contaminants. It will not overcome large features in a target's texture. This filter is a 33 pixel moving average.

Flat Field Calibration Regions of Interest

See the section *Flat Field Category* in Appendix A for GenICam features associated with this section and how to use them

Related Features: [flatfieldROIOffsetX](#), [flatfieldROIWidth](#)

There are occasions when the camera's field of view includes areas that are beyond the material to be inspected.

This may occur when cameras image off the edge of a panel or web or when an inspection system is imaging multiple lanes of material. The edge of the material or area between lanes may not be illuminated in the same way as the areas of inspection and, therefore, will cause problems with a flat field calibration.

The camera can accommodate these "no inspection zones" by defining a Region of Interest (ROI) where flat field calibration is performed. Image data outside the ROI is ignored by the flat field calibration algorithm. The ROI is selected by the user and with the pixel boundaries defined by the pixel start address and pixel width and then followed by initiating flat field calibration for that region. Once set, the next ROI can be defined and flat field calibrated.

TDI Stage Selections and Full Well

See the section *Camera Control Category* in Appendix A for GenICam features associated with this section and how to use them

Relevant Features: [sensorTDIModeSelection](#), [sensorTDIStagesSelection](#), [sensorFullWellMode](#)

The camera's sensor has 3 high-responsivity lines. These line scans be summed to further increase the responsivity. The TDI Stage Selection feature with values of 1, 2, or 3 lines allows the user to increase the responsivity proportionally but at the sacrifice of the maximum line rate.

| Lines Summed / Averaged | Maximum Line Rate, 8 bit |
|-------------------------|--------------------------|
| 1 | 300 kHz |
| 2 | 150 kHz |
| 3 | 100 kHz |

Along with a reduction in line rate, other features need to be considered when using the stage selection feature. `SensorScanDirection` and `sensorLineSpatialCorrection` need to be set correctly if summing 2 or more lines using the TDI stage selection control. If only using one line, `sensorScanDirection` and `sensorLineSpatialCorrection` are not relevant.

`SensorTDIMode` allows the user to either sum the lines or average the lines. This allows the user to optimize the responsivity/full well or the signal to noise ratio.

If using 1 line only, there is the option of having high or low full well, using the `sensorFullWellMode`. There is a 4x difference in responsivity between these two modes and also a 4x difference in the full well.

HDR Demo Mode

In planar mode, the camera can be configured to output sensor row 0 and 1 separately. Under the same conditions, the row 1 is 4x more responsive than the row 0. The contrast ratio does not always have to be 4:1, it can be varied depending on the contrast of the object. The user can change the ratio by changing the exposure time and/or gain. Two different responsiveness give two different intensity images in a single scan. In conjunction with the user's algorithms, a High Dynamic Range (HDR) image can be created based on the two images. This merging process is called fusing. The goal of fusing is to replace all low contrast parts with the bright image accordingly and replace all saturated or near saturated parts with the dark image accordingly. Simple replacement, however, does not generate a seamless image, which we desire. In order to get an image which dark parts are enhanced, but no saturations occur, and which is fused seamlessly, an algorithm needs to be applied.

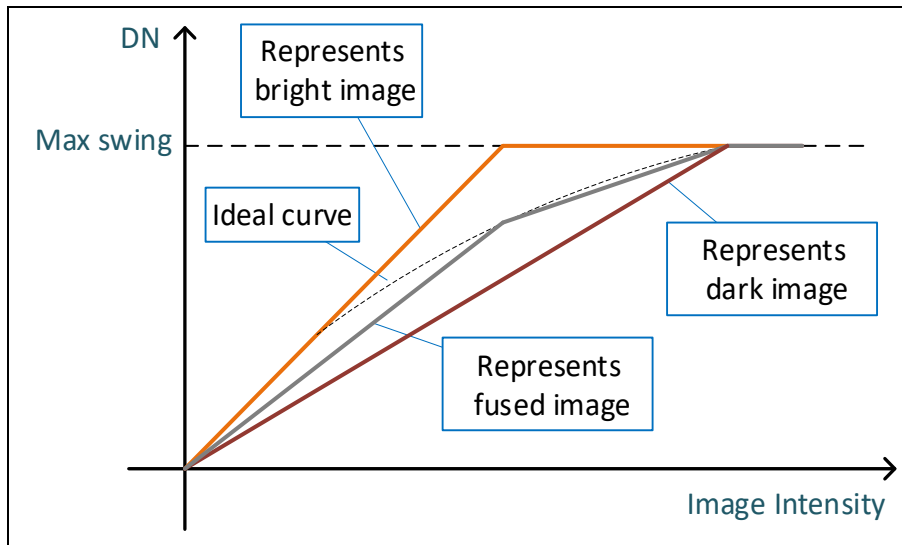

The HDR Demo mode demonstrates HDR imaging with a simple fusing algorithm, $y = ax + b(1-x)$, where $0 < x < 1$, a and b represent dark and bright images, respectively.

The gray curve in above graph represents this algorithm's result. The result is moderate, yet not perfect. The user can develop their own algorithm to better suit their applications' requirements. The following is a banknote example, which fused with $x=.5$ in above algorithm.



Binning

See the section *Image Format Control Category* in *Appendix A* for GenICam features associated with this section and how to use them

Related Features: Horizontal Binning, Vertical Binning

In certain applications, lower image resolution may be acceptable if the desired defect detection can still be achieved.

Binning is a process whereby adjacent pixels are summed. The camera supports 1x, 2x, and 4x binning in both horizontal and vertical directions.

Vertical Binning is achieved by the camera summing consecutive lines. Horizontal binning is achieved by summing adjacent pixels in the same line. 2x binning results in the object pixel doubling in size vertically, horizontally, or in both axes, as selected by the binning feature.

Vertical 2x binning will half the line rate output because two triggers are required read out the two lines to be summed. Horizontal 2x binning will halve the amount of image data out of the camera. This can be used to save processing bandwidth in the host and storage space by creating smaller image file sizes. In these cameras, since adjacent pixels are summed (not averaged) the image gets brighter. 1 x 2 and 2 x 1 are twice as bright, 2 x 2 is four times brighter.

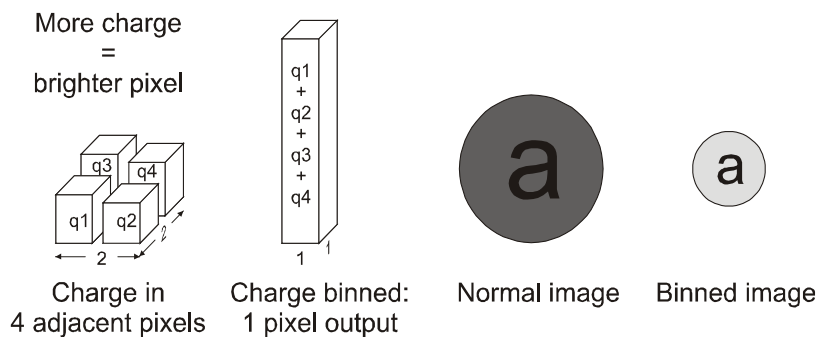

Figure 20. 2x2 Binning

For the camera, the default binning value is 1 x 1.



Note: Binning parameters can only be changed when image transfer to the frame grabber is stopped. Refer to the *Acquisition and Transfer Control Category* in the appendix for details on stopping and starting the acquisition.

Using Area of Interest to Reduce Image Data & Enhance Performance

See the section *Image Format Control Category* in *Appendix A* for GenICam features associated with this section and how to use them

Related Features: AOI Count, AOI Selector, AOI Offset, AOI Width

If the camera's field of view includes areas that are not needed for inspection (also refer to the description in the *Flat Field Calibration Region of Interest* section) then the user may want to ignore this superfluous image data.

Eliminating unwanted image data that is visible in the camera's field of view reduces the amount of information the host computer needs to process. This may result in an increase to the maximum allowable line rate when using 12-bit output data.

The camera can accommodate up to four AOIs. Image data outside the AOIs is discarded. Each AOI is user selected and its pixel boundaries defined. The camera assembles the individual AOI's into one contiguous image line with a width equal to the sum of the individual AOIs. The frame grabber will need to be adjusted to accommodate the smaller overall image width. As the host computer defined the size of each individual AOI's, it will be able to extract and process each individual AOI from the single larger image.

Steps to Setup Area of Interest

1. Plan your AOIs.
2. Stop acquisition.
3. Set the number of AOIs.
4. Select the first AOI and set the offset and width.
5. If the other AOIs are large then you may need to select them first and reduce their widths.
6. Repeat for each AOI in turn.
7. Start acquisition.

Rules for Setting Areas of Interest

The rules are dictated by how image data is organized for transmission over the available CLHS data lanes.

- The camera / XML will enforce these rules, truncating entered values where necessary.
1. Acquisition must be stopped to change the AOI configuration.
 2. 1-4 AOI's can be selected.
 3. Minimum width is 96 pixels per AOI.
 - a. Minimum total of all AOI widths summed together must be at least 1,024.
 4. Maximum width of all AOI widths summed together must be no more than = 16,384.
 - a. There can be maximum 8k bytes per CLHS lane.
 5. AOI width step size is 32 pixels.
 6. The offset of each AOI may be 0 to (16,384 - 96 = 16,288).
 - a. Therefore, overlapping AOI's are allowed.
 7. Offset and width for individual AOI's will "push" one another.
 - a. E.g. if AOI has offset 0, width 16,384, and the offset is changed to 4096, then the width will be "pushed" to 12,288.
 - b. AOI's only affect one another by limiting the maximum width.
 8. AOI's are concatenated together in numerical order and sent to the frame grabber starting at column zero.
 9. If the AOI count is reduced to less than the current AOI count, the AOI selector will be changed to the largest of the new AOI count available.

Customized Linearity Response (LUT)

See the section *Flat Field Category* in *Appendix A* for *GenICam* features associated with this section and how to use them

Related Features: lutMode, gammaCorrection



Note: These features may only be useful in applications that use the frame grabber's Mono Image Buffer Format. (See also the Pixel Format section.)

The Linea ML allows the user to access a LUT (Look-Up Table) to allow the user to customize the linearity of how the camera responds. This can be done by uploading a LUT to the camera using the file transfer features or by using the gammaCorrection feature.

The gamma correction value can be adjusted by the user at any time.

When the LUT is enabled, there is no change in maximum line rate or amount of data output from the camera. The LUT can be used with any mode of the camera. Further, when the LUT is enabled, it is recommended that the fixed Offset available in the Camera Control category be set to zero.

To upload a LUT, use *File Access Control Category > Upload / Download File > Settings* and select *Look Up Table* to upload a file.

The file format is described in 03-084-20133 Linea ML Binary File Format which can be obtained from Teledyne DALSA Technical Support. This document also includes Excel spread sheet examples.

How to Generate LUT with CamExpert

CamExpert can also be used to create a LUT file. The camera uses a 12-bit in / 12-bit out LUT (even if the camera is outputting an 8-bit image). CamExpert can be configured to create a 12-bit in / 16-bit out LUT - the camera will convert it to the required format.

1. Open CamExpert > version 8.40.
2. *Device* should be a *Xtium2* connected to a *Linea ML / HL* camera.
3. Under *Board* select *Basic Timing* and set *Pixel Depth* to 12.
4. Under *Board* select *Image Buffer and ROI* and set *Image Buffer Format* to *Monochrome 16 bits*
5. Leave *Image Buffer and ROI* selected.
6. In the top menu select *Pre-Processing | Lookup Table* and set *Enable*.
7. In the same menu select *Setting...*
8. Configure the output LUT here by scrolling through the different options under *Value*.
 - a. Some selections have additional parameters to configure (e.g. *Gamma correction* requires a *Correction factor*).
9. Click on the *Save LUT* button to create a LUT file.
10. This file can be loaded into the camera using the *File Access* features. It is saved with the current *Load / Save Configuration* user set; ensure that a user set and not the factory set is selected, otherwise the upload will fail.
11. Deselect the *Lookup Table | Enable* feature.
12. Return CamExpert to *Pixel Depth = 8*, and *Image Buffer = 8 bits*.

Important points:

- The frame grabber must be configured mono 12 bits in, 16 bits out.
- In the Parameters explorer a frame grabber feature must be selected, not a camera feature.
- The Lookup table must be enabled to be created. But should be disabled to use the camera LUT.

Adjusting Responsivity and Contrast Enhancement

See the section *Camera Control Category* in Appendix A for GenICam features associated with this section and how to use them.

Related Features: Gain Selector, Gain, Offset

It is best for camera performance to always use the maximum exposure time possible based on the maximum line rate of the inspection system and any margin that may be required to accommodate illumination degradation. However, it will be necessary to adjust the responsivity to achieve the desired output from the camera. The camera has a gain feature that can be used to adjust the camera's responsivity.

Gain adjustment is available to independently adjust each line or all of them together. System Gain can be adjusted from 1 to 10x. Individual line gains can be adjusted from 1 to 4x.

When an image contains no useful dark image data below a specific threshold, then it may be beneficial to increase the contrast of the image.

The camera has an offset feature that allows a specified level to be subtracted from the image data. The gain feature can then be used to return the peak image data to near output saturation with the result being increased image contrast.

First, determine the offset value you need to subtract from the image with the current gain setting you are using. Then set this as a negative offset value and apply additional gain to achieve the desired peak image data values.



Note: A positive offset value is not useful for contrast enhancement. However, it can be used while measuring the dark noise level of the camera to ensure zero clipping is not present.

Changing Output Configuration

Pixel Format

See the section *Image Format Control Category in Appendix A for GenICam features associated with this section and how to use them*

Related Feature: Pixel Format

The camera can output video data as 8-bit or 12-bit.

The Mono8 Pixel Format are selected when the user wants to process image data as one, two, or three separate image planes.



Note: The Pixel Format and associated features can only be changed when image transfer to the frame grabber is stopped. Refer to the Acquisition and Transfer Control Category in the appendix for details on stopping and starting acquisitions.

Using Two CLHS Cables

See the section *Image Format Control Category in Appendix A for GenICam features associated with this section and how to use them. ML-FM camera models support up to 2 fiber optic cables. ML-HM models only support 1 CX4 output connector.*

Relevant Features: Next CLHS Device Configuration

The ML-FM cameras have two CLHS compliant connectors. Control / Data1 is assigned as the master with Data 2 connector as the slave. Use the 'Next CLHS Device Configuration' to select the desired number of cables (not relevant for the 16K). This feature also controls lane selection. The Next CLHS Device Configuration becomes active after power cycling the camera or reconnecting the cables.

Saving & Restoring Camera Setup Configurations

See the section *Camera Information Category* in *Appendix A* for GenICam features associated with this section and how to use them

Related Features: Power-up Configuration Selector, UserSet1 thru UserSet16, User Set Selector, Power-on User Set, Current User Set

An inspection system may use multiple illumination, resolution, and responsivity configurations in order to cover the different types of inspection it performs.

The camera includes 16 user sets where camera setup information can be saved to and restored from—either at power up, or dynamically during inspection.

The settings active during the current operation can be saved using the user set selector and user set save features.

A previously saved user setting (User Set 1 to 16) or the factory settings can be restored using the user set selector and user set load features.

Either the factory setting or one of the user settings can be configured as the default setting, by selecting the set in the user set default selector. The set selected is the set that is loaded and becomes active when the camera is reset or powered up.

The relationship between the settings is illustrated in Figure 21. Relationship between the Camera Settings:

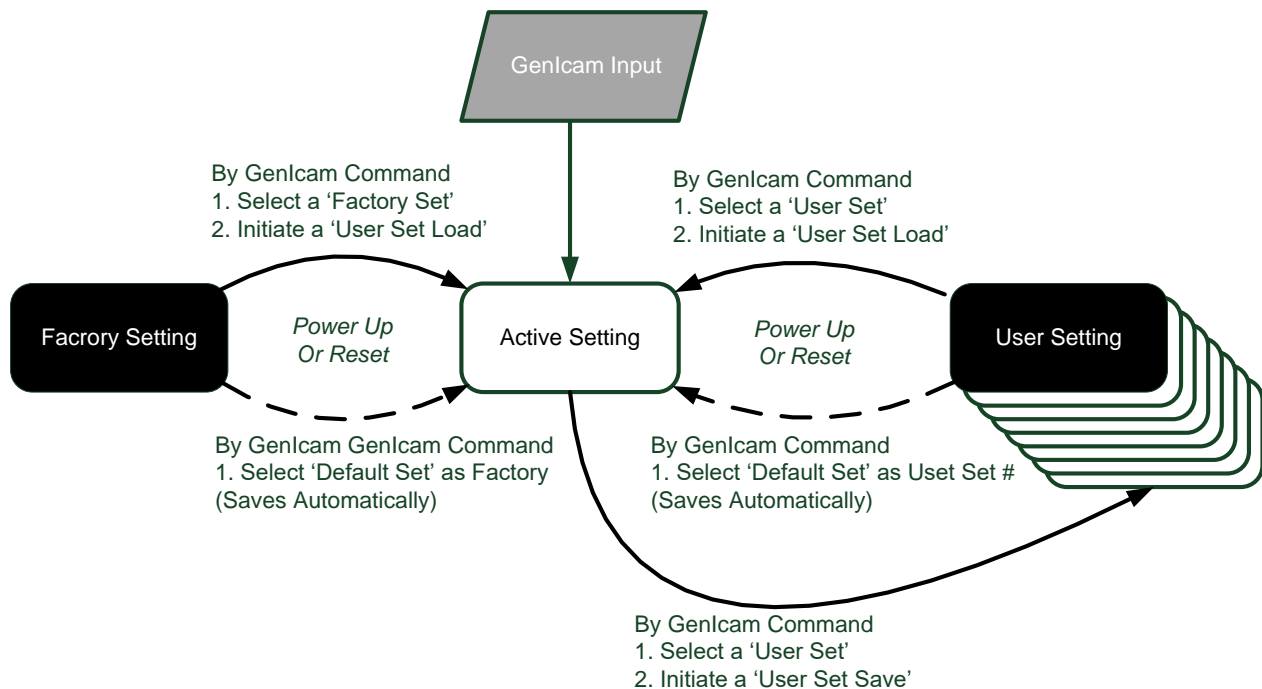

Figure 21. Relationship between the Camera Settings

Active Settings for Current Operation

Active settings are those settings used while the camera is running and include all unsaved changes made by GenICam input to the settings.

These active settings are stored in the camera's *volatile* memory and will be lost and cannot be restored if the camera resets, is powered down, or loses power during operation.

To save these settings so that they can be restored next time you power up the camera, or to protect against losing them in the case of power loss, you must save the current settings using the user set save parameter. Once saved, the current settings become the selected user set.

User Setting

The user setting is the saved set of camera configurations that you can customize, resave, and restore. By default, the user settings are shipped with the same settings as the factory set.

The command user set save saves the current settings to non-volatile memory as a user set. The camera automatically restores the user set configured as the default set when it powers up.

To restore a saved user set, set the user set selector to the set you want to restore and then select the user set load parameter.

Factory Settings

The factory setting is the camera settings that were shipped with the camera and which loaded during the camera's first power-up. To load or restore the original factory settings, at any time, select the factory setting parameter and then select the user set load parameter.



Note: By default, the user settings are set to the factory settings.

Default Setting

The default setting is the set loaded when the camera is powered up. Either the factory or one of the user settings can be used as the default setting by selecting the set to use in the user set default selector. The chosen set automatically becomes the default setting and is the set loaded when the camera is reset or powered up.

Appendix A: GenICam Commands

This appendix lists the available GenICam camera features. The user may access these features using the CamExpert interface or equivalent GUI.

Features listed in the description table but tagged as *Invisible* are typically reserved for Teledyne DALSA Support or third-party software usage, and not typically required by end user applications.

The following feature tables describe these parameters along with their view attributes and in which version of the device the feature was introduced. Additionally the Standard column will indicate which parameter is a member of the DALSA Features Naming Convention (using the tag **DFNC**), versus the GenICam Standard Features Naming Convention (SFNC tag not shown).

In the CamExpert Panes, parameters in gray are read only, either always or due to another parameter being disabled. Parameters in black are user set in CamExpert or programmable via an imaging application



Note: CamExpert examples are shown for illustrative purposes and may not entirely reflect the features and parameters available from the camera model used in your application.

Camera Information Category

Camera information can be retrieved via a controlling application. Parameters such as camera model, firmware version, etc. are read to uniquely identify the connected camera. These features are typically read-only.

The Camera Information Category groups information specific to the individual camera. In this category the number of features shown is identical whether the view is Beginner, Expert or Guru.

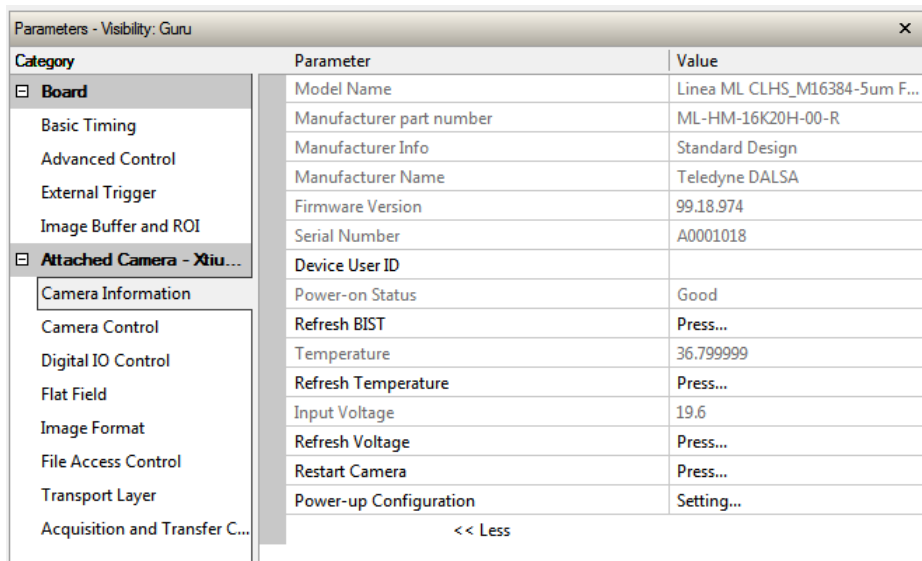

Figure 22: CamExpert Camera Information Category

Camera Information Feature Descriptions

| Display Name | Feature | Description | Standard & View |
|---------------------------------|------------------------------|--|-----------------|
| Model Name | DeviceModelName | Displays the device model name. (RO) | Beginner |
| Vendor Name | DeviceVendorName | Displays the device vendor name. (RO) | Beginner |
| Part Number | deviceManufacturesPartNumber | Displays the device vendor part number. (RO) | Beginner |
| Standard | DeviceVersion | Displays the Standard. Highlights if the firmware is a beta or custom design. Updates when firmware upgraded. (RO) | Beginner |
| Manufacturer Info | DeviceManufacturerInfo | This feature provides extended manufacturer information about the device. E.g. Whether product is standard or custom. (RO) | Beginner |
| Serial Number | DeviceSerialNumber | Displays the device's factory set camera serial number. Same as the camera label. (RO) | Beginner |
| Device User ID | DeviceUserID | Feature to store user-programmable identifier of up to 31 characters. The default factory setting is the camera serial number. (RW) | Beginner |
| Power-up Configuration Selector | UserSetDefaultSelector | Selects the camera configuration set (Factory, UserSet 1 – 16) to load and make active on camera power-up or reset. The camera configuration sets are stored in camera non-volatile memory. (RW) | Beginner |

| Display Name | Feature | Description | Standard & View |
|---------------------------|------------------------|--|------------------|
| Load & Save Configuration | UserSetSelector | Selects the camera configuration set (Factory, UserSet 1 – 16) to load feature settings from or save current feature settings to. The Factory set contains default camera feature settings. (RW) | Beginner |
| Power-on User Set | UserSetDefaultSelector | Allows the user to select between the factory set and 1 to 16 user sets to be loaded at power up | Beginner |
| Current User Set | UserSetSelector | Points to which user set (1-16) or factory set that is loaded or saved when the UserSetLoad or UserSetSave command is used. | Beginner |
| Load Configuration | UserSetLoad | Loads the camera configuration set specified by the User Set Selector feature, to the camera and makes it active. (W) | Beginner |
| Save Configuration | UserSetSave | Saves the current camera configuration to the user set specified by the User Set Selector feature. The user sets are located on the camera in non-volatile memory. (W) | Beginner |
| Power-on Status | deviceBISTStatus | Determine the status of the device using the 'Built-In Self-Test' (BIST). Possible return values are listed in Appendix B. (RO) | DFNC Beginner |
| Temperature | deviceTemperature | Displays the internal operating temperature of the camera. (RO) | DFNC Beginner |
| Refresh Temperature | refreshTemperature | Press to display the current internal operating temperature of the camera. | DFNC Beginner |
| Input Voltage | deviceInputVoltage | Displays the input voltage to the camera at the power connector (RO) | DFNC Beginner |
| Refresh Voltage | refreshVoltage | Press to display the current input voltage of the camera at the power connector | DFNC Beginner |
| Restart Camera | DeviceReset | Used to restart the camera (Warm restart) | Beginner |
| Device Reset | DeviceReset | Press to reset or reboot the camera | DFNC Beginner |

Built-In Self-Test Codes (BIST)

In the Camera Information screen shot example above, the Power-On Status is showing the 23 status flags where '1' is signaling an issue. When there are no issues, the Power-On status will indicate "Good".

Details of the BIST codes can be found in [Appendix B: Troubleshooting Guide](#).

Camera Power-Up Configuration Selection Dialog

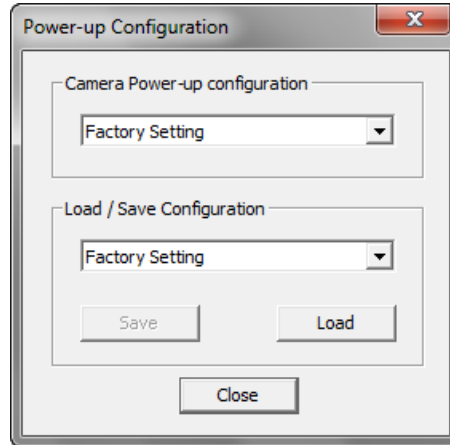

CamExpert provides a dialog box which combines the menu option used to select the camera's power-up state and the options for the user to save or load a camera state as a specific user set that is retained in the camera's non-volatile memory.

Camera Power-up Configuration

The first drop list selects the camera configuration state to load on power-up (see feature *UserSetDefaultSelector*). The user chooses from the factory data set or from one of 16 available user-saved states.

User Set Configuration Management

The second drop list allows the user to change the camera configuration any time after a power-up (see feature *UserSetSelector*). To reset the camera to the factory configuration, select *Factory Set* and click Load. To save a current camera configuration, select User Set 1 to 16 and click Save. Select a saved user set and click Load to restore a saved configuration.

Camera Control Category

The camera control category, as shown by CamExpert, groups control parameters such as line rate, exposure time, scan direction and gain.

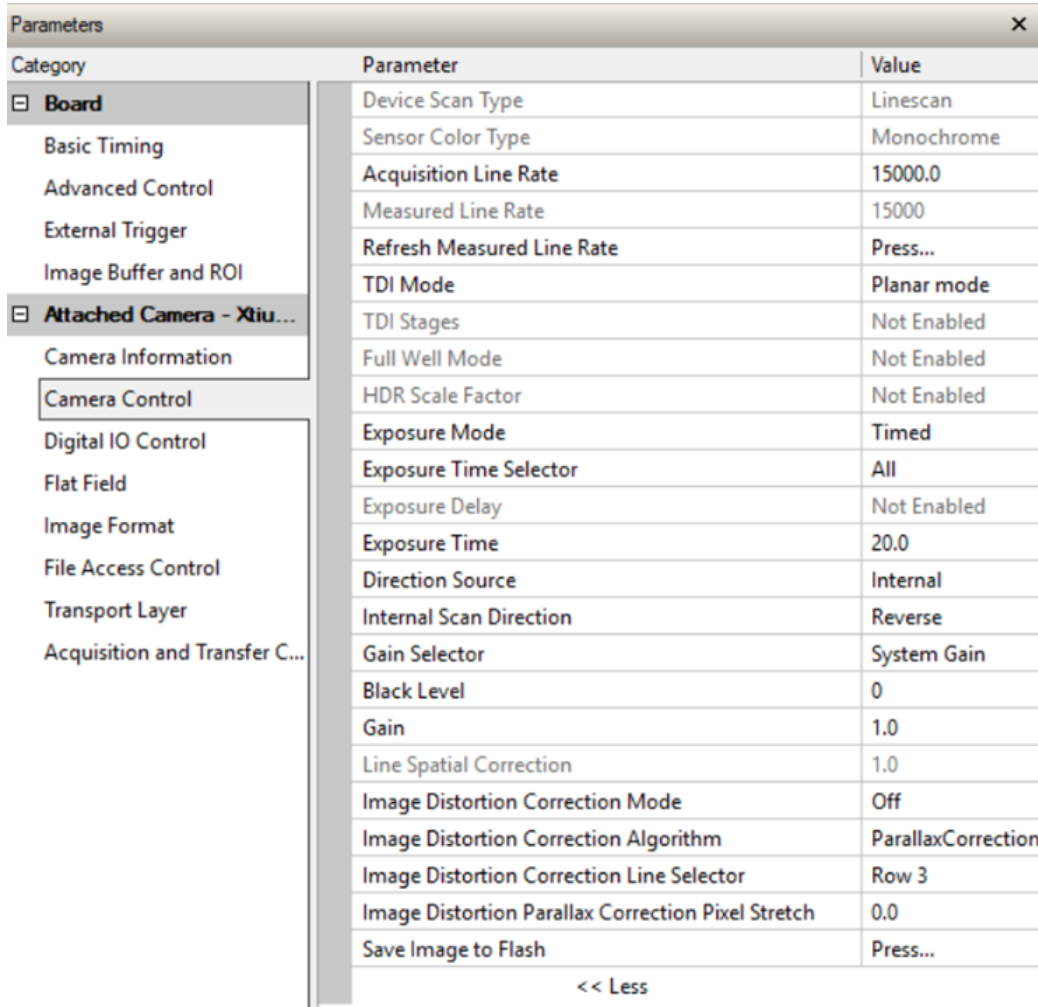

| Category | Parameter | Value |
|--|----------------------------|-------------|
| Board | Device Scan Type | Linescan |
| | Sensor Color Type | Monochrome |
| | Acquisition Line Rate | 15000.0 |
| | Measured Line Rate | 15000 |
| | Refresh Measured Line Rate | Press... |
| | TDI Mode | Planar mode |
| | TDI Stages | Not Enabled |
| | Full Well Mode | Not Enabled |
| | HDR Scale Factor | Not Enabled |
| | Exposure Mode | Timed |
| | Exposure Time Selector | All |
| | Exposure Delay | Not Enabled |
| | Exposure Time | 20.0 |
| | Direction Source | Internal |
| Internal Scan Direction | Reverse | |
| Gain Selector | System Gain | |
| Black Level | 0 | |
| Gain | 1.0 | |
| Line Spatial Correction | 1.0 | |
| Image Distortion Correction Mode | Off | |
| Image Distortion Correction Algorithm | ParallaxCorrection | |
| Image Distortion Correction Line Selector | Row 3 | |
| Image Distortion Parallax Correction Pixel Stretch | 0.0 | |
| Save Image to Flash | Press... | |

<< Less

Figure 23: CamExpert Camera Control Category

Camera Control Feature Descriptions

| Display Name | Feature | Description | Standard & View |
|--|--|---|------------------|
| Device Scan Type <i>Linescan</i> | DeviceScanType <i>Linescan</i> | Used to set the camera scanning mode. Only standard line scan mode is available. (RO) <i>Linescan sensor.</i> | Beginner |
| Sensor Color Type | sensorColorType | Identifies the sensor color type "Monochrome." (RO) | Beginner |
| Acquisition Line Rate | AcquisitionLineRate | Specifies the camera internal line rate, in Hz when Trigger mode set to internal. | Beginner |
| Measured Line Rate | measuredLineRate | Specifies the line rate provided to the camera by either internal or external source (RO) | Beginner DFNC |
| Refresh Measured Line Rate | refreshMeasuredLineRate | Press to update measuredLineRate. | Beginner DFNC |
| TDI Mode <i>Planar Mode</i> <i>Summed</i> <i>Average</i> <i>HDR Demo</i> | sensorTDIModeSelection <i>TdiOff</i> <i>TdiSum</i> <i>TdiAvg</i> <i>TdiHdr</i> | Used to select the camera mode of operation <i>Each row enabled is output starting with low CCE (charge conversion efficiency).</i> <i>Rows summed together (starting with second sensor row).</i> <i>Rows averaged (starting with second sensor row).</i> <i>Combines high and low full well sensor rows to produce a single High Dynamic Range row.</i> | Beginner DFNC |
| TDI Stages <i>1</i> <i>2</i> <i>3</i> | sensorTDIStagesSelection <i>Lines1</i> <i>Lines2</i> <i>Lines3</i> | Used to determine the number of rows to be summed or averaged. Not enabled when in planar or HDR modes. In planar mode the lines to output are configured using the component features in the Image Format category. HDR is fixed to the bottom two lines. <i>Single line.</i> <i>Two lines summed/averaged together.</i> <i>Three lines summed/averaged together.</i> | Beginner DFNC |
| Full Well Mode <i>Low</i> <i>High</i> | sensorFullWellMode <i>Low</i> <i>High</i> | Selects between low and high full well sensor row when TDI Stages is one. Low full well is four times more responsive. <i>Low full well row.</i> <i>High full well row.</i> | Beginner DFNC |

| Display Name | Feature | Description | Standard & View |
|---|--|--|------------------|
| Line Spatial Correction | sensorLineSpatialCorrection | Sets the number of rows each line is delayed to establish spatial alignment. Must stop acquisition to change. | Beginner DFNC |
| Image Distortion Correction Mode <i>Off</i> <i>Active</i> | imageDistortionCorrectionMode <i>Off</i> <i>Active</i> | Used to enable parallax correction. | Expert DFNC |
| Image Distortion Correction Algorithm <i>ParallaxCorrection</i> | imageDistortionCorrectionAlgorithm <i>ParallaxCorrection</i> | Read only. Indicates the type of correction algorithm used, for example, Parallax. | Expert DFNC |
| Image Distortion Correction Line Selector <i>Row 1</i> <i>Row 3</i> | imageDistortionCorrectionLineSelector <i>Row1</i> <i>Row 3</i> | Used to select which line will be stretched to correct the image | Expert DFNC |
| Image Distortion Parallax Correction Pixel Stretch | imageDistortionParallaxCorrectionPixelStretch | The stretch value in pixels at the ends of line one or three. Note the stretch value for line two is always half that of the stretch value regardless of which line is selected. | Expert DFNC |
| Save Image To Flash | saveLastImageToFlash | Captures the current line and saves it to the cameras Flash memory as a TIFF file that can be retrieved using the File Access Control Features | Guru |

Digital I / O Control Category

The Digital I / O Control features are used to configure the camera's GPIO pins.

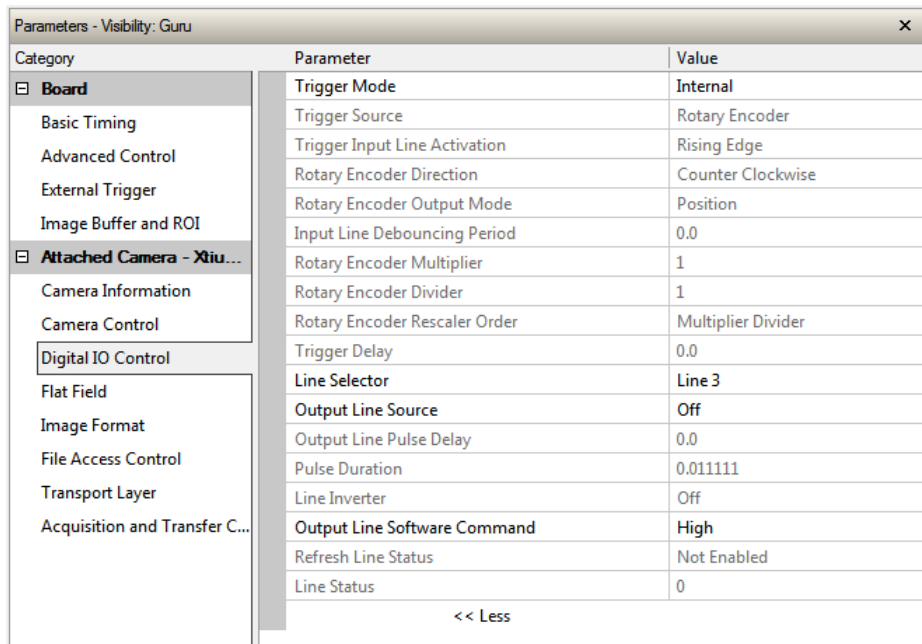

Figure 24: CamExpert Digital I/O Control Category

Digital I/O Control Feature Descriptions

| Display Name | Feature | Description | Standard & View |
|-----------------------------------|--|--|------------------|
| Trigger Mode | TriggerMode <i>Internal</i> <i>External</i> | Determines the source of trigger to the camera, internal or external | DFNC Beginner |
| Trigger Source | TriggerSource <i>CLHS In</i> <i>Rotary Encoder</i> <i>GPIO1</i> | Determines the source of external trigger <i>Source of trigger is from the frame grabber.</i> <i>Source of trigger is from the two shaft encoder inputs.</i> <i>Source of trigger is from Line 1 of the GPIO connector.</i> | DFNC Beginner |
| Trigger Input Line ActivationEdge | TriggerActivation <i>RisingEdge</i> <i>FallingEdge</i> <i>AnyEdge</i> | Determines which edge of a input trigger will activate on. The two inputs are XOR'd together when Shaft Encoder is selected to provide a single signal. <i>The trigger is considered valid on the rising edge of the line source signal (after any processing by the line inverter module).</i> <i>The trigger is considered valid on the falling edge of the line source signal.</i> <i>The trigger is considered valid on any edge.</i> | DFNC Beginner |

| Display Name | Feature | Description | Standard & View |
|---|--|--|------------------|
| Rotary Encoder Direction <i>Counter Clockwise</i> <i>Clockwise</i> | rotaryEncoderDirection <i>CounterClockwise</i> <i>Clockwise</i> | Specifies the phase which defines the encoder forward direction. <i>Inspection goes forward when the rotary encoder direction is counter clockwise (phase A is ahead of phase B).</i> <i>Inspection goes forward when the rotary encoder direction is clockwise (phase B is ahead of phase A).</i> | DFNC Beginner |
| Rotary Encoder Output Mode | rotaryEncoderOutputMode <i>Position</i> <i>Motion</i> | Specifies the conditions for the Rotary Encoder interface to generate a valid Encoder output signal. <i>Triggers are generated at all new position increments in the selected direction. If the encoder reverses no trigger events are generated until it has again passed the position where the reversal started.</i> <i>The triggers are generated for all motion increments in either direction.</i> | DFNC Beginner |
| Input Line Debouncing Period | lineDebouncingPeriod | Specifies the minimum delay before an input line voltage transition is recognizing as a signal transition. | DFNC Beginner |
| Rotary Encoder Multiplier | rotaryEncoderMultiplier | Specifies a multiplication factor for the rotary encoder output pulse generator. | DFNC Beginner |
| Rotary Encoder Divisor | rotaryEncoderDivider | Specifies a division factor for the rotary encoder output pulse generator. | DFNC Beginner |
| Rotary Encoder Rescaler Order <i>Multiplier Divider</i> <i>Divider Multiplier</i> | rotaryEncoderRescalerOrder <i>multiplierDivider</i> <i>dividerMultiplier</i> | Specifies the order that the multiplier and divider are applied. <i>The signal is multiplied before been divided.</i> <i>The signal is divided before been multiplied.</i> | DFNC Beginner |
| Trigger Delay | TriggerDelay | Allows the trigger to the sensor to be delayed relative to camera input trigger | DFNC Beginner |
| Line Selector <i>Line 1</i> <i>Line 2</i> <i>Line 3</i> <i>Line 4</i> <i>Line 5</i> <i>Line 6</i> | LineSelector <i>GPIO 1</i> <i>GPIO 2</i> <i>GPIO 3</i> <i>GPIO 4</i> <i>GPIO 5</i> <i>GPIO 6</i> | Selects the physical line (or pin) of the external device connector to configure. <i>External trigger or rotary encoder A.</i> <i>External direction or rotary encoder B.</i> <i>Output 1.</i> <i>Output 2.</i> <i>Output 3.</i> <i>Output 4.</i> | DFNC Beginner |
| Output Line Source <i>On</i> <i>Off</i> | outputLineSource <i>On</i> <i>Off</i> | Selects which internal signal to output on the selected line. <i>Current output line is set with outputLineSoftwareCmd</i> <i>Current output line is configured with outputLinePulseDelay, outputLinePulseDuration, and LineInverter.</i> | DFNC Beginner |
| Output Line Pulse Delay | outputLinePulseDelay | Sets the delay (in μ s) before the output line pulse signal. Applicable for the OutputLineSource feature. | DFNC Beginner |

| Display Name | Feature | Description | Standard & View |
|---|--|---|--------------------------------------|
| Output Line Pulse Duration | outputLinePulseDuration | Sets the width (duration) of the output line pulse in microseconds. | DFNC Beginner |
| Line Inverter <i>On</i> <i>Off</i> | LineInverter <i>On</i> <i>Off</i> | Controls whether to invert the polarity of the selected input or output line signal. | DFNC Beginner |
| Output Line Software Command <i>Low</i> <i>High</i> | outputLineSoftwareCmd <i>Low</i> <i>High</i> | Set the GPIO out value when outputLineSource is off. | DFNC Expert |
| Refresh Line Status Line Status <i>Low</i> <i>High</i> | refreshLineStatus LineStatus <i>Low</i> <i>High</i> | Command CamExpert to update LineStatus Returns the current status of the line selected with LineSelector. (RO) | DFNC Expert DFNC Expert |

Flat Field Category

The Flat Field controls, as shown by CamExpert, group parameters used to control the FPN and PRNU calibration process.

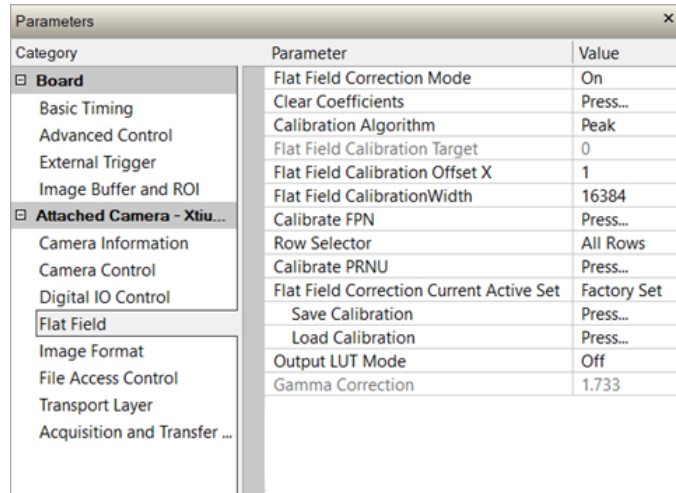

Figure 25: CamExpert Flat Field Category

Flat Field Control Feature Descriptions

| Display Name | Feature | Description | Standard & View |
|----------------------------|--------------------------------------|--|------------------|
| Flat Field Correction Mode | flatfieldCorrectionMode | <i>Off</i> FPN and PRNU correction disabled. <i>On</i> FPN and PRNU correction enabled. | Beginner DFNC |
| Clear Coefficients | flatfieldCalibrationClearCoefficient | Reset all FPN to 0 and all PRNU coefficients to 1. | |

| Display Name | Feature | Description | Standard & View |
|---|---|--|------------------|
| Output LUT Mode <i>Off</i> <i>Gamma Correction</i> <i>User Defined</i> | lutMode <i>Off</i> <i>Gamma Correction</i> <i>User Defined</i> | Allows the output LUT to be selected <i>The output LUT is disabled and linear data is output</i> <i>The output LUT is populated using the gamma correction equation.</i> <i>LUT uploaded by the user is used.</i> | Beginner DFNC |
| Gamma Correction | gammaCorrection | The output LUT is populated using the following gamma correction equation: $DN_{out} = 255 \times \left(\frac{DN_{in}}{255}\right)^{\frac{1}{\gamma}}$ | Beginner DFNC |

Image Format Control Category

The camera's Image Format controls, as shown by CamExpert, group parameters used to configure camera pixel format, image cropping, binning and test pattern generation features.

| Category | Parameter | Value | |
|----------------------|---------------------------|-------------------|-------|
| Board | Pixel Format | Mono 8 | |
| | Pixel Size | 8 Bits/Pixel | |
| | Pixel Coding Filter | None | |
| | Line Select | Line 1 | |
| | Line Enable | True | |
| | Line row ID | 1 | |
| | Attached Camera - Xtiu... | Sensor Width | 16384 |
| | | Horizontal Offset | 0 |
| | | Output Width | 16384 |
| | | Height | 4 |
| Binning Horizontal | | 1 | |
| Binning Vertical | | 1 | |
| Test Pattern | | Off | |
| AOI Count Horizontal | | 1 | |
| AOI Selector | 1 | | |
| AOI Offset | 0 | | |
| AOI Width | 16384 | | |

Figure 26: CamExpert Image Format Category

Image Format Control Feature Description

| Display Name | Feature | Description | Standard & View |
|---|--|---|------------------|
| Pixel Format <i>Mono8</i> <i>Mono12</i> | PixelFormat <i>Mono8</i> <i>Mono12</i> | Output image pixel coding format of the sensor. | Beginner |
| Pixel Size | PixelFormat | Number of bits per pixel (RO) | |
| Pixel Color Filter | PixelFormat | Always "None" for mono camera (RO) | Beginner DFNC |
| Line Select | ComponentSelect | Select line (0-3) to enable when in planar mode. | |
| Line Enable <i>False</i> <i>True</i> | ComponentEnable <i>False</i> <i>True</i> | Enable/disables the selected line. Available only in planar mode. | Beginner DFNC |
| Sensor Width | WidthMax | Indicates the maximum number of pixels available in the long (line) axis the sensor. Read only | Beginner DFNC |
| Horizontal Offset | OffsetX | Output image horizontal offset from the origin. This is always zero. Read only | Beginner DFNC |
| Output Width | Width | Horizontal width of the out pixels. Equals the sum of AOI's. Read only | Beginner DFNC |
| Height | Height | Height of the image provided by the device (in <u>object</u> pixels) [1-4] Read only. | Beginner DFNC |

| | | | |
|---|--|--|-------------------|
| Binning Vertical | BinningVertical | Number of vertically adjacent pixels to sum together. This increases the intensity of the pixels and reduces the vertical resolution of the image [1, 2, 4] | Beginner |
| Binning Horizontal | BinningHorizontal | Number of horizontally adjacent pixels to sum together. This increases the intensity of the pixels and reduces the horizontal resolution of the image [1, 2, 4] | Beginner |
| Test Pattern <i>Off</i> <i>Each Tap Fixed</i> <i>Grey Horizontal Ramp</i> <i>Grey Vertical Ramp</i> <i>Grey Diagonal Ramp</i> <i>User Pattern</i> | TestImageSelector <i>Off</i> <i>EachTapFixed</i> <i>GreyHorizontalRamp</i> <i>GreyVertica Ramp</i> <i>GreyDiagonalRamp</i> <i>UserTp</i> | Selects the type of test image that is sent by the camera. <i>Selects sensor video to be output from sensor</i> <i>Selects a grey scale value that is increased every 512 pixels.</i> <i>Selects a grey scale ramp.</i> <i>Selects a grey scale ramp progressively for each row.</i> <i>Selects a combination of horizontal and vertical raps to form a diagonal grey scale.</i> <i>User can define a test pattern by uploading to the camera a PRNU file using the FileAccess > Miscellaneous > User PRNU feature. The PRNU coefficient will be applied to a midscale (128DN) test image.</i> | Beginner DFNC |
| AOI Count | multipleROICount | Specified the number of AOI's in an acquired image, 1 to 4 | Beginner |
| AOI Selector | multipleROISelector | Select 1 of up to 4 AOI's when setting the AOI Offset & AOI Width | Beginner |
| AOI Offset | multipleROIOffsetX | Location of the start of a single Area of Interest to be output, must be a multiple of 32. | Beginner |
| AOI Width | multipleROIWidth | Width of the start of a single Area of Interest to be output. Minimum is 96 per lane. e.g., if there is only one AOI spread across the 5 lanes then the minimum is 5 x 96 = 480. Maximum of the sum of AOI width's is the sensor width. e.g., for a 16k sensor, if there are two AOI's with the first 12k wide, then the second can be no wider than 4k. | Beginner |
| Input Pixel Size <i>12 Bits/Pixel</i> | pixelSizeInput <i>Bpp12</i> | Size of the image input pixels, in bits per pixel. (RO) <i>Sensor input data path is 12</i> | DFNC Invisible |

Transport Layer Control Category

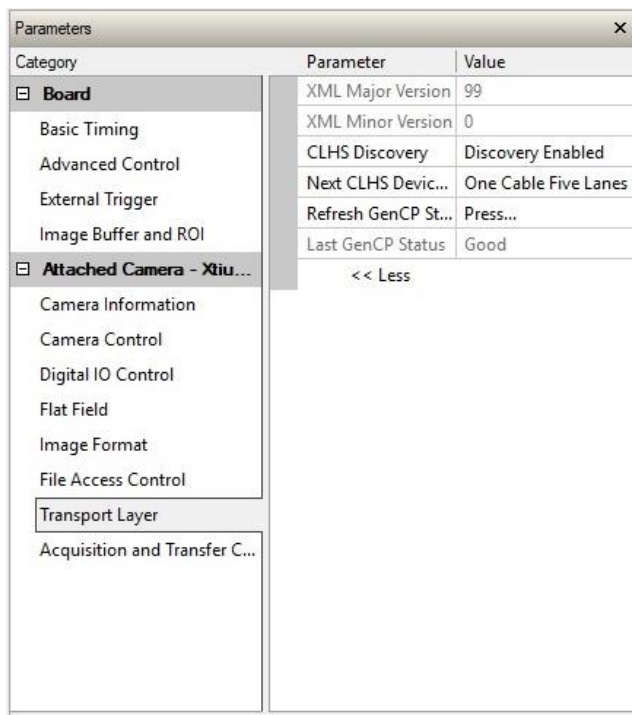

Figure 27: CamExpert Transport Layer Category

Transport Layer Feature Descriptions

| Display Name | Feature | Description | Standard & View |
|----------------------|-------------------------------|--|------------------|
| XML Major Version | DeviceManifestXMLMajorVersion | Together with DeviceManifestXMLMinorVersion specifies the GenICam™ feature description XML file version. (RO) | Beginner DFNC |
| XML Minor Version | DeviceManifestXMLMinorVersion | Together with DeviceManifestXMLMajorVersion specifies the GenICam™ feature description XML file version. (RO) | Beginner DFNC |
| Refresh GenCP Status | refreshGenCPStatus | Press to update the GenCP Status | Beginner |
| Last GenCP Status | genCPStatus | Returns the last error. If a feature read or write fails then Sapera only returns that it fails – read this feature to get the actual reason for the failure Reading this feature clears it. | Beginner DFNC |

| | | | |
|--------------------------------|--------------------------|--|--------------|
| CLHS Discovery | clhsDiscovery | Selects whether the camera needs to be commanded to send image data after power up. | Guru DFNC |
| <i>Discovery Disabled</i> | <i>DiscoverDisable</i> | <i>POGO (Power On & GO mode) – as soon as the camera detects a cable it enables its transmitters and starts sending image data.</i> | |
| <i>Discovery Enabled</i> | <i>DiscoveryEnable</i> | <i>Camera waits for LL_Device_ID to be set before enabling its transmitters. User must then read XML and all features and then send an Acquisition Start before the camera will send image data.</i> | |
| Next CLHS Device Configuration | clhsNext DeviceConfig | When the camera is next powered up, the specified CLHS lane configuration will be set for the camera. | Guru DFNC |
| <i>One cable five lanes</i> | <i>OneCableFiveLanes</i> | | |
| <i>One cable one lane</i> | <i>OneCableOneLane</i> | | |
| <i>Two cable one lane</i> | <i>TwoCablesOneLane</i> | | |

Acquisition and Transfer Control Category

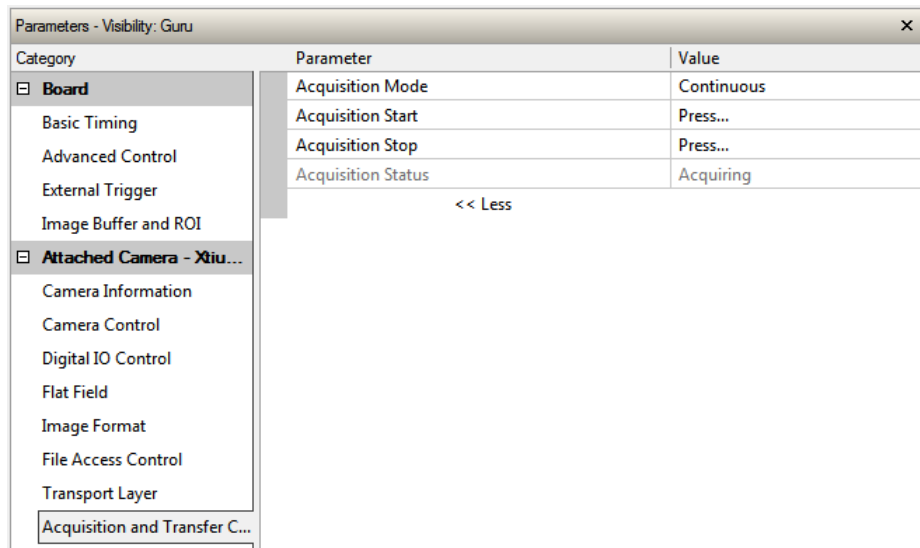

Figure 28: Cam Expert Acquisition & Transfer Control Category

Acquisition and Transfer Control Feature Descriptions

| Display Name | Feature | Description | Standard & View |
|---------------------------------------|-------------------|---|------------------|
| Acquisition Mode <i>Continuous</i> | AcquisitionMode | The device acquisition mode defines the number of frames to capture during an acquisition and the way it stops. Only continuous mode is currently available | Beginner DFNC |
| Acquisition Start | AcquisitionStart | Commands the camera to start sending image data. (WO) | Beginner DFNC |
| Acquisition Stop | AcquisitionStop | Commands the camera to stop sending image data at the end of the current line (WO) | Beginner DFNC |
| Acquisition Status | AcquisitionStatus | Indicates whether the camera has been commanded to stop or to send image data. | Beginner DFNC |

File Access Control Category

The File Access control in CamExpert allows the user to quickly upload and download various data files to/from the connected the camera. The supported data files for the camera include firmware updates and Flat Field coefficients.



Note: Communication performance when reading and writing large files can be improved by stopping image acquisition during the transfer.

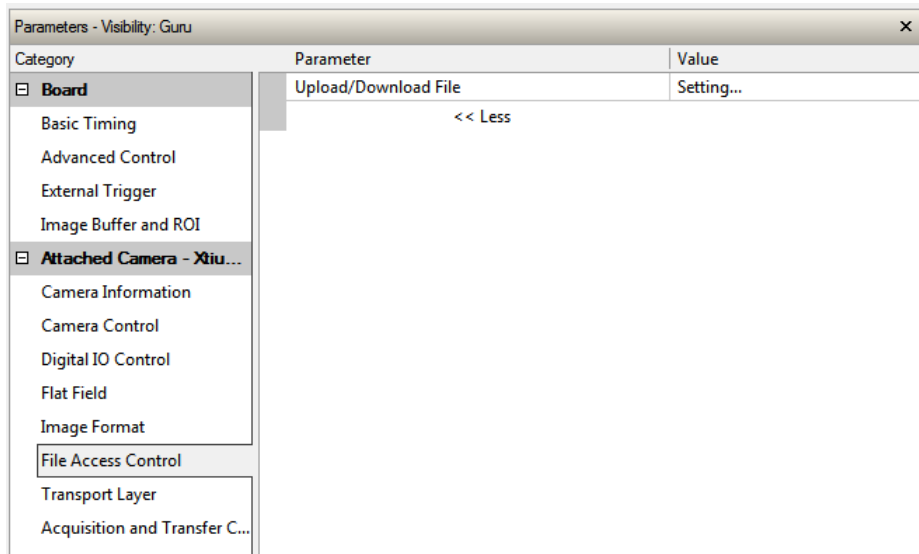

Figure 29: CamExpert File Access Control Category

File Access Control Feature Descriptions

| Display Name | Feature | Description | Standard & View |
|-----------------|--------------|---|-----------------|
| File Selector | FileSelector | Selects the file to access. The files which are accessible are listed in the XML. | Beginner DFNC |
| Device Firmware | Firmware1 | Upload micro code, FPGA code & XML as a single file to the camera which will execute on the next camera reboot cycle. | |
| User Set | User_Set | Use UserSetSelector to specify which user set to access. | |
| Look-up Table | Output_LUT | Use UserSetSelector to specify which LUT to access. | |
| User PRNU | User_PRNU | Use UserSetSelector to specify which user PRNU to access. | |
| User FPN | User_FPN | Use UserSetSelector to specify which user FPN to access. | |
| Current PRNU | Cur_PRNU | Accesses the PRNU coefficients that are currently being used by the camera (not necessarily saved). | |
| CameraData | CameraData | Download camera information and send for customer support. | |

File Access via the CamExpert Tool

1. Click on the "Setting..." button to show the file Access Control dialog box.

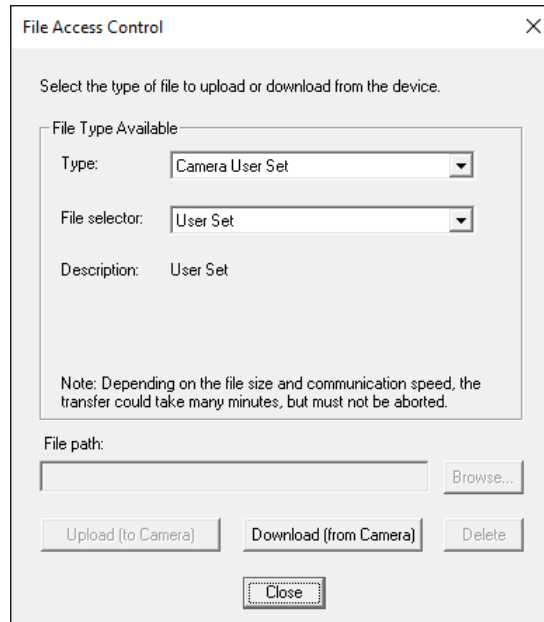

Figure 30: File Access Control Tool

2. From the Type drop menu, select the file type that will be uploaded to the camera or downloaded from the camera.
3. From the File Selector drop menu, select the file to be uploaded or downloaded.
4. To upload a file, click the Browse button to open a typical Windows Explorer window.
 - a. Select the specific file from the system drive or from a network location.
 - b. Click the Upload button to execute the file transfer to the camera.
5. Alternatively, click the Download button and then specify the location where the file should be stored.
6. Note that firmware changes require that the camera be powered down and then back up. Additionally, CamExpert should be shut down and restarted following a reset.
7. Caution: Do not interrupt the file transfer by powering down the camera or closing CamExpert.

CLHS File Transfer Protocol

If you are not using CamExpert to perform file transfers, pseudo-code for the CLHS File Transfer Protocol is as follows.

Upload File

1. Select the file by setting the FileSelector feature
2. Set the FileOpenMode to Read
3. Set the FileOperationSelector to Open
4. Open the file by setting FileOperationExecute to 1. This is a read-write feature - poll it every 100 ms until it returns 0 to indicate it has completed
5. Read FileOperationStatus to confirm that the file opened correctly
A return value of 0 is success. Error codes are listed in the XML.
6. Read FileSize to get the number of bytes in the file
7. From FileAccessBuffer.Length you will know that maximum number of bytes that can be read through FileAccessBuffer is 988.
8. For Offset = 0 While ((Offset < FileSize) and (Status = 0)) Do
 - a. Set FileAccessOffset to Offset
 - b. Set FileAccessLength to min(FileSize - Offset, FileAccessBuffer.Length), the number of bytes to read
 - c. Set the FileOperationSelector to Read
 - d. Read the file by setting FileOperationExecute to 1 and poll until 0 and complete
 - e. Read FileOperationStatus to confirm the read worked
 - f. Read FileOperationResult to confirm the number of bytes read
 - g. Read the bytes from FileAccessBuffer
 - h. Write bytes read to host file.
9. Next Offset = Offset + number of bytes read
10. Set the FileOperationSelector to Close
11. Close the file by setting FileOperationExecute to 1 and poll until 0 and complete
12. Read FileOperationStatus to confirm the close worked

Download File

1. Select the file by setting the FileSelector feature
2. Set the FileOpenMode to Write
3. Set the FileOperationSelector to Open
4. Open the file by setting FileOperationExecute to 1. This is a read-write feature - poll it every 100 ms until it returns 0 to indicate it has completed
5. Read FileOperationStatus to confirm that the file opened correctly. A return value of 0 is success. Error codes are listed in the XML.
6. Read FileSize to get the maximum number of bytes allowed in the file
7. Abort and jump to Close if this is less the file size on the host
8. From FileAccessBuffer.Length you will know that maximum number of bytes that can be written through FileAccessBuffer is 988.
9. For Offset = 0 While ((Offset < Host File Size) and (Status = 0)) Do
 - a. Set FileAccessOffset to Offset
 - b. Set FileAccessLength to min(Host File Size - Offset, FileAccessBuffer.Length), the number of bytes to write
 - c. Read next FileAccessLength bytes from host file.
 - d. Write the bytes to FileAccessBuffer
 - e. Set the FileOperationSelector to Write
 - f. Write to the file by setting FileOperationExecute to 1 and poll until 0 and complete
 - g. Read FileOperationStatus to confirm the write worked
 - h. Read FileOperationResult to confirm the number of bytes written
10. Next Offset = Offset + number of bytes written
11. Set the FileOperationSelector to Close
12. Close the file by setting FileOperationExecute to 1 and poll until 0 and complete
13. Read FileOperationStatus to confirm the close worked

Download a List of Camera Parameters

For diagnostic purposes you may want to download a list of all the parameters and values associated with the camera.

1. Go to File Access Control
2. Click on Settings
3. In the "Type" drop down box select "Miscellaneous."
4. In the "File selector" drop down box select "CameraData."
5. Hit "Download"
6. Save the text file and send the file to Teledyne DALSA customer support.

Appendix B: Troubleshooting Guide

Diagnostic Tools

Camera Data File

The camera data file includes the operational configuration and status of the camera.

This text file can be downloaded from the camera and forwarded to Teledyne DALSA Technical Customer support team to aid in diagnosis of any reported issues. See Saving & Restoring Camera Setup Configurations of the user manual for details on downloading the Camera Data file.

Voltage & Temperature Measurement

The camera can measure the input supply voltage at the power connector and the internal temperature. Both of these features are accessed using the Camera CamExpertGUI > Camera Information tab. Press the associated refresh button for a real-time measurement.

Test Patterns – What Can They Indicate?

The camera can generate fixed test patterns that may be used to determine the integrity of the CLHS communications beyond the Lock status. The test patterns give the user the ability to detect bit errors using an appropriate host application. This error detection would be difficult, if not impossible, using normal image data.



Note: Grey images are displayed so that any bit error will immediately be apparent as colored pixels in the image.

There are five test patterns that can be selected via the Cameras CamExpertGUI > Image Format tab. They have the following format when using 8-bit data:

- Each Tap Fixed
 - Starting at 64 increases in by 4 steps every 512 pixels ending in 188.
- Grey Horizontal Ramp
 - 2 horizontal ramps starting at 0 increases in by 1 every 32 pixels.
- Grey Vertical Ramp
- Grey Diagonal Ramp
 - Add horizontal and vertical ramps.
- User Pattern
 - When selected, the camera will first output all pixel values to be half full scale. The user can then generate a custom test pattern by uploading PRNU coefficients that appropriately manipulate the half scale data to achieve the desired pattern. See section Setting Custom Flat Field Coefficients for details.

Built-In Self-Test Codes

The Built-In Self-test (BIST) codes are located in the Camera Information pane under Power-on Status. None of these should occur in a properly functioning camera except OVER_TEMPERATURE. OVER_TEMPERATURE occurs if the ambient temperature is too high, or if there is insufficient air circulation or heat sinking.

| Bit Number | Name | Hex Position | Binary Translation |
|------------|---------------------|--------------|---|
| 1 | I2C | 0x00000001 | 0000 0000 0000 0000 0000 0000 0000 0001 |
| 2 | FPGA_NO_INIT | 0x00000002 | 0000 0000 0000 0000 0000 0000 0000 0010 |
| 3 | FPGA_NO_DONE | 0x00000004 | 0000 0000 0000 0000 0000 0000 0000 0100 |
| 4 | SENSOR SPI | 0x00000008 | 0000 0000 0000 0000 0000 0000 0000 1000 |
| 5 | ECHO_BACK | 0x00000010 | 0000 0000 0000 0000 0000 0000 0001 0000 |
| 6 | FLASH_TIMEOUT | 0x00000020 | 0000 0000 0000 0000 0000 0000 0010 0000 |
| 7 | FLASH_ERROR | 0x00000040 | 0000 0000 0000 0000 0000 0000 0100 0000 |
| 8 | NO_FPGA_CODE | 0x00000080 | 0000 0000 0000 0000 0000 0000 1000 0000 |
| 9 | NO_COMMON_SETTINGS | 0x00000100 | 0000 0000 0000 0000 0000 0001 0000 0000 |
| 10 | NO_FACTORY_SETTINGS | 0x00000200 | 0000 0000 0000 0000 0000 0010 0000 0000 |
| 11 | OVER_TEMPERATURE | 0x00000400 | 0000 0000 0000 0000 0000 0100 0000 0000 |
| 12 | SENSOR PATTERN | 0x00000800 | 0000 0000 0000 0000 0000 1000 0000 0000 |
| 13 | NO_USER_FPN | 0x00001000 | 0000 0000 0000 0000 0001 0000 0000 0000 |
| 14 | NO_USER_PRNU | 0x00002000 | 0000 0000 0000 0000 0010 0000 0000 0000 |
| 15 | CLHS_TXRDY_RETRY | 0x00004000 | 0000 0000 0000 0000 0100 0000 0000 0000 |
| 16 | (Reserved) | 0x00008000 | 0000 0000 0000 0000 1000 0000 0000 0000 |
| 17 | NO_USER_SETTINGS | 0x00010000 | 0000 0000 0000 0001 0000 0000 0000 0000 |
| 18 | NO_ADC_COEFFICIENTS | 0x00020000 | 0000 0000 0000 0010 0000 0000 0000 0000 |
| 19 | NO_SCRIPT | 0x00040000 | 0000 0000 0000 0100 0000 0000 0000 0000 |
| 20 | (Reserved) | 0x00080000 | 0000 0000 0000 1000 0000 0000 0000 0000 |
| 21 | (Reserved) | 0x00100000 | 0000 0000 0001 0000 0000 0000 0000 0000 |
| 22 | (Reserved) | 0x00200000 | 0000 0000 0010 0000 0000 0000 0000 0000 |
| 23 | NO_FACT_PRNU | 0x00400000 | 0000 0000 0100 0000 0000 0000 0000 0000 |
| 24 | NO_FATFS | 0x00800000 | 0000 0000 1000 0000 0000 0000 0000 0000 |

Status LED

A single red / green LED is located on the back of the camera to indicate status.

| LED State | Description |
|-----------------|---|
| Off | Camera not power up or waiting for the software to start |
| Constant Red | The camera BIST status is not good. See BIST status for diagnosis. |
| Blinking Red | The camera has stopped output and has shut down some components due to an over temperature condition. |
| Blinking Orange | Powering Up. The microprocessor is loading code. |
| Blinking Green | Hardware is good, but the CLHS connection has not been established or has been broken. |
| Constant Green | The CLHS Link has been established and data transfer may begin |

Resolving Camera Issues

Communications:

No Camera Features when Starting CamExpert

If the camera's CamExpert GUI is opened and no features are listed, then the camera may be experiencing lane lock issues.

While using the frame grabber CamExpert GUI you should be able to see a row of status indicators below the image area that indicates the status of the CLHS communications. These indicators include seven lane lock status and a line valid (LVAL) status.

If the status for one or more lane locks is red, then there is likely an issue with the CLHS connectors at the camera and / or frame grabber. Ensure that the connectors are fully engaged and that the jack screws are tightened. Ensure that you are also using the recommended cables.

No LVAL

If the LVAL status is red and all lane locks are green, then there may be an issue with the camera receiving the encoder pulses.

1. From the Camera CamExpert > Digital I / O Control tab, select Internal Trigger Mode and set the CamExpert > Camera Control tab Acquisition Line Rate to the maximum that will be used.
2. The trigger signal from the frame grabber will not be used and the LVAL status should now be green. This will confirm the integrity of the image data portion of the CLHS cabling and connectors.
3. From the Camera CamExpert > Digital I / O Control tab, select External Trigger Mode.
4. From the Frame Grabber CamExpert > Advanced tab, select the Line Sync Source to be Internal Line Trigger and the Internal Line Trigger frequency to the maximum that will be used.
5. The trigger source is now being generated by the frame grabber and the LVAL status should be green. This will confirm the integrity of the General Purpose I / O portion of the CLHS cabling and connectors.
6. From the Frame Grabber CamExpert > Advanced tab, select the Line Sync Source to be External Line Trigger and select the Line Trigger Method to Method 2 under the same tab.
7. From the Frame Grabber CamExpert > External Trigger tab, select External Trigger to be enabled. If LVAL status turns red, check the following:
 - a. Is the transport system moving such that encoder pulses are being generated?
 - b. Has the encoder signal been connected to the correct pins of the I/O connector of the frame grabber? See the XTIUM-CLHS frame grabber user manual for details.
 - c. Do the encoder signal levels conform to the requirements outlined in the XTIUM-CLHS frame grabber user manual?

Image Quality Issues

Vertical Lines Appear in Image after Calibration

The purpose of flat field calibration is to compensate for the lens edge roll-off and imperfections in the illumination profiles by creating a uniform response. When performing a flat field calibration, the camera must be imaging a flat white target that is illuminated by the actual lighting used in the application. Though the camera compensates for illumination imperfection, it will also compensate for imperfections such as dust, scratches, paper grain, etc. in the white reference. Once the white reference is removed and the camera images the material to be inspected, any white reference imperfections will appear as vertical stripes in the image. If the white reference had imperfections that caused dark features, there will be a bright vertical line during normal imaging. Similarly, bright features will cause dark lines. It can be very difficult to achieve a perfectly uniform, defect-free white reference. The following two approaches can help in minimizing the effects of white reference defects:

1. Move the white reference closer to or further away from the object plane such that it is out of focus. This can be effective if the illumination profile changes minimally when relocating the white reference.
2. If the white reference must be located at the object plane, then move the white reference in the scan direction or sideways when flat field calibration is being performed. The camera averages several thousand lines when capturing calibration reference images so any small imperfections are averaged out.
3. Use the cameras flat field calibration filter feature, as detailed in the user manual Flat Field Calibration Filter section. This algorithm implements a low pass moving average that covers several adjacent pixels. This filter can help minimize the effects of minor imperfections in the white reference.



Note: This filter is NOT USED in normal imaging.

Over Time, Pixels Developing Low Response

When flat field calibration is performed using a white reference, as per the guidelines in the user manual, all pixels should achieve the same response. However, over time dust in the lens extension tube may migrate to the sensor surface and reduce the response of some pixels.

If the dust particles are small, they may have only a minor effect on responsivity, but still create vertical dark lines that interfere with defect detection and that need to be corrected.

Because repeating the flat field calibration with a white reference may not be practical while the camera installed in the system, the camera has a feature where the flat field coefficients can be downloaded to the host PC and adjusted using a suitable application, such as Microsoft Excel. (See section Setting Custom Flat Field Coefficients for details.)

If the location of the pixel returning a low response can be identified from the image, then the correction coefficient of that pixel can be adjusted, saved as a new file, and then uploaded to the camera; thereby correcting the image without performing a flat field calibration.

See the user manual for details on downloading and uploading camera files using CamExpert.



Note: Dust accumulation on the lens will not cause vertical lines. However, a heavy accumulation of dust on the lens will eventually degrade the camera's responsivity and focus quality.

Continuously Smeared, Compressed or Stretched Images

When accurate synchronization is not achieved, the image appears smeared in the scan direction.

If the EXSYNC pulses are coming too fast, then the image will appear smeared and stretched in the machine direction. If the pulses are too slow, then the image will appear smeared and compressed.

Check the resolution of the encoder used to generate the EXSYNC pulses, along with the size of the rollers, pulleys, gearing, etc. to ensure that one pulse is generated for one pixel size of travel of the object.

It is also important that the direction of image travel across the sensor is matched to the camera's scan direction, as set by the user. See 'Scan Direction' in the user manual for more information.

If the scan direction is incorrect, then the image will have a significant smear and image artifacts in the scan direction. Changing the scan direction to the opposite direction should resolve this problem.

Refer to 'Camera Orientation' in the user manual to determine the correct direction orientation for the camera.



Note: The lens has a reversing effect on motion. That is, if an object passes the lens-outfitted camera from left to right, the image on the sensor will pass from right to left. The diagrams in the user manual take the lens effect into account.

It is not always possible to establish the exact EXSYNC resolution or lens magnification to ensure accurate synchronization. To alleviate this problem, the camera has a spatial correction feature that can make fine adjustment to restore the alignment. (See section 'Compensating for Encoder Errors' for details.)

Randomly Compressed Images

It is possible that when the scan speed nears the maximum allowed, based on the exposure time used, the image will be randomly compressed and possibly smeared for short periods in the scan direction.

This is indicative of the inspection systems transport mechanism dynamics causing momentary over-speed conditions. The camera can tolerate very short durations of over-speed, but if it lasts too long, then the camera can only maintain its maximum line rate, and some EXSYNC pulses will be ignored, resulting in the occasional compressed image.

The loss EXSYNC due to over-speed may also cause horizontal image artifacts.

Over-speeding may be due to inertia and / or backlash in the mechanical drive mechanism, causing variations around the target speed.

The greater the speed variation, the lower the target speed needs to be to avoid over-speed conditions. If the speed variation can be reduced by eliminating the backlash in the transport mechanism and / or optimizing the motor controller characteristics, then a higher target speed will be achievable.

Distorted Image when Slowing Down Changing Direction

The camera must align the rows in a fashion that accurately follows the object motion.

When the scan direction changes, then the process must reverse to match the reversed image motion across the sensor.

Only when all rows being accumulated have received the same image will the output be correct. Prior to this some lines have been exposed to one direction and other lines exposed to the opposite direction in the accumulated output.

Power Supply Issues

For safe and reliable operation, the camera input supply must be +12 V to +24 V DC.

The power supply to the camera should be suitably current limited, as per the applied input voltage of between +12 V to +24 V.

Assume a worst-case power consumption of +24 W and a 150% current rating for the breaker or fuse.



Note: The camera will not start to draw current until the input supply is above approximately 10.5 V and 200 msec has elapsed. If the power supply stabilizes in less than 200 msec, then inrush current will not exceed normal operating current.

It is important to consider how much voltage loss occurs in the power supply cabling to the camera, particularly if the power cable is long and the supply is operating at +12 V where the current draw is highest.

Reading the input supply voltage as measured by the camera will give an indication of the supply drop being experienced.

The camera tolerates "hot" unplugging and plugging.

The camera has been designed to protect against accidental application of an incorrect input supply, up to reasonable limits.

With the following input power issues, the status LED will be OFF:

- The camera will protect against the application of voltages above approximately +28 V. If the overvoltage protection threshold is exceeded, then power is turned off to the camera's internal circuitry. The power supply must be recycled to recover camera operation. The input protection circuitry is rated up to an absolute maximum of +30 V. Beyond this voltage, the camera may be damaged.
- The camera will also protect against the accidental application of a reverse input supply up to a maximum of -30 V. Beyond this voltage, the camera may be damaged.

Causes for Overheating & Power Shut Down

For reliable operation, the camera's face plate temperature should be kept below +65 °C and the internal temperature kept below +70 °C.

Many applications, such as in clean rooms, cannot tolerate the use of forced air cooling (fans) and therefore must rely on convection.

The camera's body has been designed with integrated heat fins to assist with convection cooling. The fins are sufficient to keep the camera at an acceptable temperature if convection flow is unimpeded.

The camera also benefits from conducting heat away from the body via the face plate into the lens extension tubes and camera mount. It is therefore important not to restrict convection airflow around the camera body, especially the fins and the lens assembly and camera mount. Lowering the ambient temperature will equally lower the camera's temperature.

If the camera's internal temperature exceeds +80 °C, then the camera will partially shut down to protect itself against damage.

Commands can still be sent to the camera to read the temperature, but the image sensor will not be operational and LVAL in response to line triggers will not be generated.

Additionally, the camera's power will reduce to approximately 70% of normal operation. If the camera's temperature continues to rise, at +90 °C the camera will further reduce its power to approximately 30% of normal operation and any communication with the camera will not be possible.

The only means to recover from a thermal shutdown is to turn the camera's power off. Once the camera has cooled down, the camera data can be restored by reapplying power to the camera.

Declarations of Conformity

Copies of the Declarations of Conformity documents are available on the product page on the [Teledyne DALSA website](#) or by request.

FCC Statement of Conformance

This equipment complies with Part 15 of the FCC rules. Operation is subject to the following conditions:

1. The product may not cause harmful interference; and
- 4.
2. The product must accept any interference received, including interference that may cause undesired operation.

FCC Class A Product

This equipment has been tested and found to comply with the limits for a Class A digital device, pursuant to part 15 of the FCC Rules. These limits are designed to provide reasonable protection against harmful interference when the equipment is operated in a commercial environment. This equipment generates, uses, and can radiate radio frequency energy and, if not installed and used in accordance with the instruction manual, may cause harmful interference to radio communications. Operation of this equipment in a residential area is likely to cause harmful interference in which case the user will be required to correct the interference at his own expense.

Changes or modifications not expressly approved by the party responsible for compliance could void the user's authority to operate the equipment.

This equipment is intended to be a component of a larger industrial system.

CE and UKCA Declaration of Conformity

Teledyne DALSA declares that this product complies with applicable standards and regulations.

Changes or modifications not expressly approved by the party responsible for compliance could void the user's authority to operate the equipment.

This product is intended to be a component of a larger system and must be installed as per instructions to ensure compliance.

Document Revision History

| Revision | Description | Date |
|----------|---|-------------------|
| 00 | Initial release. | February 26, 2019 |
| 01 | <ul style="list-style-type: none">Note added that 300 kHz line rate achievable using AOI feature in 8k cameras.Power / GPIO connector pin 8 revised to line 6 out.Added revised mechanical drawings to include θz of $\pm 0.4^\circ$HDR Demo Mode section revised and expanded.Sequential Exposure Mode timing diagram revised. | June 13, 2019 |
| 02 | Added ML-FC-16K04T-00-R model | November 1, 2019 |
| 03 | Added ML-FM-16K07A-00-R and ML-HM-08K30H-00-R models Corrected External Output Timing Reference Updated Notice, Declarations of Conformity and Contact Information. | January 23, 2023 |

Contact Information

Sales Information

Visit our web site:

www.teledynedalsa.com

Email:

info@teledynedalsa.com

Canadian Sales

Teledyne DALSA — Head office
605 McMurray Road
Waterloo, Ontario, Canada, N2V 2E9
Tel: 519 886 6000
Fax: 519 886 8023

Teledyne DALSA — Montreal office
880 Rue McCaffrey
Saint-Laurent, Quebec, Canada, H4T 2C7
Tel: (514) 333-1301
Fax: (514) 333-1388

USA Sales

Teledyne DALSA — Billerica office
700 Technology Park Drive
Billerica, Ma. 01821
Tel: (978) 670-2000
Fax: (978) 670-2010
sales.americas@teledynedalsa.com

European Sales

Teledyne DALSA GMBH
Lise-Meitner-Str. 7
82152 Krailling (Munich), Germany
Tel: +49 - 89 89545730
sales.europe@teledynedalsa.com

Asian Pacific Sales

Teledyne DALSA Asia Pacific
Ikebukuro East 6F
3-4-3 Higashi Ikebukuro,
Toshima-ku, Tokyo, Japan
Tel: +81 3 5960 6353
Fax: +81 3 5960 6354
sales.asia@teledynedalsa.com

Teledyne DALSA Asia Pacific
Room 904, Block C, Poly West Bund Center
75 Rui Ping Road
Shanghai 200032
Tel: +86-21-60131571
sales.asia@teledynedalsa.com

Technical Support

Submit any support question or request via our web site:

Technical support form via our web page:
Support requests for imaging product installations,
Support requests for imaging applications

Camera support information

Product literature and driver updates

<http://www.teledynedalsa.com/mv/support>