

COMPACT Version



- Very intense and uniform illuminated area
- Full range of colors: from UV to IR, white
- Long lifetime and few maintenances
- Compatible with most objectives (C-Mount)
- High depth of field for line version
- No speckle

		Compact version: CPT
Electronics	Connectors	M8, 8 Contacts (no LED driver=no protection)
	Power supply	Direct current
	Illumination mode	Strobe mode only or low constant current (no cooling system)
	Power consumption	Depending on current and LED version
Optics	Wavelength	Various wavelengths (from UV to IR, White)
	Projected pattern	Various designs for alignment, 3D profiling and stereovision / Switchable
Mechanics	Weight	200g
	Width x length	42mm x 71mm (without the objective)
	Objective adjustment	C-mount adaptor on the projector
	Fastener	8 x M5 6H
	Material	Device body: Aluminum alloy
Environment	Working temperature	0°C to 40°C
	IP code	IP54

Applications

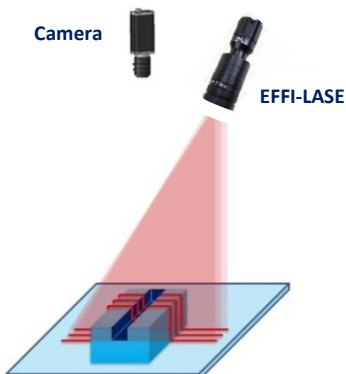

Stereovision and 3D profiling

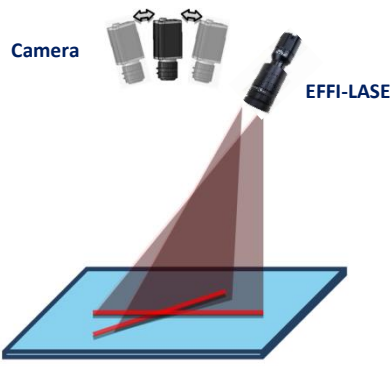

Alignment applications

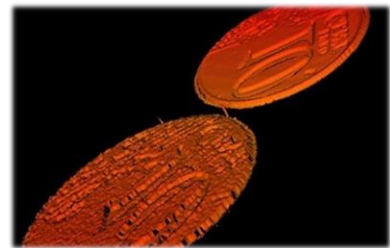

EFFI-LASE (up) vs. Laser (down)
No speckle = more accurate

Part Number



Reference:

Compact: EFFI-LASE-**CPT**-**XXX**-**YYY**-**ZZZ**

XXX: LED Version

LX1*(*recommended for Line pattern)

MX1

MX2

MX3

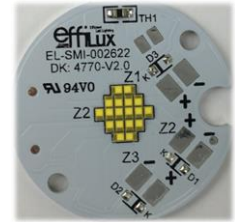

YYY: Wavelength (nm) / Color (other wavelengths available on demand)

● UV 385 or 395 or 405

● Blue 465

● Green 525

● Red 625

● IR 850

○ White 000 (T°= 5500 K ± 500 K)

ZZZ: Type of Mask (custom masks are possible)

3D Profilometry (line length: 13mm)

Stereovision and Alignment

L01	1 line: 50 µm		G01	Round Ø50 µm Surface (mm ²) 10x10 separated by 50 µm	
L02	1 line: 20 µm		G02	Round Ø50 µm Surface (mm ²) 13x13 separated by 50 µm	
L03	1 line: 10 µm		G03	Grid 40*40, lines 50 µm Surface (mm ²) 10x10 separated by 50 µm	
L04	3 lines: 50 µm separated by 500 µm		G04	Grid 50*50, lines 50 µm Surface (mm ²) 13x13 separated by 50 µm	
L05	3 lines: 50 µm separated by 200 µm		G05	Square 50*50 µm ² Surface (mm ²) 10x10 separated by 100 µm	
L06	5 lines: 50 µm separated by 750 µm		C02	Cloud of dots density 50% Surface (mm ²) 12,8x9,6	
L07	100 lines: 45 µm separated by 67,5 µm		C03	Cloud of dots density 17% Surface (mm ²) 12,8x9,6	
L08	22 lines: 50 µm		A01	Cross 50 µm Line length: 13mm	
L09	1 line: 5 µm		A02	Concentric circles	
L41	1 line 75 µm + 40 lines 45 µm		A03	Square 50*50 µm ² Line length: 10mm	

Electronical considerations



Contact arrangement

The EFFI-LASE-CPT is supplied with a direct current through the M8-8 PINS (male).

CONVENTION CABLE M8					
Pin number	Cable color	Contact arrangement	With MX1 or LX1	With MX2	With MX3
1	White	<p>M8 8 PINS (male)</p>	-V _{LED}	-V _{LED} n°1 (Z2)	-V _{LED} n°1 (Z2)
2	Brown		+V _{LED}	+V _{LED} n°1 (Z2)	+V _{LED} n°1 (Z2)
3	Green		N.C	-V _{LED} n°2 (Z1)	-V _{LED} n°2 (Z1)
4	Yellow		N.C	+V _{LED} n°2 (Z1)	+V _{LED} n°2 (Z1)
5	Grey		N.C	N.C	-V _{LED} n°3 (Z3)
6	Pink		N.C	N.C	+V _{LED} n°3 (Z3)
7	Blue		-TH Thermistor	-TH Thermistor	-TH Thermistor
8	Red		+TH Thermistor	+TH Thermistor	+TH Thermistor

LED arrangement			
LX1	MX1	MX2	MX3

Electrical diagram for each channel

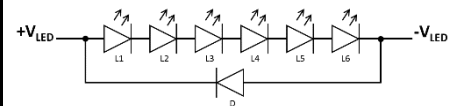

Protective diode **D** TVS 400mW 24V: PTVS24VS1UR

Thermistor NTC 10kΩ **TH1**: VISHAY NTCS0805E3103JMT

Strobe mode

EFFILUX proposes a LED controller (EFFI-IPSC4) which allows you to obtain by software interface the ON time and OFF time that you desire. You can see below 5 possible configurations depending on the current that you provide to the EFFI-LASE-CPT. Contact EFFILUX for more information.

Configuration	Current	Max pulse duration (μs) / τ _{pulse}	D
1	1.2A	50000	0.5
2	1.5A	10000	0.1
3	2A	1000	0.01
4	2.5A	100	0.001
5	3.5A	40	0.0004

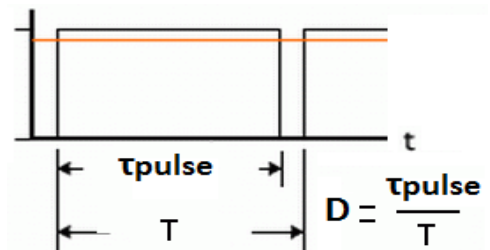

Optical considerations



Any C-mount objective can be mounted on the EFFI-LASE-CPT. The objective is not provided with the EFFI-LASE-CPT.

To guarantee the quality of the projector, the pattern is directly mounted in the projector body. However, the pattern can be observed through the aperture of the projector. Avoid any sharp contact with the mask: this one is sensitive and can easily be damaged.

Objective selection

EFFILUX recommends using one of the following objectives with the EFFI-LASE-V2 (2/3" 1.5MP and 1" 1.5MP):

	OBJ-2-3-F9 HF9HA-1B	OBJ-2-3-F12.5 HF12.5HA-1B	OBJ-2-3-F16 HF16HA-1B	OBJ-2-3-F25 HF25HA-1B	OBJ-2-3-F35 HF35HA-1B	OBJ-2-3-F50 HF50HA-1B	OBJ-2-3-F75 HF75HA-1B	
Focal length (mm)	9	12.5	16	25	35	50	75	
Iris Range	F1.4 – F16				F1.6 – F22		F2.8 – F22	
Angle of View (HxV)	52°06' x 40°16'	38°47' x 29°35'	30°45' x 23° 18'	19° 58' x 15° 02'	14° 20' x 10° 46'	10° 03' x 07° 33'	6° 43' x 5° 02'	
Filter thread	M27 x 0.5 mm	M25.5 x 0.5 mm					M30.5 x 0.5 mm	
L x Ø	35 x 29.5 mm	29.5 x 29.5 mm	29.5 x 29.5 mm	29.5 x 29.5 mm	29.5 x 29.5 mm	29.5 x 29.5 mm	48 x 29.5 mm	
Mechanical characteristics								

	OBJ-1-F12.5 CF12.5HA-1	OBJ-1-F16 CF16HA-1	OBJ-1-F25 CF25HA-1	OBJ-1-F35 CF35HA-1	OBJ-1-F50 CF50HA-1	OBJ-1-F75 CF75HA-1
Focal length (mm)	12.5	16	25	35	50	75
Iris Range	F1.4 – F22				F1.8 – F22	
Angle of View (HxV)	45° 13' x 42° 01'	43° 36' x 33° 24'	28° 43' x 21° 44'	20° 43' x 15° 37'	14° 35' 10° 58'	9° 45' x 7° 19'
Filter thread	M49 x 0.75 mm					
L x Ø	68.5 x 51 mm	70.5 x 51 mm	75.5 x 51 mm	48.5 x 51 mm	55.5 x 51 mm	76 x 51 mm
Mechanical characteristics						

Depending on the working distance (WD) and the C-mount objective selected, different pattern sizes are obtained:

Objective	Line width (mm)			
	Mask dimensions: 13mm x 50µm (L01)			
	WD = 30cm	WD = 50cm	WD = 80cm	WD = 100cm
f = 12.5 mm	1.27	2	3.19	4
f = 16 mm	1.01	1.58	2.40	3
f = 35 mm	0.42	0.71	1.13	1.40
f = 50 mm	0.30	0.49	0.78	0.98
f = 75 mm	n.a	n.a	0.51	0.63

The relation between the line width and the working distance is linear. For a 50µm mask width, the following graphs are obtained:

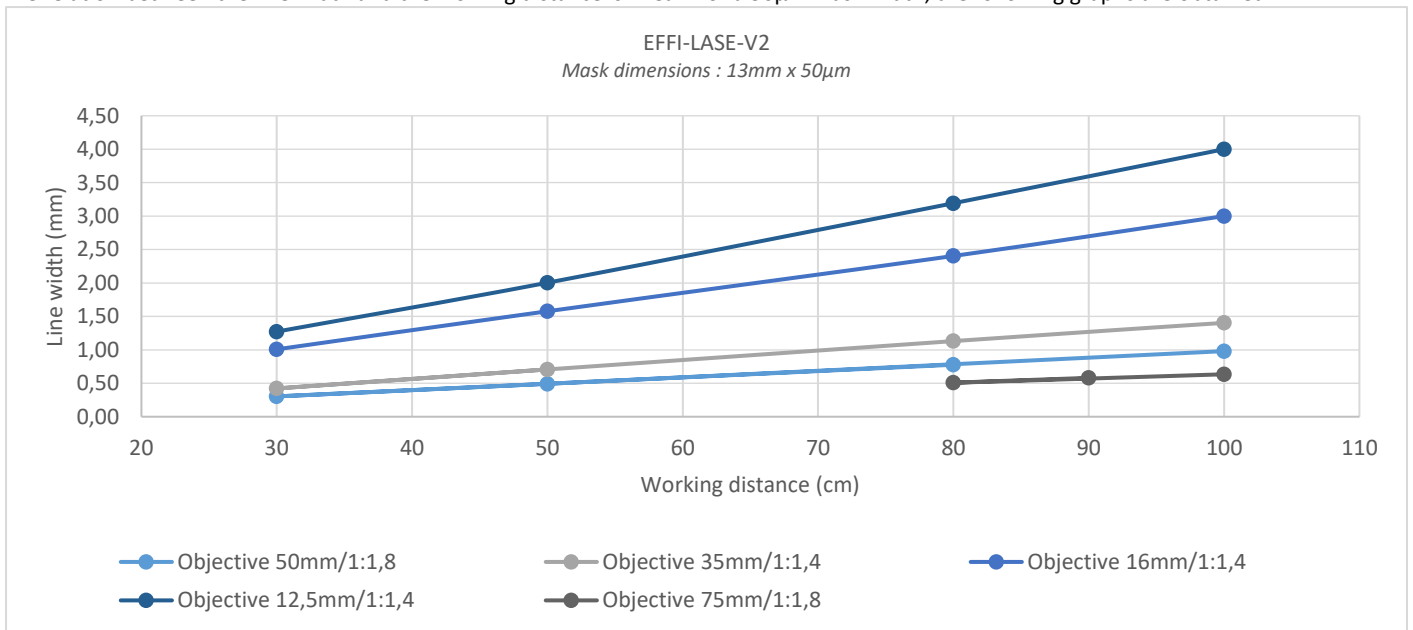

Objective	Pattern dimensions HxW (cm)			
	Dimensions of a 12.8x9.6mm cloud of dots pattern (C02)			
	WD = 30cm	WD = 50cm	WD = 80cm	WD = 100cm
f = 12.5 mm	32 x 23	51 x 37	82 x 59	102 x 73
f = 16 mm	25 x 19	41 x 31	66 x 49	82 x 61
f = 35 mm	11 x 8	18 x 14	29 x 22	36 x 27
f = 50 mm	n.a	12 x 9	20 x 15	25 X 19
f = 75 mm	n.a	n.a	13 x 10	16 x 12

Mechanical considerations (Dimensions in mm)

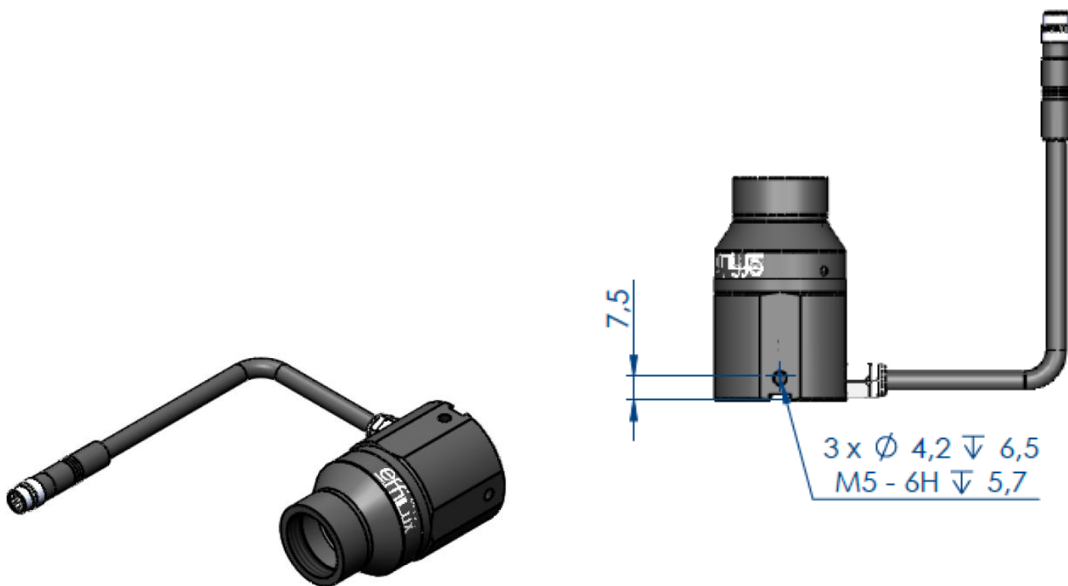
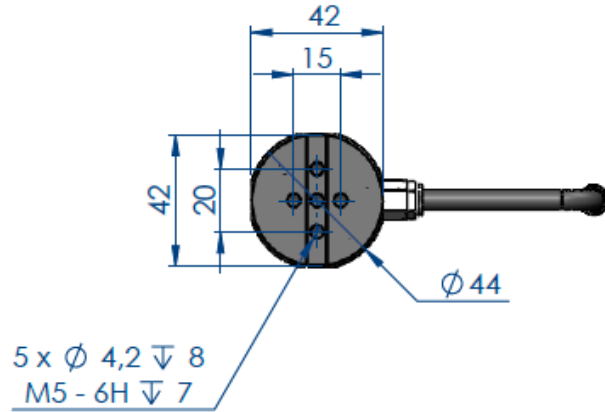
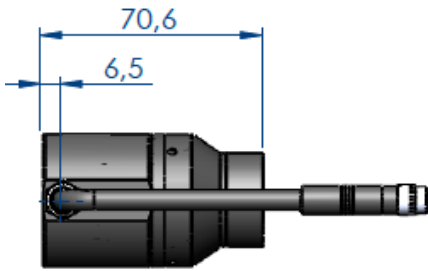
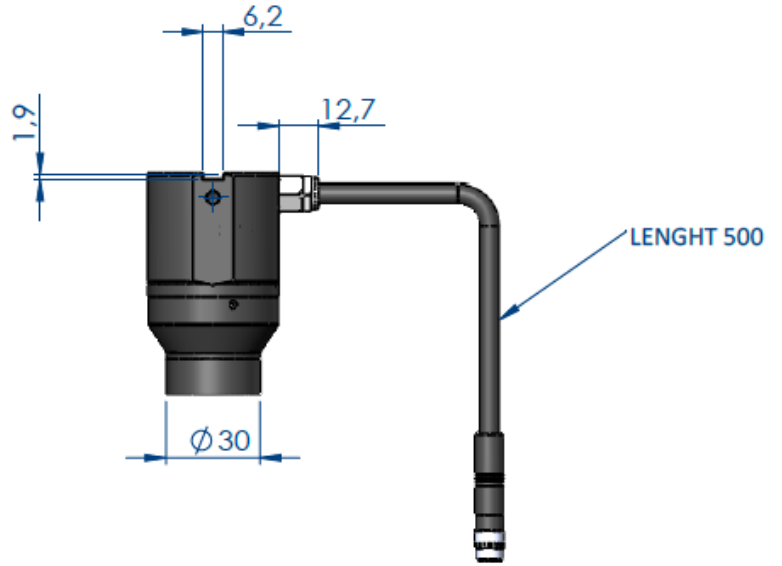

Configurations

Three examples of recommended configurations:

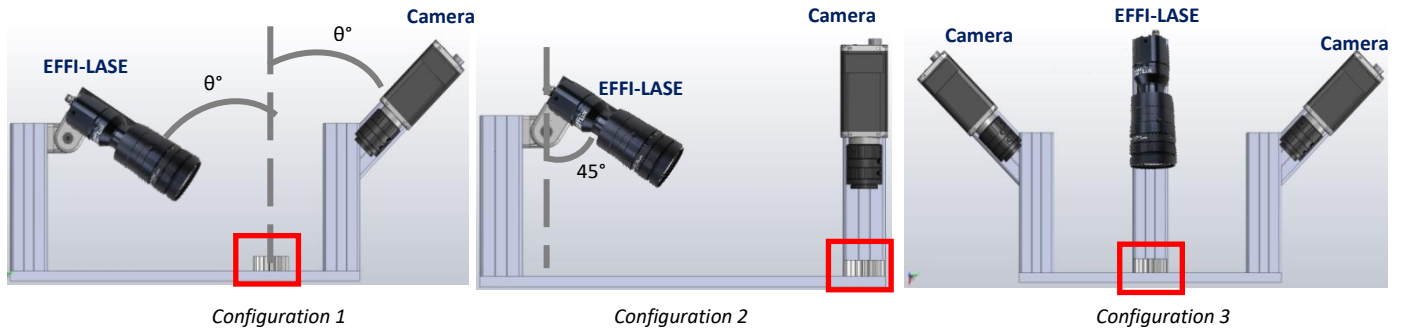

The selection between configuration 1 and configuration 2 depends on the object to observe: either the specular reflection needs to be captured (configuration 1) or reflections different from the specular reflections (configuration 2) are considered.

Use the fixings that you can see on the mechanical considerations to place and fix the EFFI-LASE-CPT correctly and efficiently.

N.B: Keep in mind that, all the pictures below (page 10/11/12) are with the PASSIVE Version but it will work for the COMPACT Version. The way to change the mask or the way to align correctly the mask are the same for both versions.

Quick Start



1 Ready



2 Screw the objective

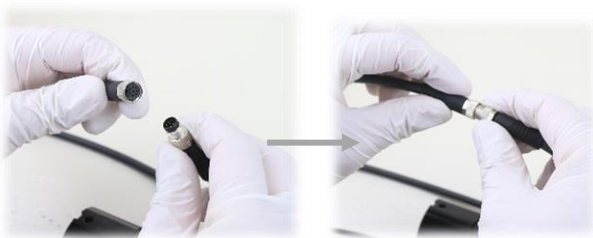

3 Plug the M8 connector*



4 Turn ON and use the product

*You can plug the M8 directly to your own power supply or to the EFFILUX over molded drivers.

⚠ Direct current

Alignment between LED and the Mask



This part concerns you only if you got **A LINEAR LED VERSION** (LX1). To have an optimized depth of field, you need to align the mask with the LEDs. We recommend to use linear masks for the LX1 LED Version, the mask used is the L03 (one line) for the example. We apologize for the darkness of the pictures, we needed to show you the light form to help you to align correctly your mask.

N.B: Always checking the step 7 by adjusting the objective!

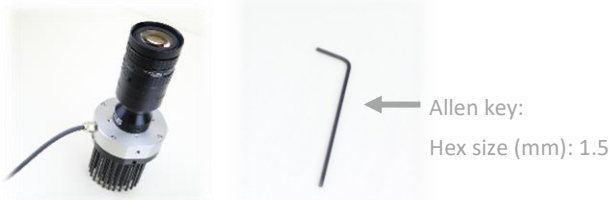

Allen key:
Hex size (mm): 1.5

1 Ready (with Allen key*)

*The Allen key will allow you to unscrew the optical head to adjust it correctly.

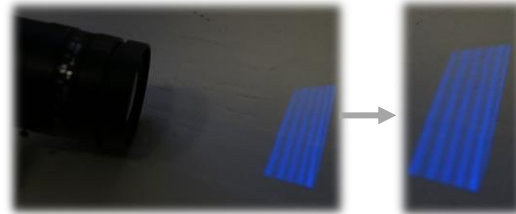

The objective needs to be **defocused**. Remember, we are supposed to have one line. (mask L03)

2 Wrong alignment

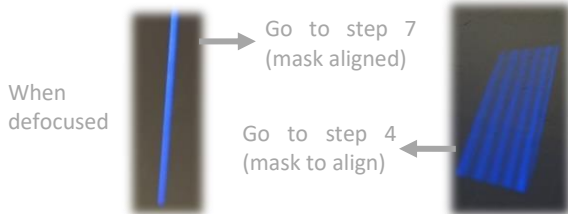

When defocused

Go to step 7
(mask aligned)

Go to step 4
(mask to align)

3 Checking light form

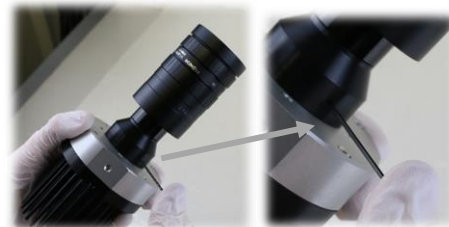

Use the Allen key for unscrewing the **2 screws**, hex size (mm): 1.5

4 Unscrew the optical head



Turn the optical head

One line is the right form (mask form) to have when it is **defocused!**

5 Obtain the right form



You are supposed to have a good alignment, so you can fix the optical head by screwing the **2 screws** (Hex size: 1,5 mm).

6 Screw the optical head

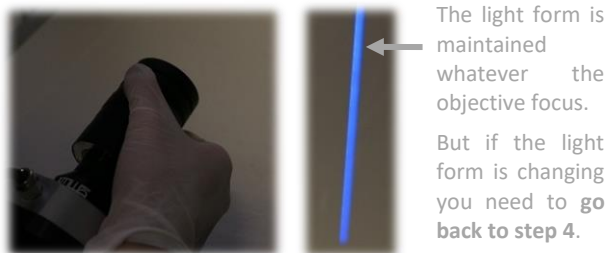

The light form is maintained whatever the objective focus. But if the light form is changing you need to go **back to step 4**.

7 Checking alignment

Now you can adjust the focus for the clearness of the light form.



The EFFI-LASE is now ready to be used efficiently!

8 Good alignment

Change the mask



Before trying to change the mask, please **disconnect** the product and **unscrew** the C-mount objective. Then, you can follow the steps below. It is recommended to use **gloves**.



The three items are needed for the following steps.

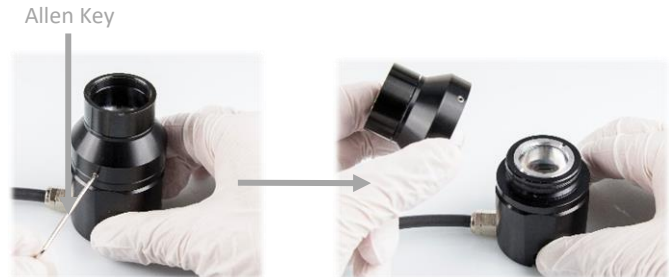

1 Ready

2 Unscrew the optical head



There is a cover in front of the mask that you have to remove from behind.
No need to unscrew.



3 Unscrew the C-mount & ring

4 Remove the mask carefully

You must see the reference of the mask (L08, L03...) when you place it into the optical head.



5 Place the new mask (L03)

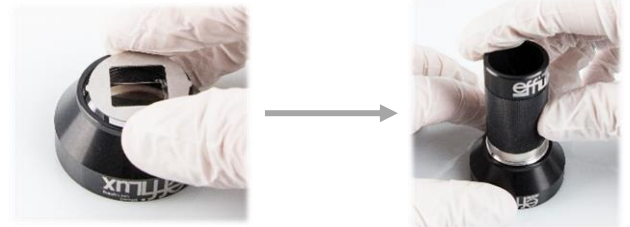

6 Place the cover & Ring

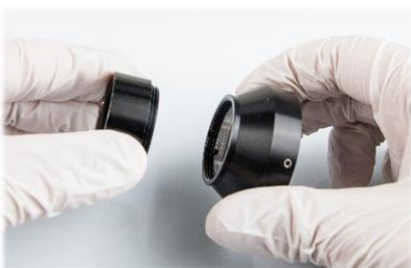

7 Place and screw the C-mount

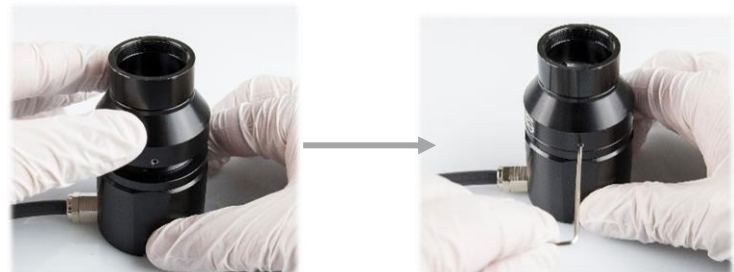

The EFFI-LASE is ready to be used with the new mask!
Please refer to the step alignment with the mask if needed.

8 Screw the optical head

Remember that the "Change the mask" part works with all the EFFI-LASE Version (PSV, FAN, CPT) even if the pictures are with a CPT.

N.B: If you did not to succeed the steps for one of the three parts. Please feel free to contact us.

EFFI-IPSC4 accessory (to purchase separately)



EFFILUX provides an over molded SuBD-Male / M8-Female-8 PINs cable to plug the EFFI-LASE-CPT to an EFFI-IPSC4. The colors and the signals are corresponding with the array for the M8 connector above (page 3)

OUTPUT Connector :
M8 Female 8 contacts

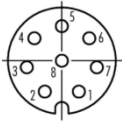

Length Cable
2, 5 or 10 meters

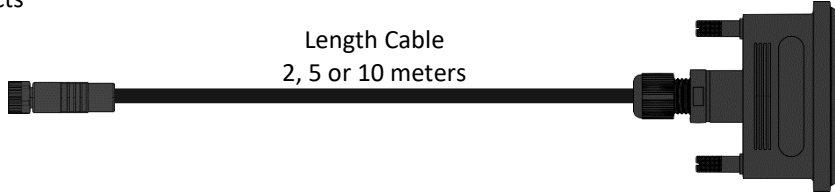

INPUT Connector :
SuBD Male



SUBD / M8 CONNECTOR 8 CONTACTS								
Cable color	SUBD Contact arrangement (Male)		Designation	M8 Contact arrangement (Female)	With MX1 / LX1	With MX2	With MX3	
White		1	GND Channel 1		1	-V _{LED}	-V _{LED} n°1 (Z2)	-V _{LED} n°1 (Z2)
Brown		A3	+Vcommon		2	+V _{LED}	+V _{LED} n°1 (Z2)	+V _{LED} n°1 (Z2)
Green		2	GND Channel 2		3	n.c.	-V _{LED} n°2 (Z1)	-V _{LED} n°2 (Z1)
Yellow		A3	+Vcommon		4	n.c.	+V _{LED} n°2 (Z1)	+V _{LED} n°2 (Z1)
Grey		3	GND Channel 3		5	n.c.	n.c.	-V _{LED} n°3 (Z3)
Pink		A3	+Vcommon		6	n.c.	n.c.	+V _{LED} n°3 (Z3)
Blue		n.c.	n.c.		7	-TH Thermistor	-TH Thermistor	-TH Thermistor
Red		n.c.	n.c.		8	+TH Thermistor	+TH Thermistor	+TH Thermistor

EFFILUX provides cables to integrate the EFFI-LASE + EFFI-IPSC4 into your process.

Cables (other length on request)	EFFI-IPSC4
2 meters: EFFC-CAB-M8-SUBD-FM-8-DD-L2	<p>Strobe controller with 4 Channels Up to 10A per channel (in pulse mode) Pulse width from 1µs to continuous mode</p>
5 meters: EFFC-CAB-M8-SUBD-FM-8-DD-L5	
10 meters: EFFC-CAB-M8-SUBD-FM-8-DD-L10	