

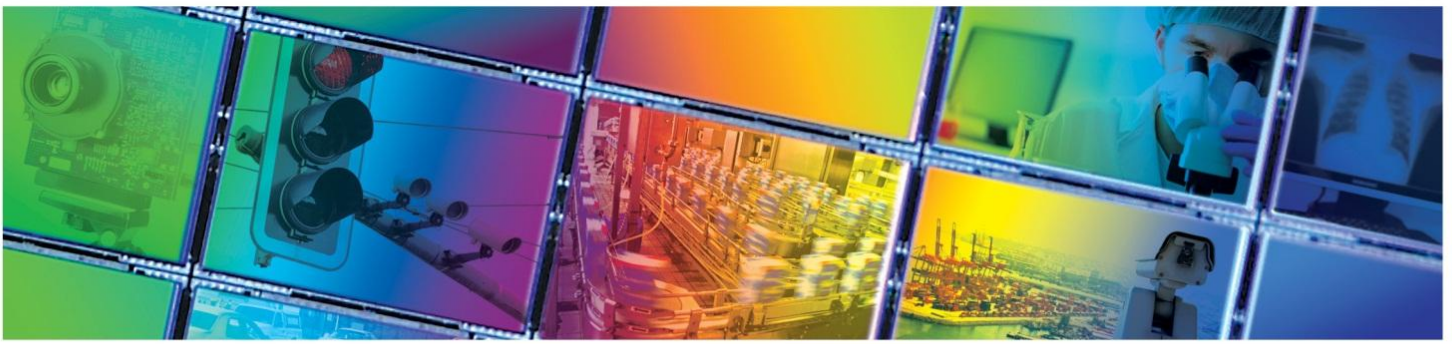

KAI-29050 IMAGE SENSOR  
6576 (H) X 4384 (V) INTERLINE CCD IMAGE SENSOR



JANUARY 16, 2013  
DEVICE PERFORMANCE SPECIFICATION  
REVISION 2.0 PS-0008

## TABLE OF CONTENTS

<b>Summary Specification .....</b>	<b>5</b>
Description .....	5
Features .....	5
Applications .....	5
<b>Ordering Information .....</b>	<b>6</b>
<b>Device Description .....</b>	<b>7</b>
Architecture .....	7
Dark Reference Pixels .....	8
Dummy Pixels .....	8
Active Buffer Pixels.....	8
Image Acquisition .....	8
ESD Protection .....	8
Bayer Color Filter Pattern .....	9
TRUESENSE Sparse Color Filter Pattern .....	9
Physical Description .....	10
Pin Description and Device Orientation .....	10
<b>Imaging Performance .....</b>	<b>12</b>
Typical Operation Conditions .....	12
Specifications.....	12
All Configurations .....	12
KAI-29050-AXA and KAI-29050-PXA Configurations .....	13
KAI-29050-CXA and KAI-29050-PXA Configurations .....	13
<b>Typical Performance Curves .....</b>	<b>14</b>
Quantum Efficiency.....	14
Monochrome with Microlens.....	14
Color (Bayer RGB) with Microlens .....	15
Color (TRUESENSE Sparse CFA) with Microlens .....	15
Angular Quantum Efficiency.....	16
Monochrome with Microlens.....	16
Dark Current versus Temperature .....	16
Power – Estimated .....	17
Frame Rates .....	17
<b>Defect Definitions .....</b>	<b>18</b>
Operation Conditions for Defect Testing at 40 °C .....	18
Defect Definitions for Testing at 40 °C .....	18
Operation Conditions for Defect Testing at 27 °C .....	19
Defect Definitions for Testing at 27 °C.....	19
Defect Map.....	19
<b>Test Definitions .....</b>	<b>20</b>
Test Regions of Interest .....	20
OverClocking .....	20
Tests.....	21
Dark Field Global Non-Uniformity.....	21
Global Non-Uniformity.....	21
Global Peak to Peak Non-Uniformity.....	21
Center Non-Uniformity .....	22
Dark field Defect Test .....	22
Bright field Defect Test .....	22

<b>Operation</b> .....	<b>23</b>
Absolute Maximum Ratings .....	23
Absolute Maximum Voltage Ratings Between Pins and Ground .....	23
Power Up and Power Down Sequence .....	24
DC Bias Operating Conditions.....	25
AC Operating Conditions.....	26
Clock Levels .....	26
Device Identification.....	27
Recommended Circuit.....	27
<b>Timing</b> .....	<b>28</b>
Requirements and Characteristics .....	28
Timing Diagrams .....	29
Photodiode Transfer Timing.....	30
Line and Pixel Timing.....	30
Pixel Timing Detail .....	31
Frame/Electronic Shutter Timing .....	31
VCCD Clock Edge Alignment .....	31
Line and Pixel Timing – Vertical Binning by 2 .....	32
Fast Line Dump Timing.....	32
<b>Storage and Handling</b> .....	<b>33</b>
Storage Conditions.....	33
ESD .....	33
Cover Glass Care and Cleanliness .....	33
Environmental Exposure .....	33
Soldering Recommendations .....	33
<b>Mechanical Information</b> .....	<b>34</b>
Completed Assembly.....	34
Cover Glass.....	36
Cover Glass Transmission .....	37
<b>Quality Assurance and Reliability</b> .....	<b>38</b>
Quality and Reliability .....	38
Replacement.....	38
Liability of the Supplier .....	38
Liability of the Customer .....	38
Test Data Retention.....	38
Mechanical.....	38
<b>Life Support Applications Policy</b> .....	<b>38</b>
<b>Revision Changes</b> .....	<b>39</b>
MTD/PS-1196.....	39
PS-0008 .....	39

## TABLE OF FIGURES

Figure 1: Block Diagram .....	7
Figure 2: Bayer Color Filter Pattern .....	9
Figure 3: TRUESENSE Sparse Color Filter Pattern .....	9
Figure 4: Package Pin Designations - Top View.....	10
Figure 5: Monochrome with Microlens Quantum Efficiency.....	14
Figure 6: Color (Bayer) with Microlens Quantum Efficiency .....	15
Figure 7: Color (TRUESENSE Sparse CFA) with Microlens Quantum Efficiency .....	15
Figure 8: Monochrome with Microlens Angular Quantum Efficiency.....	16
Figure 9: Dark Current versus Temperature .....	16
Figure 10: Power .....	17
Figure 11: Frame Rates.....	17
Figure 12: Regions of Interest .....	20
Figure 13: Power Up and Power Down Sequence .....	24
Figure 14: Output Amplifier .....	25
Figure 15: Device Identification Recommended Circuit .....	27
Figure 16: Photodiode Transfer Timing .....	30
Figure 17: Line and Pixel Timing .....	30
Figure 18: Pixel Timing Detail.....	31
Figure 19: Frame/Electronic Shutter Timing.....	31
Figure 20: VCCD Clock Rise Time, Fall Time and Edge Alignment.....	31
Figure 21: Line and Pixel Timing - Vertical Binning by 2 .....	32
Figure 22: Fast Line Dump Timing .....	32
Figure 23: Completed Assembly (1 of 2) .....	34
Figure 24: Completed Assembly (2 of 2) .....	35
Figure 25: Cover Glass .....	36
Figure 26: Cover Glass Transmission.....	37

## Summary Specification

### KAI-29050 Image Sensor

#### DESCRIPTION

The KAI-29050 Image Sensor is a 29-megapixel CCD in a 35 mm optical format. Based on the TRUESENSE 5.5 micron Interline Transfer CCD Platform, the sensor features broad dynamic range, excellent imaging performance, and a flexible readout architecture that enables use of 1, 2, or 4 outputs for full resolution readout up to 4 frames per second. A vertical overflow drain structure suppresses image blooming and enables electronic shuttering for precise exposure control.

The sensor is available with the TRUESENSE Sparse Color Filter Pattern, a technology which provides a 2x improvement in light sensitivity compared to a standard color Bayer part.

The sensor shares common PGA pin-out and electrical configurations with other devices based on the TRUESENSE 5.5 micron Interline Transfer CCD Platform, allowing a single camera design to be leveraged to support multiple members of this sensor family.

#### FEATURES

- Bayer Color Pattern, TRUESENSE Sparse Color Filter Pattern, and Monochrome configurations
- Progressive scan readout
- Flexible readout architecture
- High frame rate
- High sensitivity
- Low noise architecture
- Excellent smear performance
- Package pin reserved for device identification

#### APPLICATIONS

- Industrial Imaging and Inspection
- Medical Imaging
- Security



Parameter	Typical Value
Architecture	Interline CCD; Progressive Scan
Total Number of Pixels	6644 (H) x 4452 (V)
Number of Effective Pixels	6600 (H) x 4408 (V)
Number of Active Pixels	6576 (H) x 4384 (V)
Pixel Size	5.5 $\mu\text{m}$ (H) x 5.5 $\mu\text{m}$ (V)
Active Image Size	36.17 mm (H) x 24.11 mm (V) 43.47 mm (diag) 35 mm optical format
Aspect Ratio	3:2
Number of Outputs	1, 2, or 4
Charge Capacity	20,000 electrons
Output Sensitivity	34 $\mu\text{V}/e^-$
Quantum Efficiency KAI-29050-AXA KAI-29050-CXA	46% (500 nm) 31%, 43%, 42% (620, 540, and 470 nm)
Read Noise (f= 32MHz)	12 electrons rms
Dark Current Photodiode VCCD	7 electrons/s 140 electrons/s
Dark Current Doubling Temp Photodiode VCCD	7 $^{\circ}\text{C}$ 9 $^{\circ}\text{C}$
Dynamic Range	64 dB
Charge Transfer Efficiency	0.999999
Blooming Suppression	> 300 X
Smear	Estimated -100 dB
Image Lag	< 10 electrons
Maximum Pixel Clock Speed	40 MHz
Maximum Frame Rates Quad Output Dual Output Single Output	4 fps 2 fps 1 fps
Package	72 pin PGA
Cover Glass	AR Coated, 2 Sides

All parameters are specified at T = 40  $^{\circ}\text{C}$  unless otherwise noted.

## Ordering Information

Catalog Number	Product Name	Description	Marking Code
4H2166	KAI-29050-AXA-JD-B1	Monochrome, Special Microlens, PGA Package, Sealed Clear Cover Glass with AR coating (both sides), Grade 1	KAI-29050-AXA Serial Number
4H2167	KAI-29050-AXA-JD-B2	Monochrome, Special Microlens, PGA Package, Sealed Clear Cover Glass with AR coating (both sides), Grade 2	
4H2168	KAI-29050-AXA-JD-AE	Monochrome, Special Microlens, PGA Package, Sealed Clear Cover Glass with AR coating (both sides), Engineering Grade	
4H2169	KAI-29050-AXA-JR-B1	Monochrome, Special Microlens, PGA Package, Taped Clear Cover Glass with AR coating (both sides), Grade 1	
4H2170	KAI-29050-AXA-JR-B2	Monochrome, Special Microlens, PGA Package, Taped Clear Cover Glass with AR coating (both sides), Grade 2	
4H2171	KAI-29050-AXA-JR-AE	Monochrome, Special Microlens, PGA Package, Taped Clear Cover Glass with AR coating (both sides), Engineering Grade	
4H2172	KAI-29050-CXA-JD-B1	Color (Bayer RGB), Special Microlens, PGA Package, Sealed Clear Cover Glass with AR coating (both sides), Grade 1	KAI-29050-CXA Serial Number
4H2173	KAI-29050-CXA-JD-B2	Color (Bayer RGB), Special Microlens, PGA Package, Sealed Clear Cover Glass with AR coating (both sides), Grade 2	
4H2174	KAI-29050-CXA-JD-AE	Color (Bayer RGB), Special Microlens, PGA Package, Sealed Clear Cover Glass with AR coating (both sides), Engineering Grade	
4H2175	KAI-29050-PXA-JD-B1	Color (TRUESENSE Sparse CFA), Special Microlens, PGA Package, Sealed Clear Cover Glass with AR coating (both sides), Grade 1	KAI-29050-PXA Serial Number
4H2176	KAI-29050-PXA-JD-B2	Color (TRUESENSE Sparse CFA), Special Microlens, PGA Package, Sealed Clear Cover Glass with AR coating (both sides), Grade 2	
4H2177	KAI-29050-PXA-JD-AE	Color (TRUESENSE Sparse CFA), Special Microlens, PGA Package, Sealed Clear Cover Glass with AR coating (both sides), Engineering Grade	

See Application Note *Product Naming Convention* for a full description of the naming convention used for Truesense Imaging image sensors. For reference documentation, including information on evaluation kits, please visit our web site at [www.truesenseimaging.com](http://www.truesenseimaging.com).

Please address all inquiries and purchase orders to:

Truesense Imaging, Inc.  
 1964 Lake Avenue  
 Rochester, New York 14615

Phone: (585) 784-5500  
 E-mail: [info@truesenseimaging.com](mailto:info@truesenseimaging.com)

Truesense Imaging reserves the right to change any information contained herein without notice. All information furnished by Truesense Imaging is believed to be accurate.

## Device Description

### ARCHITECTURE

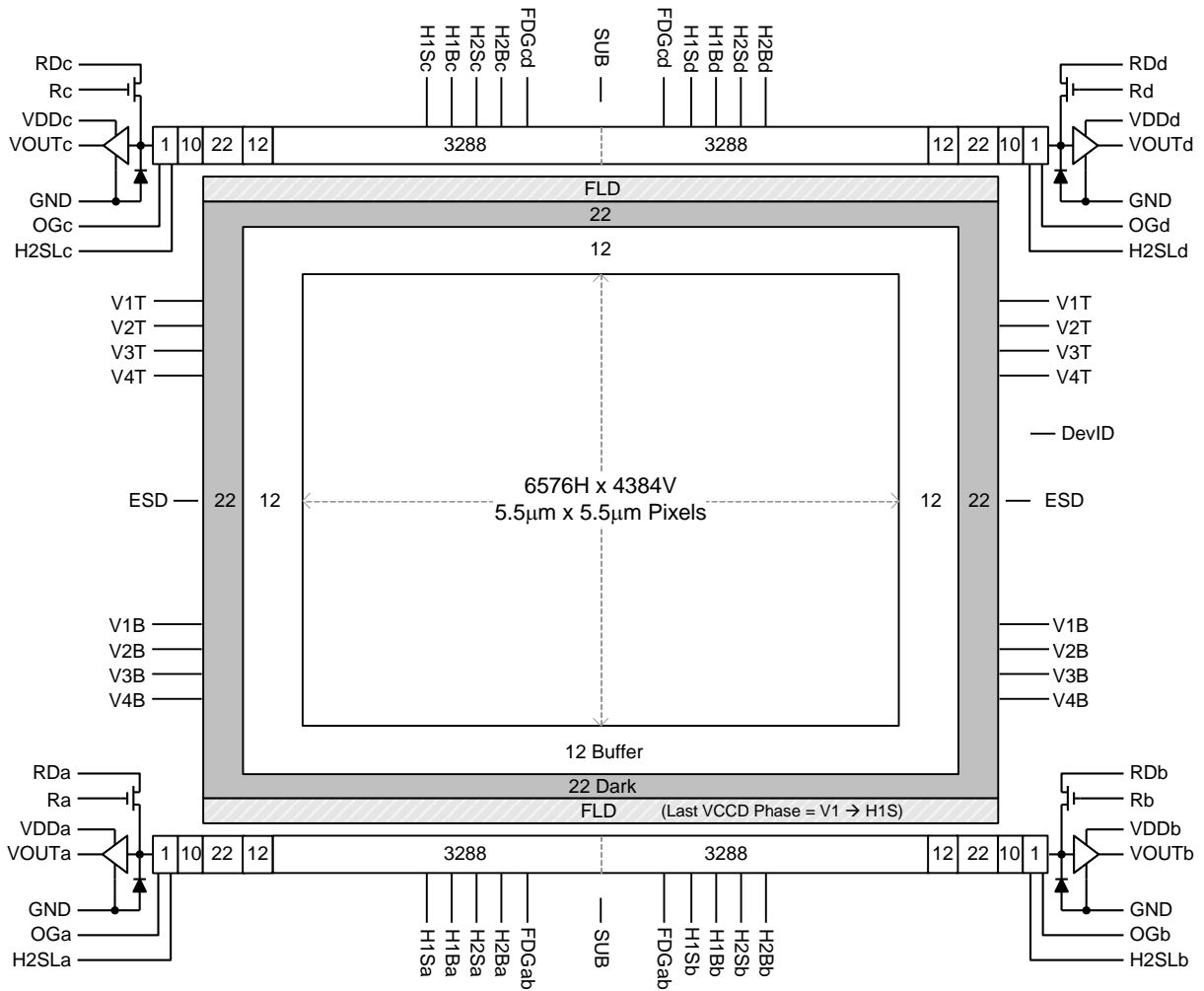

Figure 1: Block Diagram

## **DARK REFERENCE PIXELS**

There are 22 dark reference rows at the top and 22 dark rows at the bottom of the image sensor. The dark rows are not entirely dark and so should not be used for a dark reference level. Use the 22 dark columns on the left or right side of the image sensor as a dark reference.

Under normal circumstances use only the center 20 columns of the 22 column dark reference due to potential light leakage.

## **DUMMY PIXELS**

Within each horizontal shift register there are 11 leading additional shift phases. These pixels are designated as dummy pixels and should not be used to determine a dark reference level.

In addition, there is one dummy row of pixels at the top and bottom of the image.

## **ACTIVE BUFFER PIXELS**

12 unshielded pixels adjacent to any leading or trailing dark reference regions are classified as active buffer pixels. These pixels are light sensitive but are not tested for defects and non-uniformities.

## **IMAGE ACQUISITION**

An electronic representation of an image is formed when incident photons falling on the sensor plane create electron-hole pairs within the individual silicon photodiodes. These photoelectrons are collected locally by the formation of potential wells at each photosite. Below photodiode saturation, the number of photoelectrons collected at each pixel is linearly dependent upon light level and exposure time and non-linearly dependent on wavelength. When the photodiodes charge capacity is reached, excess electrons are discharged into the substrate to prevent blooming

## **ESD PROTECTION**

Adherence to the power-up and power-down sequence is critical. Failure to follow the proper power-up and power-down sequences may cause damage to the sensor. See Power Up and Power Down Sequence section.



### BAYER COLOR FILTER PATTERN

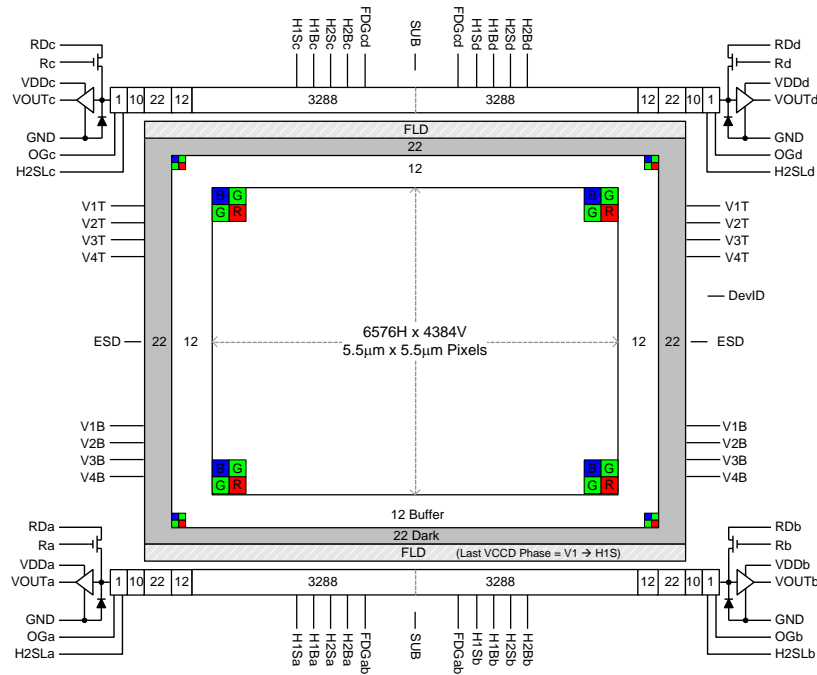

Figure 2: Bayer Color Filter Pattern

### TRUESENSE SPARSE COLOR FILTER PATTERN

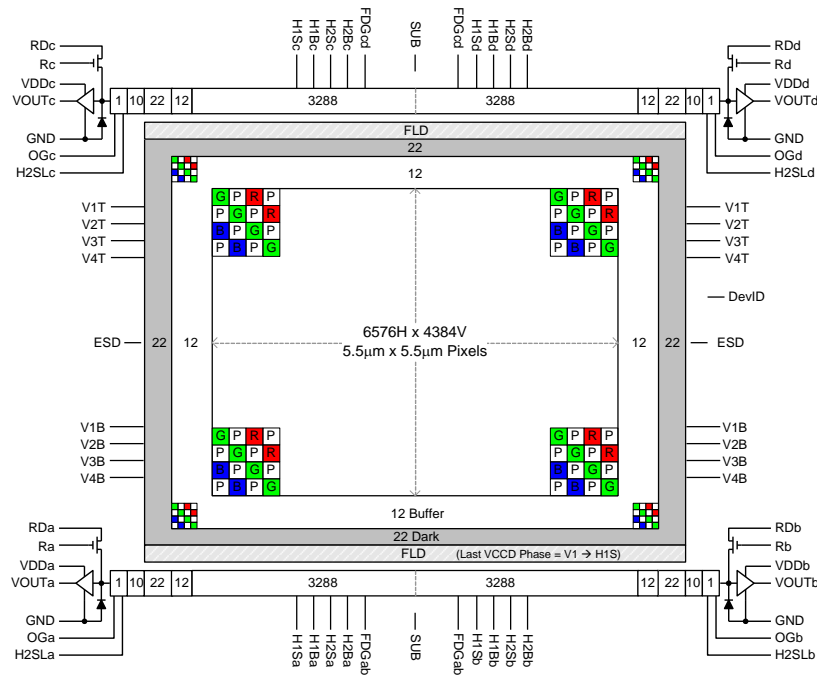

Figure 3: TRUESENSE Sparse Color Filter Pattern

## PHYSICAL DESCRIPTION

### Pin Description and Device Orientation

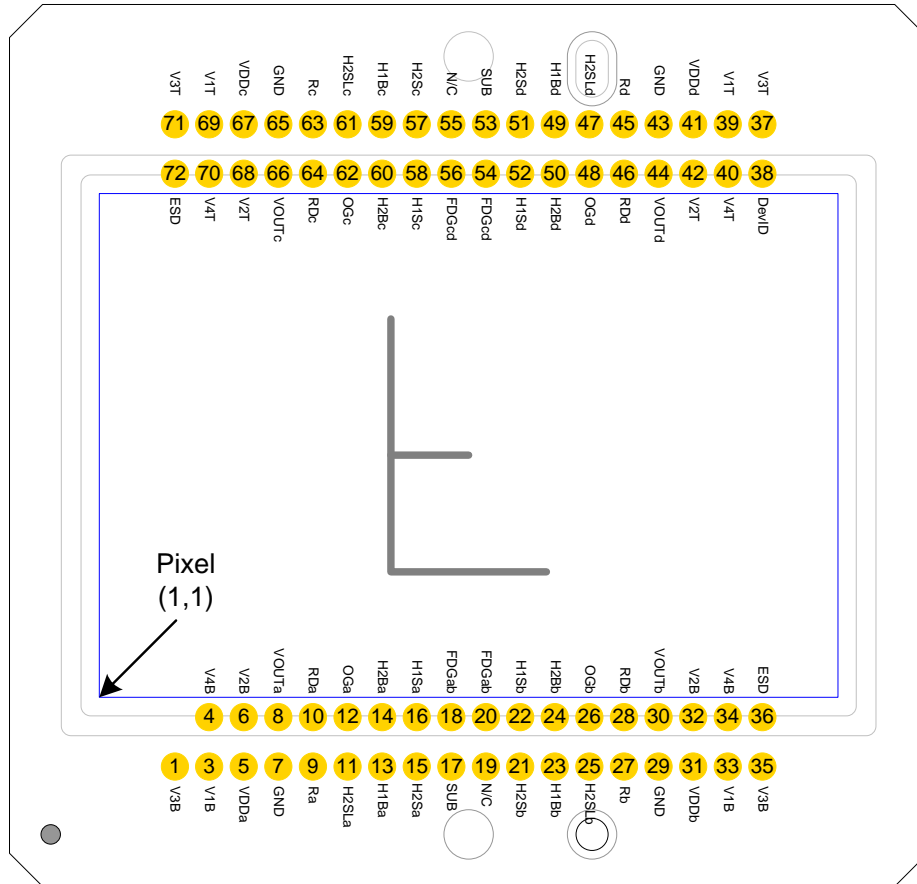

Figure 4: Package Pin Designations - Top View

Pin	Name	Description
1	V3B	Vertical CCD Clock, Phase 3, Bottom
3	V1B	Vertical CCD Clock, Phase 1, Bottom
4	V4B	Vertical CCD Clock, Phase 4, Bottom
5	VDDa	Output Amplifier Supply, Quadrant a
6	V2B	Vertical CCD Clock, Phase 2, Bottom
7	GND	Ground
8	VOUTa	Video Output, Quadrant a
9	Ra	Reset Gate, Quadrant a
10	RDa	Reset Drain, Quadrant a
11	H2SLa	Horizontal CCD Clock, Phase 2, Storage, Last Phase, Quadrant a
12	OGa	Output Gate, Quadrant a
13	H1Ba	Horizontal CCD Clock, Phase 1, Barrier, Quadrant a
14	H2Ba	Horizontal CCD Clock, Phase 2, Barrier, Quadrant a
15	H2Sa	Horizontal CCD Clock, Phase 2, Storage, Quadrant a
16	H1Sa	Horizontal CCD Clock, Phase 1, Storage, Quadrant a
17	SUB	Substrate
18	FDGab	Fast Line Dump Gate, Bottom
19	N/C	No Connect
20	FDGab	Fast Line Dump Gate, Bottom
21	H2Sb	Horizontal CCD Clock, Phase 2, Storage, Quadrant b
22	H1Sb	Horizontal CCD Clock, Phase 1, Storage, Quadrant b
23	H1Bb	Horizontal CCD Clock, Phase 1, Barrier, Quadrant b
24	H2Bb	Horizontal CCD Clock, Phase 2, Barrier, Quadrant b
25	H2SLb	Horizontal CCD Clock, Phase 2, Storage, Last Phase, Quadrant b
26	OGb	Output Gate, Quadrant b
27	Rb	Reset Gate, Quadrant b
28	RDb	Reset Drain, Quadrant b
29	GND	Ground
30	VOUTb	Video Output, Quadrant b
31	VDDb	Output Amplifier Supply, Quadrant b
32	V2B	Vertical CCD Clock, Phase 2, Bottom
33	V1B	Vertical CCD Clock, Phase 1, Bottom
34	V4B	Vertical CCD Clock, Phase 4, Bottom
35	V3B	Vertical CCD Clock, Phase 3, Bottom
36	ESD	ESD Protection Disable

Pin	Name	Description
72	ESD	ESD Protection Disable
71	V3T	Vertical CCD Clock, Phase 3, Top
70	V4T	Vertical CCD Clock, Phase 4, Top
69	V1T	Vertical CCD Clock, Phase 1, Top
68	V2T	Vertical CCD Clock, Phase 2, Top
67	VDDc	Output Amplifier Supply, Quadrant c
66	VOUTc	Video Output, Quadrant c
65	GND	Ground
64	RDc	Reset Drain, Quadrant c
63	Rc	Reset Gate, Quadrant c
62	OGc	Output Gate, Quadrant c
61	H2SLc	Horizontal CCD Clock, Phase 2, Storage, Last Phase, Quadrant c
60	H2Bc	Horizontal CCD Clock, Phase 2, Barrier, Quadrant c
59	H1Bc	Horizontal CCD Clock, Phase 1, Barrier, Quadrant c
58	H1Sc	Horizontal CCD Clock, Phase 1, Storage, Quadrant c
57	H2Sc	Horizontal CCD Clock, Phase 2, Storage, Quadrant c
56	FDGcd	Fast Line Dump Gate, Top
55	N/C	No Connect
54	FDGcd	Fast Line Dump Gate, Top
53	SUB	Substrate
52	H1Sd	Horizontal CCD Clock, Phase 1, Storage, Quadrant d
51	H2Sd	Horizontal CCD Clock, Phase 2, Storage, Quadrant d
50	H2Bd	Horizontal CCD Clock, Phase 2, Barrier, Quadrant d
49	H1Bd	Horizontal CCD Clock, Phase 1, Barrier, Quadrant d
48	OGd	Output Gate, Quadrant b
47	H2SLd	Horizontal CCD Clock, Phase 2, Storage, Last Phase, Quadrant d
46	RDd	Reset Drain, Quadrant d
45	Rd	Reset Gate, Quadrant d
44	VOUTd	Video Output, Quadrant d
43	GND	Ground
42	V2T	Vertical CCD Clock, Phase 2, Top
41	VDDd	Output Amplifier Supply, Quadrant d
40	V4T	Vertical CCD Clock, Phase 4, Top
39	V1T	Vertical CCD Clock, Phase 1, Top
38	DevID	Device Identification
37	V3T	Vertical CCD Clock, Phase 3, Top

**Notes:**

1. Liked named pins are internally connected and should have a common drive signal.
2. N/C pins (19, 55) should be left floating.

## Imaging Performance

### TYPICAL OPERATION CONDITIONS

Unless otherwise noted, the Imaging Performance Specifications are measured using the following conditions.

Description	Condition	Notes
Light Source	Continuous red, green and blue LED illumination	1
Operation	Nominal operating voltages and timing	

Notes:

- For monochrome sensor, only green LED used.

### SPECIFICATIONS

#### All Configurations

Description	Symbol	Min.	Nom.	Max.	Units	Sampling Plan	Temperature Tested At (°C)	Notes
Dark Field Global Non-Uniformity	DSNU	-	-	5	mVpp	Die	27, 40	
Bright Field Global Non-Uniformity		-	2	5	%rms	Die	27, 40	1
Bright Field Global Peak to Peak Non-Uniformity	PRNU	-	10	30	%pp	Die	27, 40	1
Bright Field Center Non-Uniformity		-	1	2	%rms	Die	27, 40	1
Maximum Photoresponse Nonlinearity	NL	-	2	-	%	Design		2
Maximum Gain Difference Between Outputs	$\Delta G$	-	10	-	%	Design		2
Maximum Signal Error due to Nonlinearity Differences	$\Delta NL$	-	1	-	%	Design		2
Horizontal CCD Charge Capacity	HNe	-	50	-	ke <sup>-</sup>	Design		
Vertical CCD Charge Capacity	VNe	-	45	-	ke <sup>-</sup>	Design		
Photodiode Charge Capacity	PNe	-	20	-	ke <sup>-</sup>	Die	27, 40	3
Horizontal CCD Charge Transfer Efficiency	HCTE	0.999995	0.999999	-		Die		
Vertical CCD Charge Transfer Efficiency	VCTE	0.999995	0.999999	-		Die		
Photodiode Dark Current	I <sub>pd</sub>	-	7	70	e/p/s	Die	40	
Vertical CCD Dark Current	I <sub>vd</sub>	-	140	400	e/p/s	Die	40	
Image Lag	Lag	-	-	10	e <sup>-</sup>	Design		
Antiblooming Factor	X <sub>ab</sub>	300	-	-		Design		
Vertical Smear	Smr	-	-100	-	dB	Design		
Read Noise	n <sub>e-T</sub>	-	12	-	e <sup>-</sup> rms	Design		4
Dynamic Range	DR	-	64	-	dB	Design		4, 5
Output Amplifier DC Offset	V <sub>odc</sub>	-	9.4	-	V	Die	27, 40	
Output Amplifier Bandwidth	f <sub>-3db</sub>	-	250	-	MHz	Die		6
Output Amplifier Impedance	R <sub>OUT</sub>	-	127	-	Ohms	Die	27, 40	
Output Amplifier Sensitivity	$\Delta V/\Delta N$	-	34	-	$\mu V/e^-$	Design		

### KAI-29050-AXA and KAI-29050-PXA Configurations

Description	Symbol	Min.	Nom.	Max.	Units	Sampling Plan	Temperature Tested At (°C)	Notes
Peak Quantum Efficiency	QE <sub>max</sub>	-	46	-	%	Design		
Peak Quantum Efficiency Wavelength	λQE	-	500	-	nm	Design		

### KAI-29050-CXA and KAI-29050-PXA Configurations

Description	Symbol	Min.	Nom.	Max.	Units	Sampling Plan	Temperature Tested At (°C)	Notes
Peak Quantum Efficiency	Blue Green Red QE <sub>max</sub>	-	42 43 31	-	%	Design		
Peak Quantum Efficiency Wavelength	Blue Green Red λQE	-	470 540 620	-	nm	Design		

Notes:

1. Per color
2. Value is over the range of 10% to 90% of photodiode saturation.
3. The operating value of the substrate voltage, VAB, will be marked on the shipping container for each device. The value of VAB is set such that the photodiode charge capacity is 680 mV.
4. At 32 MHz.
5. Uses 20LOG(PNe/ n<sub>e-T</sub>)
6. Assumes 5pF load

## Typical Performance Curves

### QUANTUM EFFICIENCY

#### Monochrome with Microlens

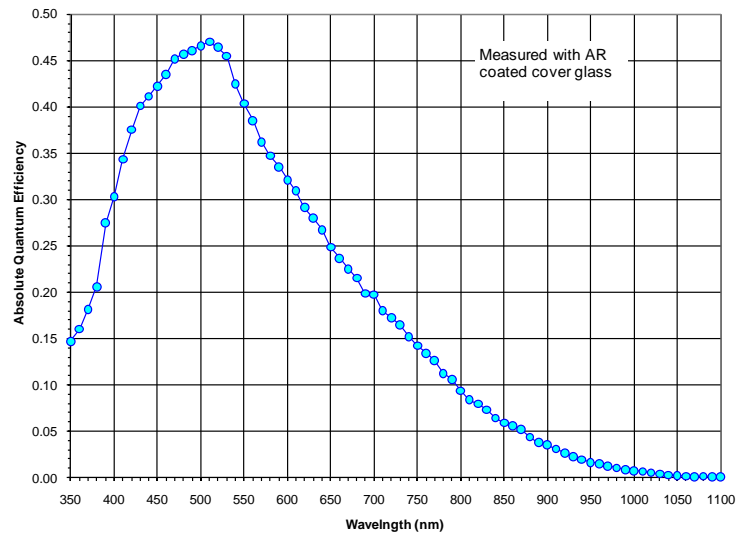

Figure 5: Monochrome with Microlens Quantum Efficiency

### Color (Bayer RGB) with Microlens

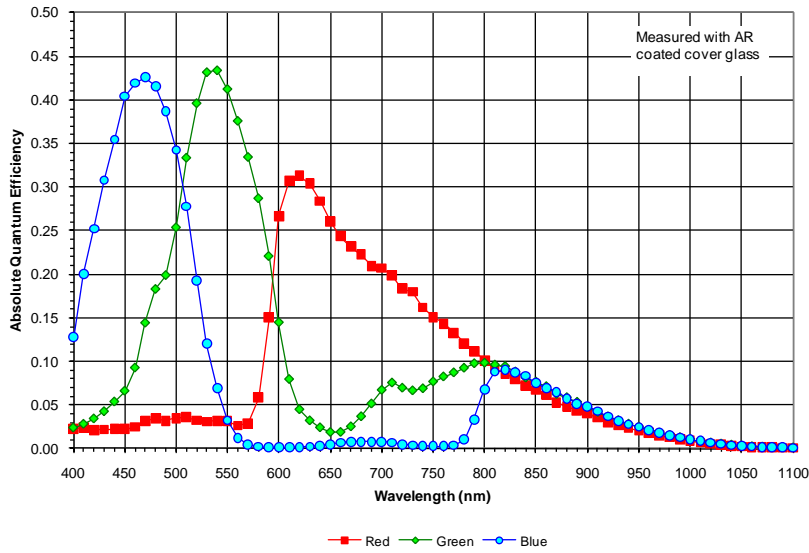

Figure 6: Color (Bayer) with Microlens Quantum Efficiency

### Color (TRUESENSE Sparse CFA) with Microlens

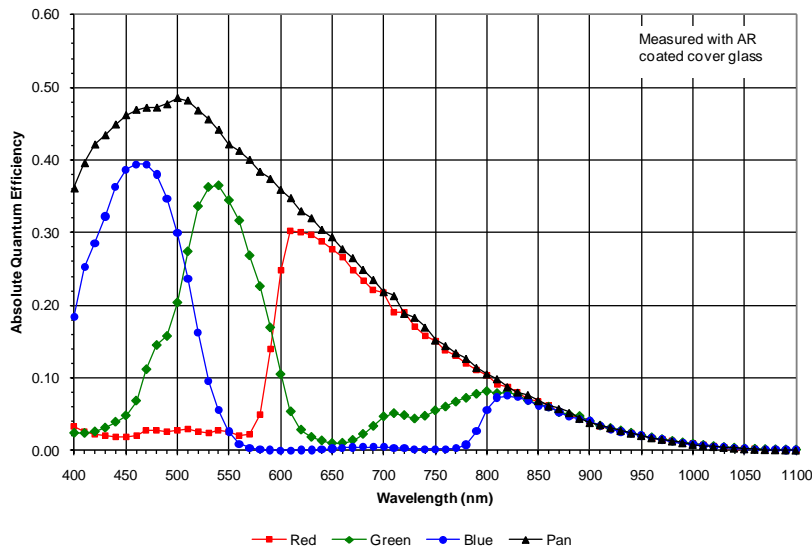

Figure 7: Color (TRUESENSE Sparse CFA) with Microlens Quantum Efficiency

## ANGULAR QUANTUM EFFICIENCY

For the curves marked "Horizontal", the incident light angle is varied in a plane parallel to the HCCD.

For the curves marked "Vertical", the incident light angle is varied in a plane parallel to the VCCD.

### Monochrome with Microlens

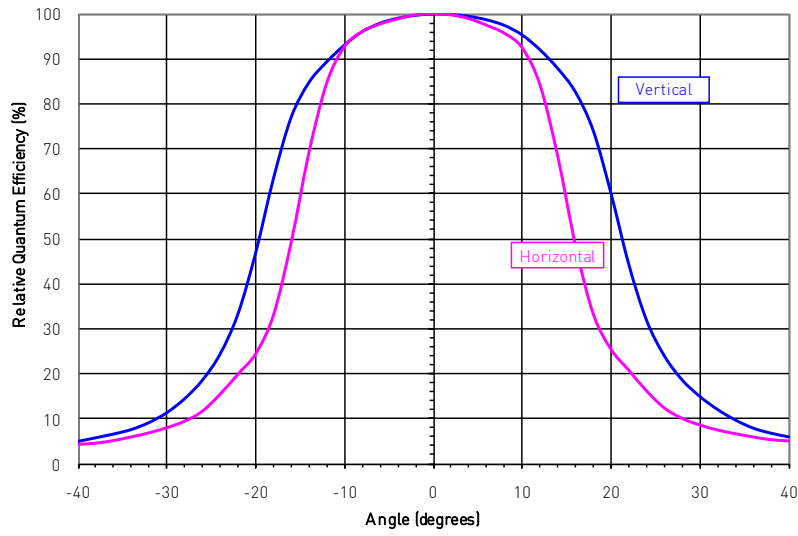

Figure 8: Monochrome with Microlens Angular Quantum Efficiency

## DARK CURRENT VERSUS TEMPERATURE

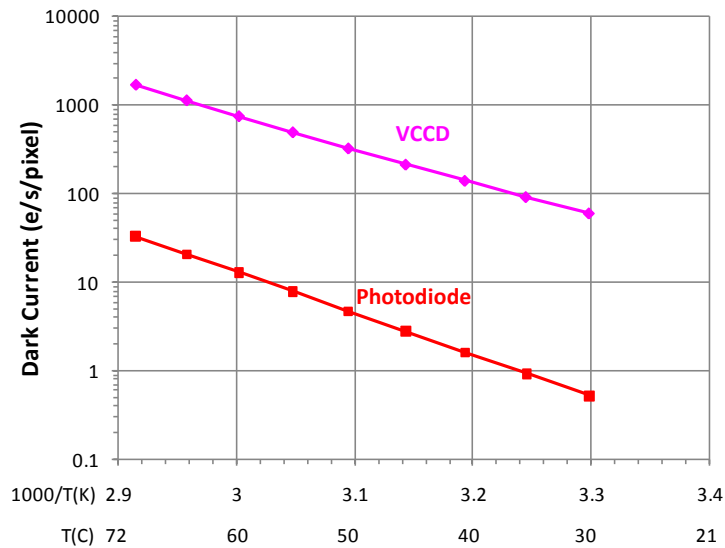

Figure 9: Dark Current versus Temperature



### POWER – ESTIMATED

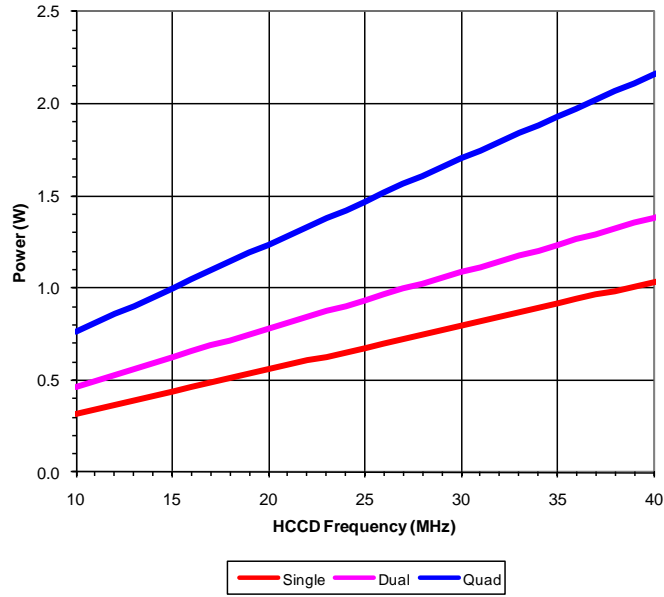

Figure 10: Power

### FRAME RATES

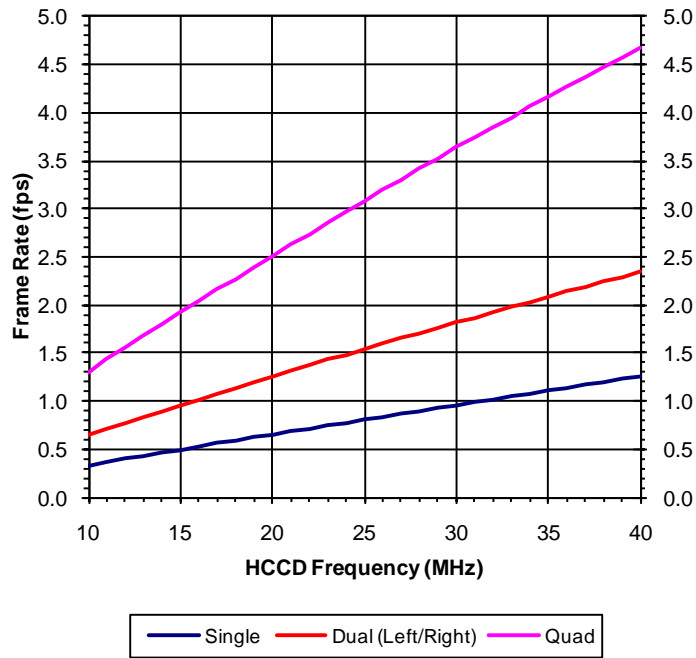

Figure 11: Frame Rates

## Defect Definitions

### OPERATION CONDITIONS FOR DEFECT TESTING AT 40 °C

Description	Condition	Notes
Operational Mode	Two outputs, using VOUTa and VOUTc, continuous readout	
HCCD Clock Frequency	10 MHz	
Pixels Per Line	6800	1
Lines Per Frame	2320	2
Line Time	715.7 μsec	
Frame Time	1660.5 msec	
Photodiode Integration Time (PD_Tint)	Mode A: PD_Tint = Frame Time = 1660.5 msec, no electronic shutter used	
VCCD Integration Time	1593.1 msec	3
Temperature	40 °C	
Light Source	Continuous red, green and blue LED illumination	4
Operation	Nominal operating voltages and timing	

Notes

1. Horizontal overclocking used
2. Vertical overclocking used
3. VCCD Integration Time = 2226 lines x Line Time, which is the total time a pixel will spend in the VCCD registers.
4. For monochrome sensor, only the green LED is used.

### DEFECT DEFINITIONS FOR TESTING AT 40 °C

Description	Definition	Grade 1	Grade 2 Mono	Grade 2 Color	Notes
Major dark field defective bright pixel	PD_Tint = Mode A → Defect ≥ 565 mV	270	540	540	1
Major bright field defective dark pixel	Defect ≥ 12%				
Minor dark field defective bright pixel	PD_Tint = Mode A → Defect ≥ 282 mV	2700	5400	5400	
Cluster Defect	A group of 2 to 19 contiguous major defective pixels, but no more than 4 adjacent defects horizontally.	20	n/a	n/a	2
Cluster Defect	A group of 2 to 38 contiguous major defective pixels, but no more than 5 adjacent defects horizontally.	n/a	50	50	2
Column defect	A group of more than 10 contiguous major defective pixels along a single column	0	7	27	2

Notes:

1. For the color devices (KAI-29050-CXA and KAI-29050-PXA), a bright field defective pixel deviates by 12% with respect to pixels of the same color.
2. Column and cluster defects are separated by no less than two (2) good pixels in any direction (excluding single pixel defects).

## OPERATION CONDITIONS FOR DEFECT TESTING AT 27 °C

Description	Condition	Notes
Operational Mode	Two outputs, using VOUTa and VOUTc, continuous readout	
HCCD Clock Frequency	10 MHz	
Pixels Per Line	6800	1
Lines Per Frame	4544	2
Line Time	715.7 $\mu$ sec	
Frame Time	3252.2 msec	
Photodiode Integration Time (PD_Tint)	Mode A: PD_Tint = Frame Time = 3252.2 msec, no electronic shutter used	
VCCD Integration Time	1593.1 msec	3
Temperature	27 °C	
Light Source	Continuous red, green and blue LED illumination	4
Operation	Nominal operating voltages and timing	

### Notes

1. Horizontal overclocking used
2. Vertical overclocking used
3. VCCD Integration Time = 2226 lines x Line Time, which is the total time a pixel will spend in the VCCD registers.
4. For monochrome sensor, only the green LED is used.

## DEFECT DEFINITIONS FOR TESTING AT 27 °C

Description	Definition	Grade 1	Grade 2 Mono	Grade 2 Color	Notes
Major dark field defective bright pixel	PD_Tint = Mode A $\rightarrow$ Defect $\geq$ 183 mV	270	540	540	1
Major bright field defective dark pixel	Defect $\geq$ 12%				
Cluster Defect	A group of 2 to 19 contiguous major defective pixels, but no more than 4 adjacent defects horizontally.	20	n/a	n/a	2
Cluster Defect	A group of 2 to 38 contiguous major defective pixels, but no more than 5 adjacent defects horizontally.	n/a	50	50	2
Column defect	A group of more than 10 contiguous major defective pixels along a single column	0	7	27	2

### Notes:

1. For the color devices (KAI-29050-CXA and KAI-29050), a bright field defective pixel deviates by 12% with respect to pixels of the same color.
2. Column and cluster defects are separated by no less than two (2) good pixels in any direction (excluding single pixel defects).

## Defect Map

The defect map supplied with each sensor is based upon testing at an ambient (27 °C) temperature. Minor point defects are not included in the defect map. All defective pixels are reference to pixel 1,1 in the defect maps. See Figure 12: Regions of Interest for the location of pixel 1,1.

## Test Definitions

### TEST REGIONS OF INTEREST

Image Area ROI: Pixel (1,1) to Pixel (6600, 4408)

Active Area ROI: Pixel (13, 13) to Pixel (6588, 4396)

Center ROI: Pixel (3251, 2155) to Pixel (3350, 2254)

Only the Active Area ROI pixels are used for performance and defect tests.

### OVERCLOCKING

The test system timing is configured such that the sensor is overclocked in both the vertical and horizontal directions. See Figure 12 for a pictorial representation of the regions of interest.

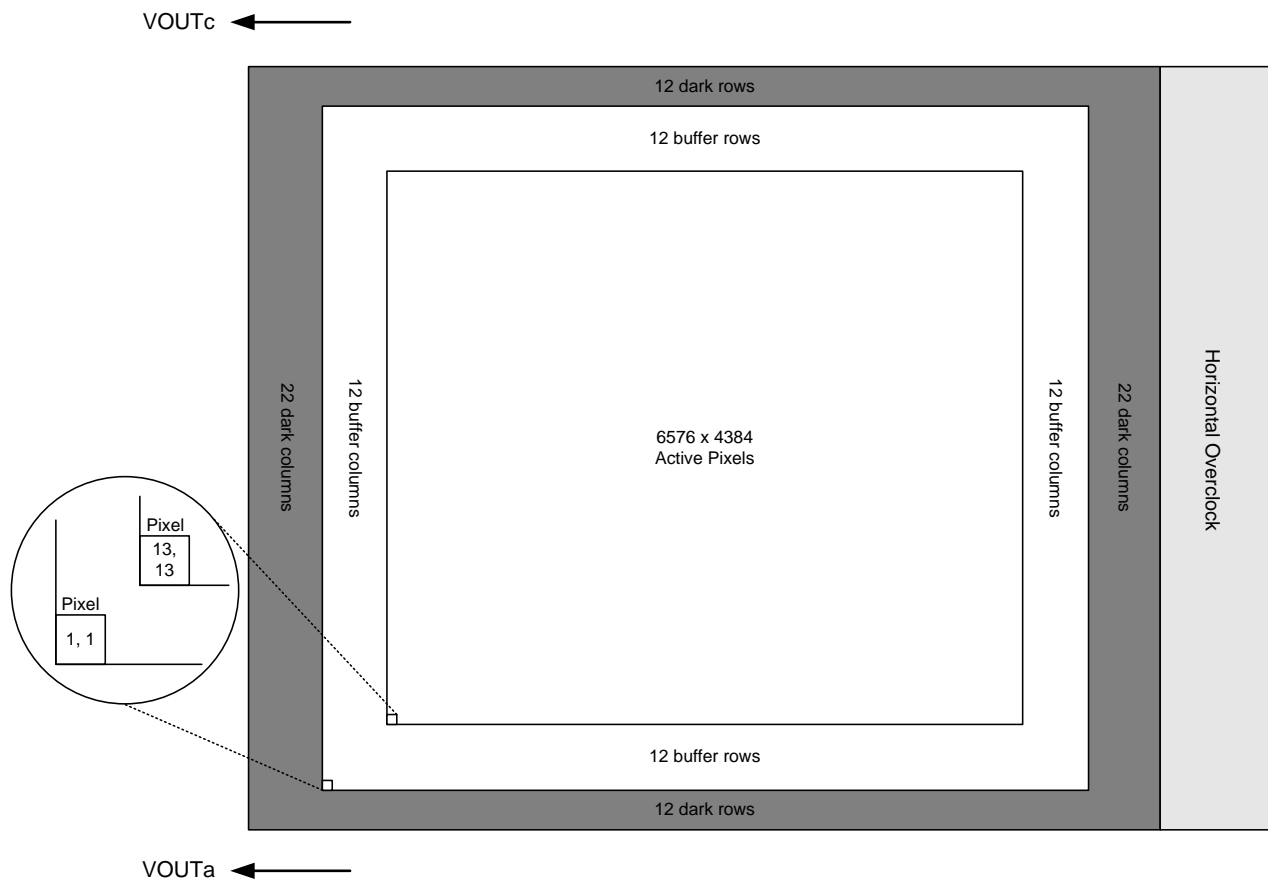

Figure 12: Regions of Interest

## TESTS

### Dark Field Global Non-Uniformity

This test is performed under dark field conditions. The sensor is partitioned into 1536 sub regions of interest, each of which is 137 by 137 pixels in size. The average signal level of each of the 1536 sub regions of interest is calculated. The signal level of each of the sub regions of interest is calculated using the following formula:

$$\text{Signal of ROI}[i] = (\text{ROI Average in counts} - \text{Horizontal overclock average in counts}) * \text{mV per count}$$

where  $i = 1$  to 1536. During this calculation on the 1536 sub regions of interest, the maximum and minimum signal levels are found. The dark field global uniformity is then calculated as the maximum signal found minus the minimum signal level found.

Units: mVpp (millivolts peak to peak)

### Global Non-Uniformity

This test is performed with the imager illuminated to a level such that the output is at 70% of saturation (approximately 476 mV). Prior to this test being performed the substrate voltage has been set such that the charge capacity of the sensor is 680 mV. Global non-uniformity is defined as

$$\text{Global Non - Uniformity} = 100 * \left( \frac{\text{Active Area Standard Deviation}}{\text{Active Area Signal}} \right)$$

Units: %rms. Active Area Signal = Active Area Average – Dark Column Average

### Global Peak to Peak Non-Uniformity

This test is performed with the imager illuminated to a level such that the output is at 70% of saturation (approximately 476 mV). Prior to this test being performed the substrate voltage has been set such that the charge capacity of the sensor is 680 mV. The sensor is partitioned into 1536 sub regions of interest, each of which is 137 by 137 pixels in size. The average signal level of each of the 1536 sub regions of interest (ROI) is calculated. The signal level of each of the sub regions of interest is calculated using the following formula:

$$\text{Signal of ROI}[i] = (\text{ROI Average in counts} - \text{Horizontal overclock average in counts}) * \text{mV per count}$$

Where  $i = 1$  to 1536. During this calculation on the 1536 sub regions of interest, the maximum and minimum signal levels are found. The global peak to peak uniformity is then calculated as:

$$\text{Global Uniformity} = 100 * \frac{\text{Maximum Signal} - \text{Minimum Signal}}{\text{Active Area Signal}}$$

Units: %pp

## Center Non-Uniformity

This test is performed with the imager illuminated to a level such that the output is at 70% of saturation (approximately 476 mV). Prior to this test being performed the substrate voltage has been set such that the charge capacity of the sensor is 680 mV. Defects are excluded for the calculation of this test. This test is performed on the center 100 by 100 pixels of the sensor. Center uniformity is defined as:

$$\text{Center ROI Uniformity} = 100 * \left( \frac{\text{Center ROI Standard Deviation}}{\text{Center ROI Signal}} \right)$$

Units: %rms. Center ROI Signal = Center ROI Average – Dark Column Average

## Dark field Defect Test

This test is performed under dark field conditions. The sensor is partitioned into 1536 sub regions of interest, each of which is 137 by 137 pixels in size. In each region of interest, the median value of all pixels is found. For each region of interest, a pixel is marked defective if it is greater than or equal to the median value of that region of interest plus the defect threshold specified in the “Defect Definitions” section.

## Bright field Defect Test

This test is performed with the imager illuminated to a level such that the output is at approximately 476 mV. Prior to this test being performed the substrate voltage has been set such that the charge capacity of the sensor is 680 mV. The average signal level of all active pixels is found. The bright and dark thresholds are set as:

$$\text{Dark defect threshold} = \text{Active Area Signal} * \text{threshold}$$

The sensor is then partitioned into 1536 sub regions of interest, each of which is 137 by 137 pixels in size. In each region of interest, the average value of all pixels is found. For each region of interest, a pixel is marked defective if it is greater than or equal to the median value of that region of interest plus the bright threshold specified or if it is less than or equal to the median value of that region of interest minus the dark threshold specified.

Example for major bright field defective pixels:

- Average value of all active pixels is found to be 476 mV
- Dark defect threshold: 476 mV \* 12 % = 57 mV
- Region of interest #1 selected. This region of interest is pixels 13, 13 to pixels 149, 149.
  - Median of this region of interest is found to be 470 mV.
  - Any pixel in this region of interest that is  $\leq (470 - 57 \text{ mV})$  413 mV in intensity will be marked defective.

All remaining 1536 sub regions of interest are analyzed for defective pixels in the same manner.

## Operation

### ABSOLUTE MAXIMUM RATINGS

Absolute maximum rating is defined as a level or condition that should not be exceeded at any time per the description. If the level or the condition is exceeded, the device will be degraded and may be damaged. Operation at these values will reduce MTTF.

Description	Symbol	Minimum	Maximum	Units	Notes
Operating Temperature	T <sub>OP</sub>	-50	+70	°C	1
Humidity	RH	+5	+90	%	2
Output Bias Current	I <sub>out</sub>	-	60	mA	3
Off-chip Load	C <sub>L</sub>	-	10	pF	

Notes:

- Noise performance will degrade at higher temperatures.
- T=25 °C. Excessive humidity will degrade MTTF.
- Total for all outputs. Maximum current is -15 mA for each output. Avoid shorting output pins to ground or any low impedance source during operation. Amplifier bandwidth increases at higher current and lower load capacitance at the expense of reduced gain (sensitivity).

### ABSOLUTE MAXIMUM VOLTAGE RATINGS BETWEEN PINS AND GROUND

Description	Minimum	Maximum	Units	Notes
VDDa, VOUTa, RDa	-0.4	17.5	V	1
V1B, V1T	ESD - 0.4	ESD + 24.0	V	
V2B, V2T, V3B, V3T, V4B, V4T	ESD - 0.4	ESD + 14.0	V	
FDGAb, FDGcd	ESD - 0.4	ESD + 14.0		
H1Sa, H1Ba, H2Sa, H2Ba, H2SLa, Ra, OGa	ESD - 0.4	ESD + 14.0	V	1
ESD	-10.0	0.0	V	
SUB	-0.4	+40.0	V	2

Notes:

- a denotes a, b, c or d
- Refer to Application Note *Using Interline CCD Image Sensors in High Intensity Visible Lighting Conditions*

## POWER UP AND POWER DOWN SEQUENCE

Adherence to the power-up and power-down sequence is critical. Failure to follow the proper power-up and power-down sequences may cause damage to the sensor.

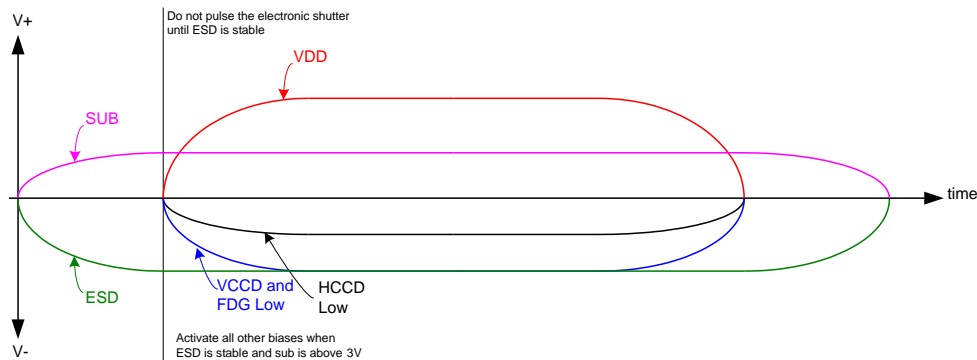
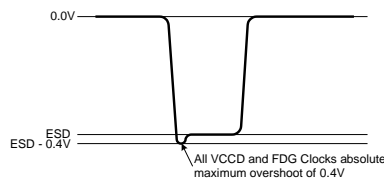

Figure 13: Power Up and Power Down Sequence

**Notes:**

1. Activate all other biases when ESD is stable and SUB is above 3V
2. Do not pulse the electronic shutter until ESD is stable
3. VDD cannot be +15V when SUB is 0V
4. The image sensor can be protected from an accidental improper ESD voltage by current limiting the SUB current to less than 10mA. SUB and VDD must always be greater than GND. ESD must always be less than GND. Placing diodes between SUB, VDD, ESD and ground will protect the sensor from accidental overshoots of SUB, VDD and ESD during power on and power off. See the figure below.

The VCCD clock waveform must not have a negative overshoot more than 0.4V below the ESD voltage.



Example of external diode protection for SUB, VDD and ESD. a denotes a, b, c or d

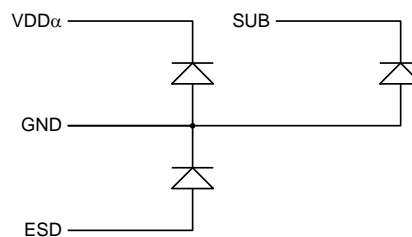



## DC BIAS OPERATING CONDITIONS

Description	Pins	Symbol	Minimum	Nominal	Maximum	Units	Maximum DC Current	Notes
Reset Drain	RD $\alpha$	RD	+11.8	+12.0	+12.2	V	10 $\mu$ A	1
Output Gate	OG $\alpha$	OG	-2.2	-2.0	-1.8	V	10 $\mu$ A	1
Output Amplifier Supply	VDD $\alpha$	VDD	+14.5	+15.0	+15.5	V	11.0 mA	1, 2
Ground	GND	GND	0.0	0.0	0.0	V	-1.0 mA	
Substrate	SUB	VSUB	+5.0	VAB	VDD	V	50 $\mu$ A	3, 8
ESD Protection Disable	ESD	ESD	-9.5	-9.0	-8.8	V	50 $\mu$ A	6, 7
Output Bias Current	VOUT $\alpha$	Iout	-3.0	-7.0	-10.0	mA	—	1, 4, 5

### Notes:

1.  $\alpha$  denotes a, b, c or d
2. The maximum DC current is for one output.  $I_{dd} = I_{out} + I_{ss}$ . See Figure 14.
3. The operating value of the substrate voltage, VAB, will be marked on the shipping container for each device. The value of VAB is set such that the photodiode charge capacity is the nominal PNE (see Specifications).
4. An output load sink must be applied to each VOUT pin to activate each output amplifier.
5. Nominal value required for 40MHz operation per output. May be reduced for slower data rates and lower noise.
6. Adherence to the power-up and power-down sequence is critical. See Power Up and Power Down Sequence section.
7. ESD maximum value must be less than or equal to V1\_L+0.4V and V2\_L+0.4V
8. Refer to Application Note *Using Interline CCD Image Sensors in High Intensity Visible Lighting Conditions*

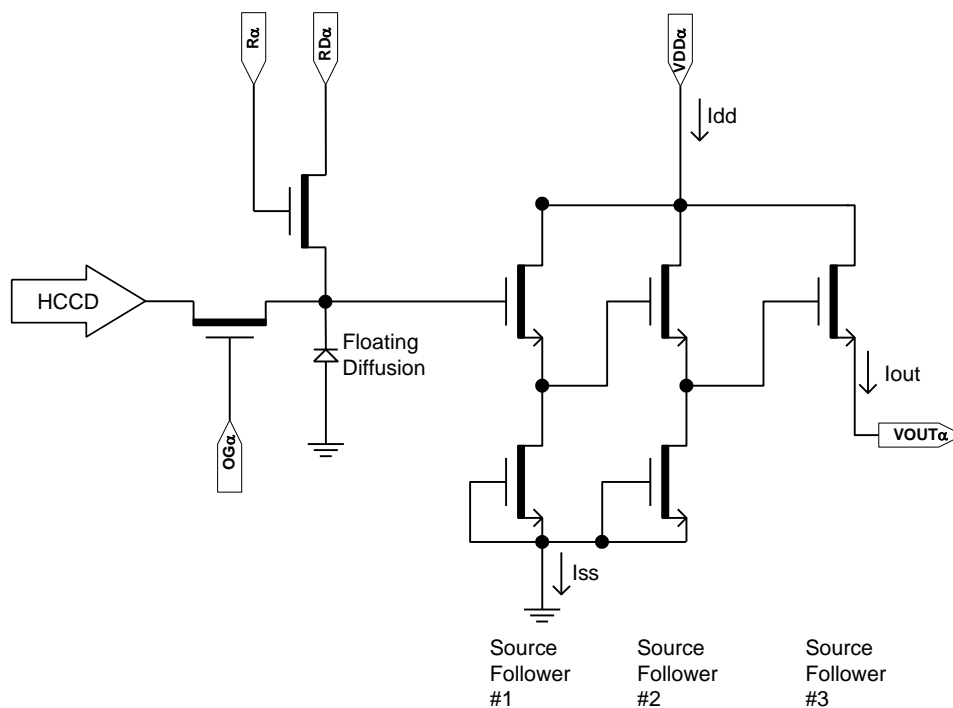

Figure 14: Output Amplifier

## AC OPERATING CONDITIONS

### Clock Levels

Description	Pins <sup>1</sup>	Symbol	Level	Minimum	Nominal	Maximum	Units	Capacitance <sup>2</sup>
Vertical CCD Clock, Phase 1	V1B, V1T	V1_L	Low	-9.5	-9.0	-8.5	V	180nF (6)
		V1_M	Mid	-0.2	+0.0	+0.2		
		V1_H	High	+12.8	+13.0	+14.0		
Vertical CCD Clock, Phase 2	V2B, V2T	V2_L	Low	-9.5	-9.0	-8.5	V	180nF (6)
		V2_H	High	-0.2	+0.0	+0.2		
Vertical CCD Clock, Phase 3	V3B, V3T	V3_L	Low	-9.5	-9.0	-8.5	V	180nF (6)
		V3_H	High	-0.2	+0.0	+0.2		
Vertical CCD Clock, Phase 4	V4B, V4T	V4_L	Low	-9.5	-9.0	-8.5	V	180nF (6)
		V4_H	High	-0.2	+0.0	+0.2		
Horizontal CCD Clock, Phase 1 Storage	H1Sa	H1S_L	Low	-5.0 (7)	-4.4	-4.2	V	600pF (6)
		H1S_A	Amplitude	+4.2	+4.4	+5.0 (7)		
Horizontal CCD Clock, Phase 1 Barrier	H1Ba	H1B_L	Low	-5.0 (7)	-4.4	-4.2	V	400pF (6)
		H1B_A	Amplitude	+4.2	+4.4	+5.0 (7)		
Horizontal CCD Clock, Phase 2 Storage	H2Sa	H2S_L	Low	-5.0 (7)	-4.4	-4.2	V	580pF (6)
		H2S_A	Amplitude	+4.2	+4.4	+5.0 (7)		
Horizontal CCD Clock, Phase 2 Barrier	H2Ba	H2B_L	Low	-5.0 (7)	-4.4	-4.2	V	400pF (6)
		H2B_A	Amplitude	+4.2	+4.4	+5.0 (7)		
Horizontal CCD Clock, Last Phase <sup>3</sup>	H2SLa	H2SL_L	Low	-5.2	-5.0	-4.8	V	20pF (6)
		H2SL_A	Amplitude	+4.8	+5.0	+5.2		
Reset Gate	Ra	R_L4	Low	-3.5	-2.0	-1.5	V	16pF (6)
		R_H	High	+2.5	+3.0	+4.0		
Electronic Shutter <sup>5</sup>	SUB	VES	High	+29.0	+30.0	+40.0	V	12nF (6)
Fast Line Dump Gate	FDGa	FDG_L	Low	-9.5	-9.0	-8.5	V	50pF (6)
		FDG_H	High	+4.5	+5.0	+5.5		

#### Notes:

1. a denotes a, b, c or d
2. Capacitance is total for all like named pins
3. Use separate clock driver for improved speed performance.
4. Reset low should be set to -3 volts for signal levels greater than 40,000 electrons.
5. Refer to Application Note *Using Interline CCD Image Sensors in High Intensity Visible Lighting Conditions*
6. Capacitance values are estimated
7. If the minimum horizontal clock low level is used (-5.0V), then the maximum horizontal clock amplitude should be used (5V amplitude) to create a -5.0V to 0.0V clock

The figure below shows the DC bias (VSUB) and AC clock (VES) applied to the SUB pin. Both the DC bias and AC clock are referenced to ground.

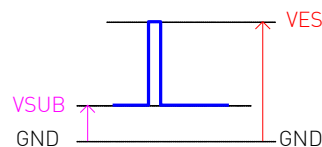

## DEVICE IDENTIFICATION

The device identification pin (DevID) may be used to determine which Truesense Imaging 5.5 micron pixel interline CCD sensor is being used.

Description	Pins	Symbol	Minimum	Nominal	Maximum	Units	Maximum DC Current	Notes
Device Identification	DevID	DevID	200,000	300,000	400,000	Ohms	50 $\mu$ A	1, 2, 3

Notes:

1. Nominal value subject to verification and/or change during release of preliminary specifications.
2. If the Device Identification is not used, it may be left disconnected.
3. After Device Identification resistance has been read during camera initialization, it is recommended that the circuit be disabled to prevent localized heating of the sensor due to current flow through the R\_DeviceID resistor.

## Recommended Circuit

Note that V1 must be a different value than V2.

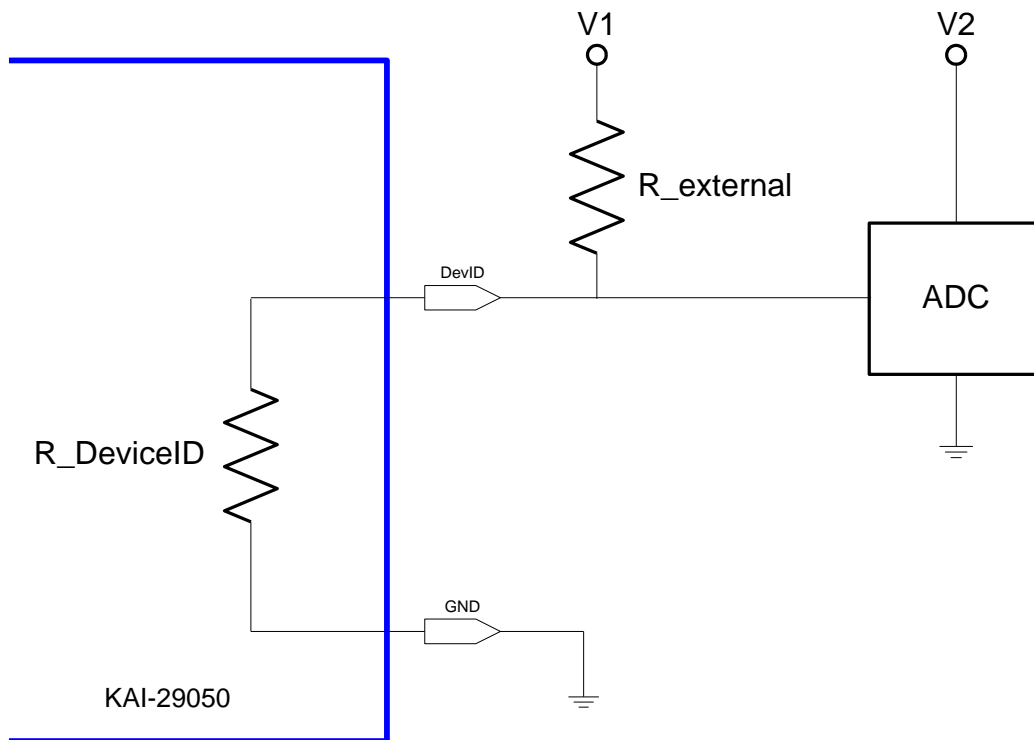

Figure 15: Device Identification Recommended Circuit

## Timing

### REQUIREMENTS AND CHARACTERISTICS

Description	Symbol	Minimum	Nominal	Maximum	Units	Notes
Photodiode Transfer	$t_{pd}$	6	-	-	$\mu\text{s}$	
VCCD Leading Pedestal	$t_{3p}$	16	-	-	$\mu\text{s}$	
VCCD Trailing Pedestal	$t_{3d}$	16	-	-	$\mu\text{s}$	
VCCD Transfer Delay	$t_d$	4	-	-	$\mu\text{s}$	
VCCD Transfer	$t_v$	8	-	-	$\mu\text{s}$	
VCCD Clock Cross-over	$V_{VCR}$	75	-	100	%	1
VCCD Rise, Fall Times	$t_{VR}, t_{VF}$	5	-	10	%	1, 2
FDG Delay	$t_{fdg}$	2	-	-	$\mu\text{s}$	
HCCD Delay	$t_{hs}$	1	-	-	$\mu\text{s}$	
HCCD Transfer	$t_e$	25.0	29.4	-	ns	
Shutter Transfer	$t_{sub}$	1	-	-	$\mu\text{s}$	
Shutter Delay	$t_{hd}$	1	-	-	$\mu\text{s}$	
Reset Pulse	$t_r$	2.5	-	-	ns	
Reset – Video Delay	$t_{rv}$	-	2.2	-	ns	
H2SL – Video Delay	$t_{hv}$	-	3.1	-	ns	
Line Time	$t_{line}$	96.3	110.0	-	$\mu\text{s}$	Dual HCCD Readout
		179.4	208.7	-		Single HCCD Readout
Frame Time	$t_{frame}$	213.5	246.1	-	ms	Quad HCCD Readout
		427.0	492.2	-		Dual HCCD Readout
		795.1	925.2	-		Single HCCD Readout

#### Notes:

1. Refer to Figure 20: VCCD Clock Rise Time, Fall Time and Edge Alignment
2. Relative to the pulse width
3. Refer to timing diagrams as shown in Figure 16, Figure 17, Figure 18, Figure 19 and Figure 20

## TIMING DIAGRAMS

The timing sequence for the clocked device pins may be represented as one of seven patterns (P1-P7) as shown in the table below. The patterns are defined in Figure 16 and Figure 17. Contact Truesense Imaging Application Engineering for other readout modes.

Device Pin	Quad Readout	Dual Readout VOUTa, VOUTb	Dual Readout VOUTa, VOUTc	Single Readout VOUTa
V1T	P1T	P1B	P1T	P1B
V2T	P2T	P4B	P2T	P4B
V3T	P3T	P3B	P3T	P3B
V4T	P4T	P2B	P4T	P2B
V1B	P1B			
V2B	P2B			
V3B	P3B			
V4B	P4B			
H1Sa	P5			
H1Ba	P5			
H2Sa <sup>2</sup>	P6			
H2Ba	P6			
Ra	P7			
H1Sb	P5		P5	
H1Bb	P5		P6	
H2Sb <sup>2</sup>	P6		P6	
H2Bb	P6		P5	
Rb	P7		P7 <sup>1</sup> or Off <sup>3</sup>	
H1Sc	P5	P5 <sup>1</sup> or Off <sup>3</sup>	P5	P5 <sup>1</sup> or Off <sup>3</sup>
H1Bc	P5	P5 <sup>1</sup> or Off <sup>3</sup>	P5	P5 <sup>1</sup> or Off <sup>3</sup>
H2Sc <sup>2</sup>	P6	P6 <sup>1</sup> or Off <sup>3</sup>	P6	P6 <sup>1</sup> or Off <sup>3</sup>
H2Bc	P6	P6 <sup>1</sup> or Off <sup>3</sup>	P6	P6 <sup>1</sup> or Off <sup>3</sup>
Rc	P7	P7 <sup>1</sup> or Off <sup>3</sup>	P7	P7 <sup>1</sup> or Off <sup>3</sup>
H1Sd	P5	P5 <sup>1</sup> or Off <sup>3</sup>	P5	P5 <sup>1</sup> or Off <sup>3</sup>
H1Bd	P5	P5 <sup>1</sup> or Off <sup>3</sup>	P6	P5 <sup>1</sup> or Off <sup>3</sup>
H2Sd <sup>2</sup>	P6	P6 <sup>1</sup> or Off <sup>3</sup>	P6	P6 <sup>1</sup> or Off <sup>3</sup>
H2Bd	P6	P6 <sup>1</sup> or Off <sup>3</sup>	P5	P6 <sup>1</sup> or Off <sup>3</sup>
Rd	P7	P7 <sup>1</sup> or Off <sup>3</sup>	P7 <sup>1</sup> or Off <sup>3</sup>	P7 <sup>1</sup> or Off <sup>3</sup>
# Lines/Frame (Minimum)	2226	4452	2226	4452
# Pixels/Line (Minimum)	3333		6666	

**Notes:**

1. For optimal performance of the sensor. May be clocked at a lower frequency. If clocked at a lower frequency, the frequency selected should be a multiple of the frequency used on the a and b register.
2. H2SLx follows the same pattern as H2Sx For optimal speed performance, use a separate clock driver.
3. Off = +5V. Note that there may be operating conditions (high temperature and/or very bright light sources) that will cause blooming from the unused c/d register into the image area.

### Photodiode Transfer Timing

A row of charge is transferred to the HCCD on the falling edge of V1 as indicated in the P1 pattern below. Using this timing sequence, the leading dummy row or line is combined with the first dark row in the HCCD. The “Last Line” is dependent on readout mode – either 2226 or 4452 minimum counts required. It is important to note that, in general, the rising edge of a vertical clock (patterns P1-P4) should be coincident or slightly leading a falling edge at the same time interval. This is particularly true at the point where P1 returns from the high (3<sup>rd</sup> level) state to the mid state when P4 transitions from the low state to the high state.

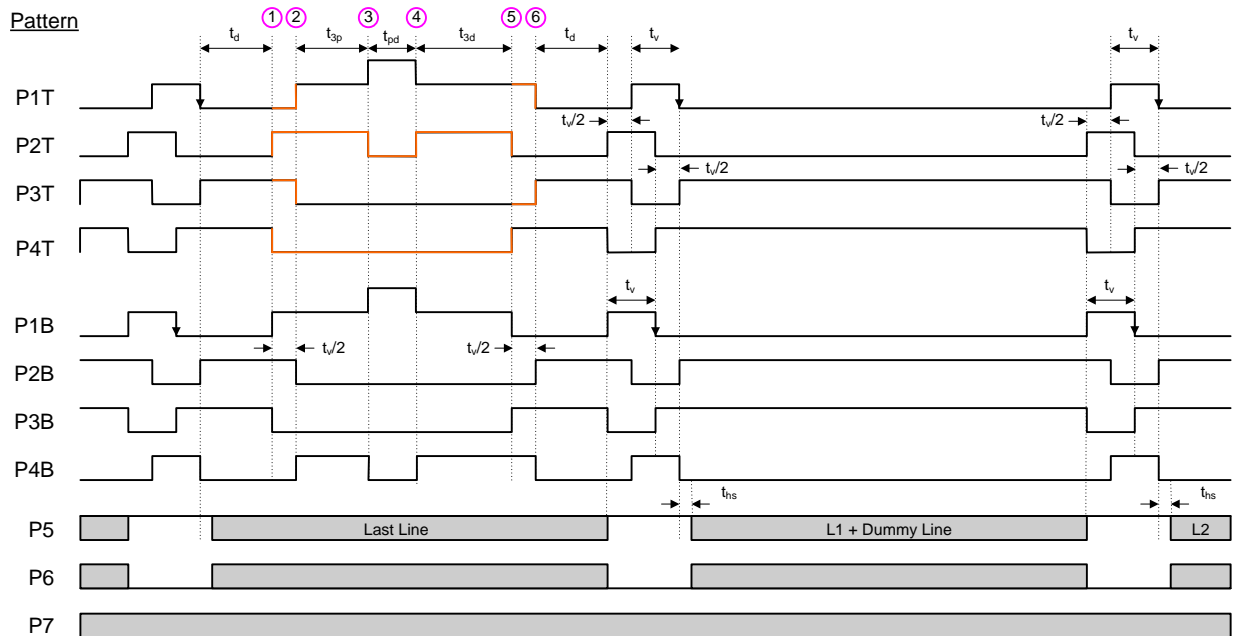

Figure 16: Photodiode Transfer Timing

### Line and Pixel Timing

Each row of charge is transferred to the output, as illustrated below, on the falling edge of H2SL (indicated as P6 pattern). The number of pixels in a row is dependent on readout mode – either 3333 or 6666 minimum counts required.

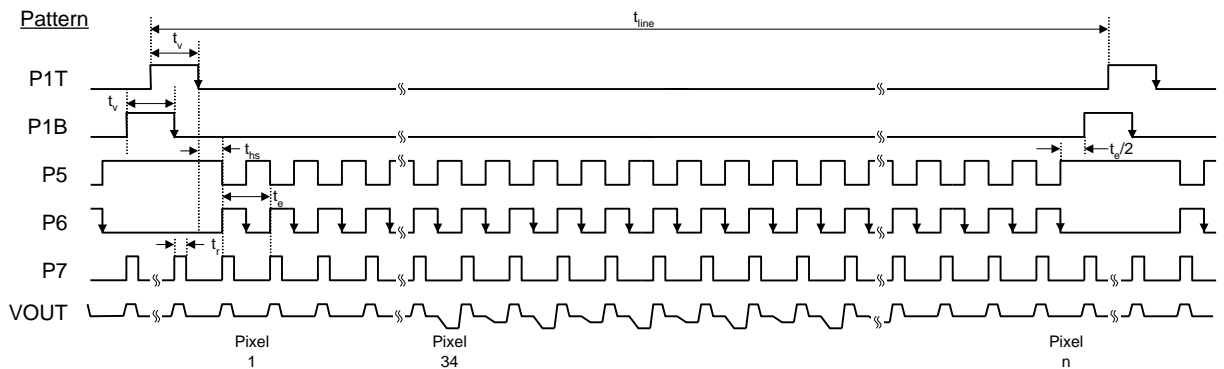

Figure 17: Line and Pixel Timing

### Pixel Timing Detail

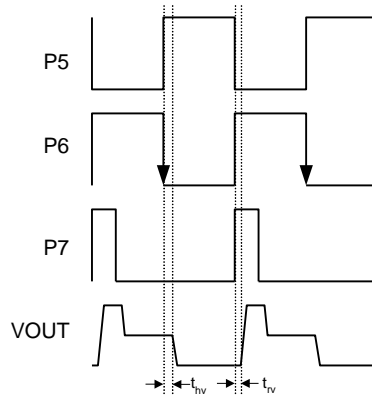

Figure 18: Pixel Timing Detail

### Frame/Electronic Shutter Timing

The SUB pin may be optionally clocked to provide electronic shuttering capability as shown below. The resulting photodiode integration time is defined from the falling edge of SUB to the falling edge of V1 (P1 pattern).

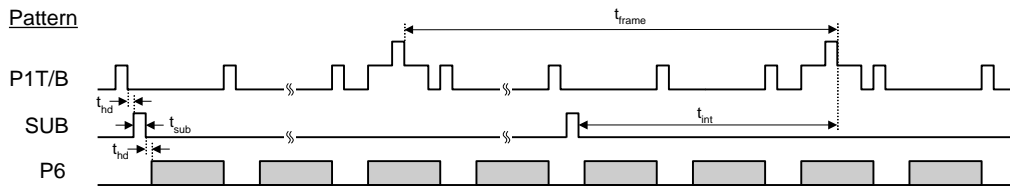

Figure 19: Frame/Electronic Shutter Timing

### VCCD Clock Edge Alignment

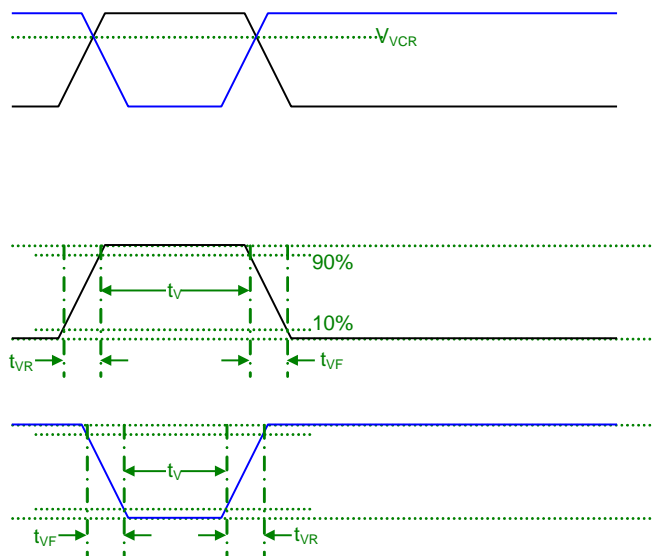

Figure 20: VCCD Clock Rise Time, Fall Time and Edge Alignment

### Line and Pixel Timing – Vertical Binning by 2

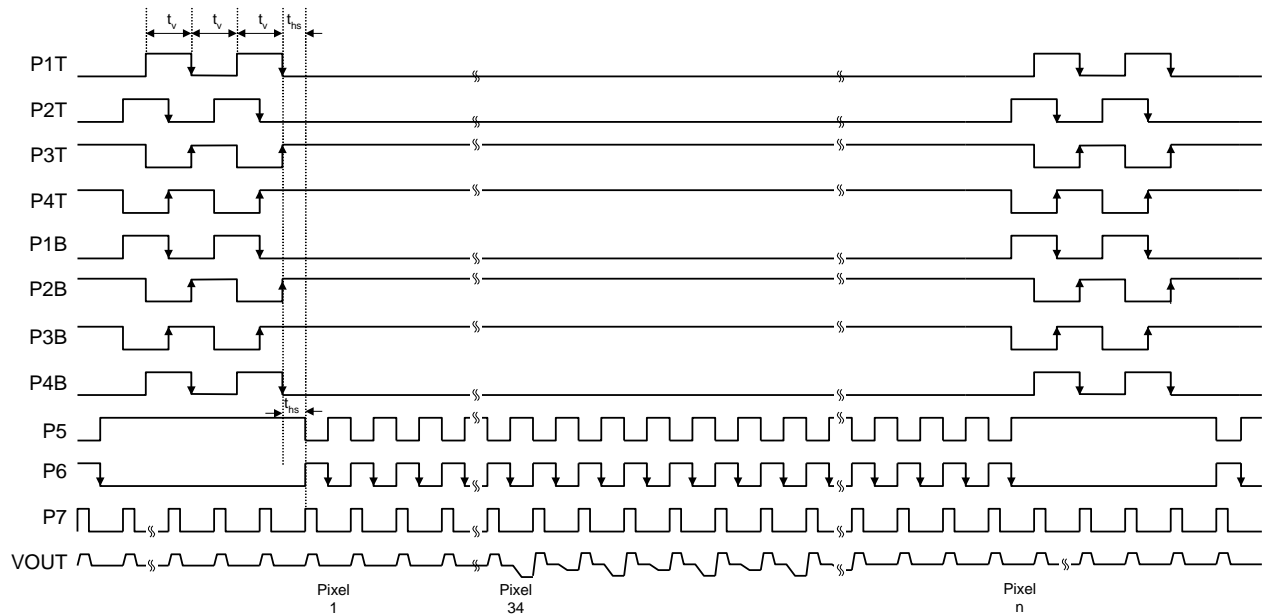

Figure 21: Line and Pixel Timing - Vertical Binning by 2

### Fast Line Dump Timing

The FDG pins may be optionally clocked to efficiently remove unwanted lines in the image resulting for increased frame rates at the expense of resolution. Below is an example of a 2 line dump sequence followed by a normal readout line. Note that the FDG timing transitions should complete prior to the beginning of V1 timing transitions as illustrated below.

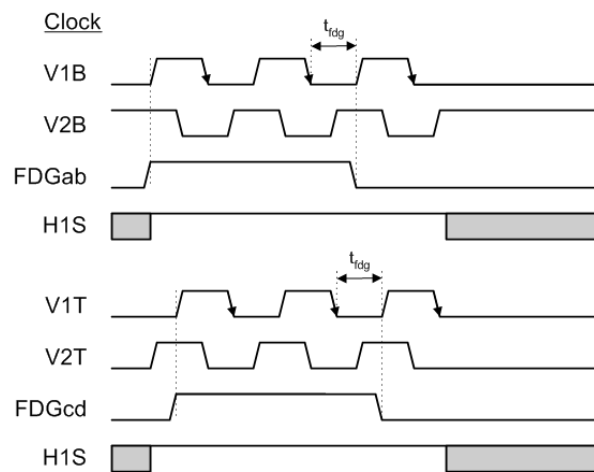

Figure 22: Fast Line Dump Timing



## Storage and Handling

### STORAGE CONDITIONS

Description	Symbol	Minimum	Maximum	Units	Notes
Storage Temperature	T <sub>ST</sub>	-55	+80	°C	1
Humidity	RH	5	90	%	2

#### Notes:

1. Long-term storage toward the maximum temperature will accelerate color filter degradation.
2. T=25 °C. Excessive humidity will degrade MTF.

### ESD

1. This device contains limited protection against Electrostatic Discharge (ESD). ESD events may cause irreparable damage to a CCD image sensor either immediately or well after the ESD event occurred. Failure to protect the sensor from electrostatic discharge may affect device performance and reliability.
2. Devices should be handled in accordance with strict ESD procedures for Class 0 (<250V per JESD22 Human Body Model test), or Class A (<200V JESD22 Machine Model test) devices. Devices are shipped in static-safe containers and should only be handled at static-safe workstations.
3. See Application Note *Image Sensor Handling Best Practices* for proper handling and grounding procedures. This application note also contains workplace recommendations to minimize electrostatic discharge.
4. Store devices in containers made of electro-conductive materials.

### COVER GLASS CARE AND CLEANLINESS

1. The cover glass is highly susceptible to particles and other contamination. Perform all assembly operations in a clean environment.
2. Touching the cover glass must be avoided.
3. Improper cleaning of the cover glass may damage these devices. Refer to Application Note *Image Sensor Handling Best Practices*.

### ENVIRONMENTAL EXPOSURE

1. Extremely bright light can potentially harm CCD image sensors. Do not expose to strong sunlight for long periods of time, as the color filters and/or microlenses may become discolored. In addition, long time exposures to a static high contrast scene should be avoided. Localized changes in response may occur from color filter/microlens aging. For Interline devices, refer to Application Note *Using Interline CCD Image Sensors in High Intensity Visible lighting Conditions*.
2. Exposure to temperatures exceeding maximum specified levels should be avoided for storage and operation, as device performance and reliability may be affected.
3. Avoid sudden temperature changes.
4. Exposure to excessive humidity may affect device characteristics and may alter device performance and reliability, and therefore should be avoided.
5. Avoid storage of the product in the presence of dust or corrosive agents or gases, as deterioration of lead solderability may occur. It is advised that the solderability of the device leads be assessed after an extended period of storage, over one year.

### SOLDERING RECOMMENDATIONS

1. The soldering iron tip temperature is not to exceed 370 °C. Higher temperatures may alter device performance and reliability.
2. Flow soldering method is not recommended. Solder dipping can cause damage to the glass and harm the imaging capability of the device. Recommended method is by partial heating using a grounded 30W soldering iron. Heat each pin for less than 2 seconds duration.

## Mechanical Information

### COMPLETED ASSEMBLY

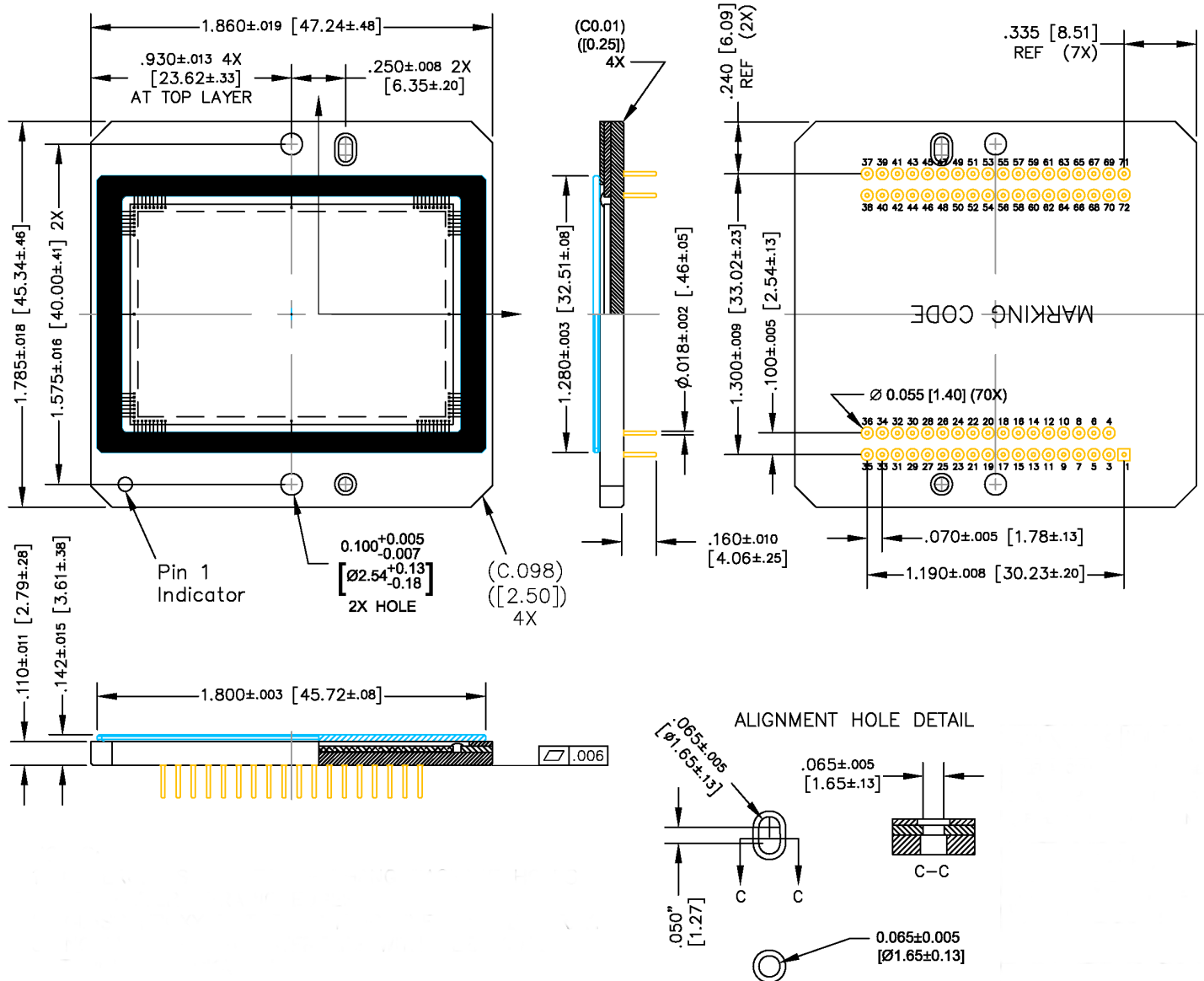

Figure 23: Completed Assembly (1 of 2)

Notes:

1. See Ordering Information for marking code.
2. Cover glass not to overhang package holes or outer ceramic edges
3. Glass epoxy not to extend over image array
4. No materials to interfere with clearance through package holes.
5. Units: IN [MM]

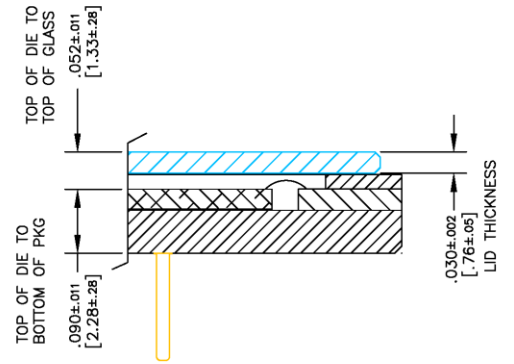
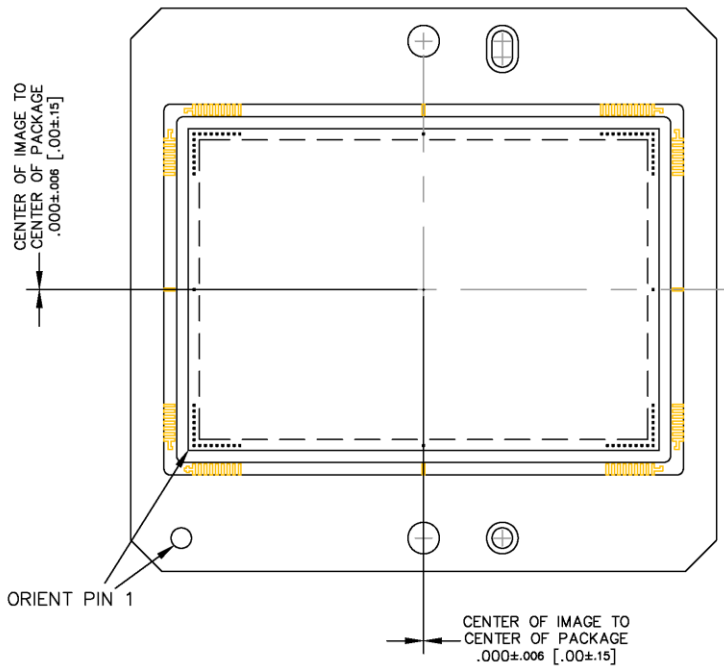

Figure 24: Completed Assembly (2 of 2)

Notes:

1. Units IN [MM]

## COVER GLASS

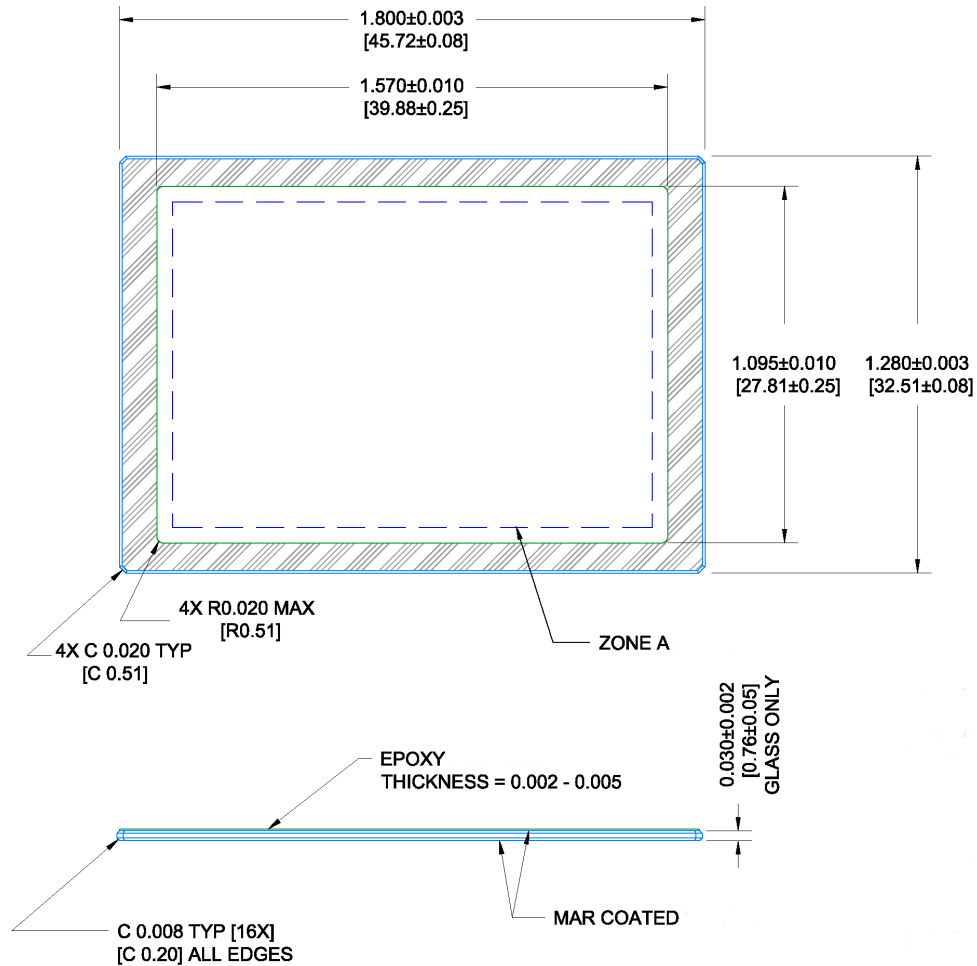

Figure 25: Cover Glass

### Notes:

1. Substrate = Schott D263T eco
2. Dust, Scratch, Inclusion Specification:
  - a. 20  $\mu$ m Max size in Zone A
  - b. Zone A = 1.474 x 1.000 [16.43 x 10.08] Centered
3. MAR coated both sides
4. Spectral Transmission
  - a. 350 – 365 nm: T  $\geq$  88%
  - b. 365 – 405 nm: T  $\geq$  94%
  - c. 405 – 450 nm: T  $\geq$  98%
  - d. 450 – 650 nm: T  $\geq$  99%
  - e. 650 – 690 nm: T  $\geq$  98%
  - f. 690 – 770 nm: T  $\geq$  94%
  - g. 770 – 870 nm: T  $\geq$  88%
5. Units: IN [MM]

## COVER GLASS TRANSMISSION

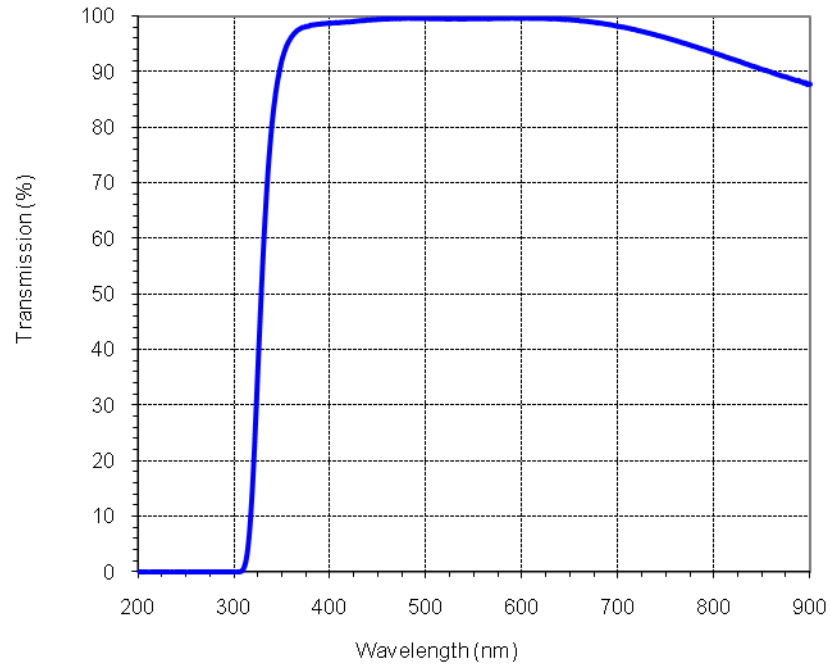

Figure 26: Cover Glass Transmission

## Quality Assurance and Reliability

### QUALITY AND RELIABILITY

All image sensors conform to the specifications stated in this document. This is accomplished through a combination of statistical process control and visual inspection and electrical testing at key points of the manufacturing process, using industry standard methods. Information concerning the quality assurance and reliability testing procedures and results are available from Truesense Imaging upon request. For further information refer to Application Note *Quality and Reliability*.

### REPLACEMENT

All devices are warranted against failure in accordance with the *Terms of Sale*. Devices that fail due to mechanical and electrical damage caused by the customer will not be replaced.

### LIABILITY OF THE SUPPLIER

A reject is defined as an image sensor that does not meet all of the specifications in this document upon receipt by the customer. Product liability is limited to the cost of the defective item, as defined in the *Terms of Sale*.

### LIABILITY OF THE CUSTOMER

Damage from mishandling (scratches or breakage), electrostatic discharge (ESD), or other electrical misuse of the device beyond the stated operating or storage limits, which occurred after receipt of the sensor by the customer, shall be the responsibility of the customer.

### TEST DATA RETENTION

Image sensors shall have an identifying number traceable to a test data file. Test data shall be kept for a period of 2 years after date of delivery.

### MECHANICAL

The device assembly drawing is provided as a reference.

Truesense Imaging reserves the right to change any information contained herein without notice. All information furnished by Truesense Imaging is believed to be accurate.

## Life Support Applications Policy

Truesense Imaging image sensors are not authorized for and should not be used within Life Support Systems without the specific written consent of Truesense Imaging, Inc.

## Revision Changes

### MTD/PS-1196

Revision Number	Description of Changes
1.0	<ul style="list-style-type: none"><li>Initial Release</li></ul>
2.0	<ul style="list-style-type: none"><li>Updated reference documentation statement on Ordering Page</li></ul>

### PS-0008

Revision Number	Description of Changes
1.0	<ul style="list-style-type: none"><li>Initial release with new document number, updated branding and document template</li><li>Updated <i>Storage and Handling</i> and <i>Quality Assurance and Reliability</i> sections</li></ul>
2.0	<ul style="list-style-type: none"><li>Added Monochrome, Special Microlens, PGA Package, Taped Clear Cover Glass with AR coating (both sides) part numbers to the Ordering Information Table</li></ul>