

Manta

G-505



- Versatile 5 Megapixel camera
- 15 fps
- PoE optional
- Video-iris lens control

Description

Manta G-505B/C includes the Super HAD 2/3" Sony ICX625 sensor. This sensor is suitable for a wide variety of high-resolution applications such as inspection and microscopy solutions.

Options

- PoE (Power over Ethernet)
- Various IR cut/pass filters and lens mounts
- White medical housing

Specifications

Manta	G-505
Interface	IEEE 802.3 1000BASE-T, IEEE 802.3af (PoE) optional
Resolution	2452 × 2056
Sensor	Sony ICX625
Sensor type	CCD Progressive
Cell size	3.45 μm
Lens mount	C-Mount, CS-Mount
Max frame rate at full resolution	15 fps
ADC	14 bit
On-board FIFO	128 Mbyte
Non-volatile memory	1024 kB
Output	
Bit depth	8-12 bit
Mono modes	Mono8, Mono12Packed, Mono12
Color modes YUV	YUV411Packed, YUV422Packed, YUV444Packed
Color modes RGB	RGB8Packed, BGR8Packed

Manta	G-505
Raw modes	BayerRG8, BayerRG12, BayerRG12Packed
General purpose inputs/outputs (GPIOs)	
Opto-isolated I/Os	2 inputs, 2 outputs
RS-232	1
Operating conditions/dimensions	
Operating temperature	+5 °C ... +45 °C
Power requirements (DC)	PoE, or 8-30 VDC
Power consumption (@12 V)	4.5 W (PoE) / 3.9 W (non-PoE)
Mass	200 g (PoE) / 190 g (non-PoE)
Body dimensions (L × W × H in mm)	86.4 × 44 × 29 mm incl. connectors
Regulations	CE, FCC Class B, RoHS

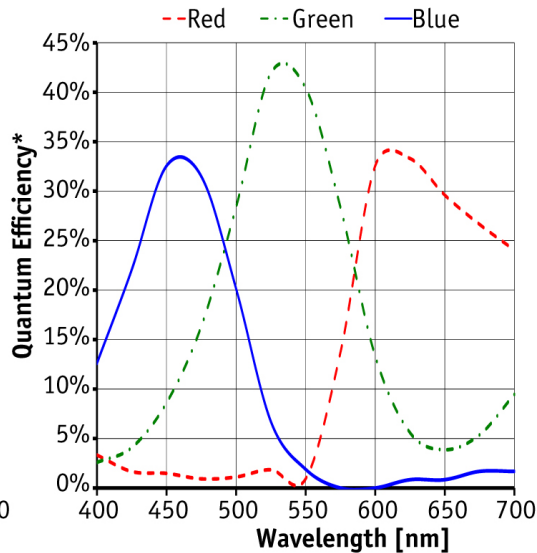
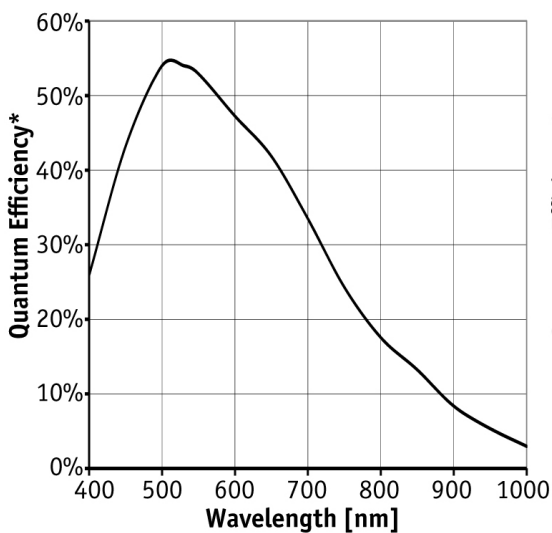

*QE measured without protection glass or filters. With glass or filters, quantum efficiency decreases by approximately 10%.

Features

- Precision Time Protocol (IEEE 1588)
- Camera temperature monitoring
- Video-type auto iris
- ROI, separate ROI for auto features
- Binning
- Decimation
- Auto gain (manual gain control: 0 to 31 dB)
- Auto exposure (49 μ s to 38 s)
- Auto white balance



- LUTs (look-up tables)
- Gamma
- Hue, saturation, color correction
- StreamBytesPerSecond (easy bandwidth control)
- Stream hold
- Sync out modes: Trigger ready, input, exposing, readout, imaging, strobe, GPO
- Event channel
- Chunk data
- Storable user sets

Technical drawing

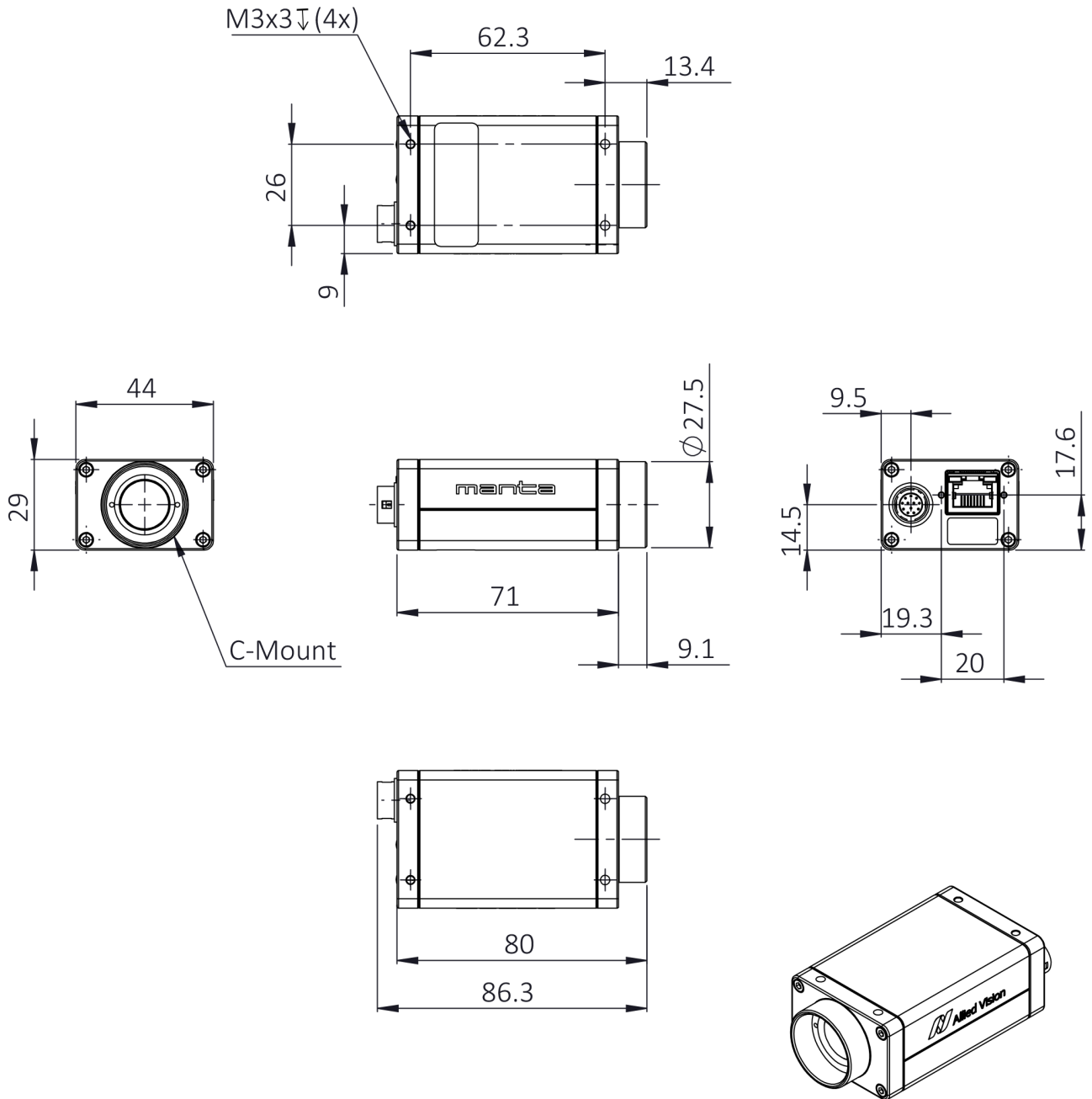



Applications

Manta G-505B/C with the ICX625 sensor is a 5 Megapixel camera for a wide range of industrial applications:

- Machine vision
- Inspection and quality control
- Microscopy
- ITS solutions
- Automation
- Logistics