

❖ **SW-4000T-CXPA**
❖ **SW-8000T-CXPA**
3-CMOS prism line scan camera

- 3 x 4096 pixels
- 3 x 8192 pixels
- 97 kHz
- 49 kHz

Sweep+ Series 

CoaXPress[®]

Preliminary Version



- Prism-based line scan camera with 3 x 4096 or 3 x 8192 pixels
- CoaXPress v2.0 standard with CXP-12 speed
- Prism technology for superior color quality and better color differentiation
- Max. line rates (RGB8/CXP-12) - SW-4000T-CXPA: 97 kHz; SW-8000T-CXPA: 49 kHz
- Pixel Size:
 - SW-4000T-CXPA: 7.5 μm x 7.5 μm or 7.5 μm x 10.5 μm
 - SW-8000T-CXPA: 3.75 μm x 5.78 μm
- Supports horizontal and vertical binning functions
- Flat field correction and color shading correction
- HSI and XYZ color space conversion
- Supports direct connection to rotary encoders plus large variety of trigger options
- Selectable Pixel Formats: RGB8, RGB10, and YUV422_8
- Excellent shock and vibration resistance
- Accepts power over CoaXPress interface
- Lens Mount: F or M52

Specifications for SW-4000T-CXPA / SW-8000T-CXPA

Sweep+ Series

Specifications	SW-4000T-CXPA/SW-8000T-CXPA
Scanning system	3 high-speed CMOS line sensors, prism-mounted
Active pixels	4000T: 3 x 4096 pixels (R, G, B) 8000T: 3 x 8192 pixels (R, G, B)
Line rate (full width)	4000T: 97 kHz (RGB8), 145 kHz (YUV422_8) 8000T: 49 kHz (RGB8), 73 kHz (YUV422_8)
Sensor width	30.72 mm
Pixel size	4000T: 7.5 μm x 7.5 μm or 7.5 μm x 10.5 μm 8000T: 3.75 μm x 5.78 μm
Interface	CoaxPress 2.0 (Micro-BNC connector) CXP-12, CXP-6, CXP-3
Video output	RGB8, RGB10, YUV422_8
Inputs (Trigger)	1 Opto In, + 2 TTL via 12-pin, 2 TTL via 10-pin, CXP In, Pulse Generator (4), Logic Block (2), User Out (4), Encoder Trigger
Outputs	2 TTL via 12-pin, 2 TTL via 10-pin
Gain (Analog Gain: only on SW-4000T-CXPA)	Analog Gain*: 0 dB / 6 dB / 12 dB Digital Master: 0 to +30 dB, R/B: -7.96 to +12 dB Digital Individual: 0 to +36 dB or -7.96 to +12 dB
White balance	Off, Once, ExposureOnce, Preset (5000K, 6500K, 7500K)
Gamma - SW-4000T-CXPA	0.45 to 1.0 (9 steps) or 257-point LUT
Gamma - SW-8000T-CXPA	0.45 to 4.0 (20 steps) or 257-point LUT
Image processing	PRNU/DSNU, black level, flat shading and color shading correction, chromatic aberration adjustment, horizontal mirroring, noise filtering
Color space conversion	RGB to HSI, XYZ (CIE), sRGB, Adobe RGB, or Color Correction Matrix
Exposure modes	Off, timed, and trigger width control
Exposure time	3 μs ~ 15.149 ms Exposure time can be longer at slower line rates.
Pulse width control	1.8 μs to ~1 sec
Lens mount	Nikon F-mount or M52 mount (46.5 mm back flange distance for both mounts)
Operating temp. (ambient)	-5°C to +45°C (20 to 80% non-condensing)
Storage temp. (ambient)	-25°C to +60°C (20 to 80% non condensing)
Vibration	3G (20 Hz to 200 Hz, XYZ directions)
Shock	50G
Regulations	CE (EN55035 and EN55032) FCC Part15 Subpart B, RoHS/WEEE, KC
Power - SW-4000T-CXPA	12-pin: +10.8V ~ +26.4V DC, 8.0W typical @ +12V, 10.0W Max PoCXP: +18.5V ~ +26V, 8.9W typical, 10.0W Max
Power - SW-8000T-CXPA	12-pin: +10.8V ~ +26.4V DC, TBD W @ +12V, TBD W Max PoCXP: +18.5V ~ +26V, TBD W typical, TBD W Max
Dimensions (H x W x L)	(without connector and lens mount protrusions) 90 mm x 90 mm x 90 mm
Weight	790 g (typical)

Ordering Information

SW-4000T-CXPA-F	3-CMOS prism line scan camera with F-mount
SW-4000T-CXPA-M52	3-CMOS prism line scan camera with M52-mount
SW-8000T-CXPA-F	3-CMOS prism line scan camera with F-mount
SW-8000T-CXPA-M52	3-CMOS prism line scan camera with M52-mount

Dimensions (F-mount)

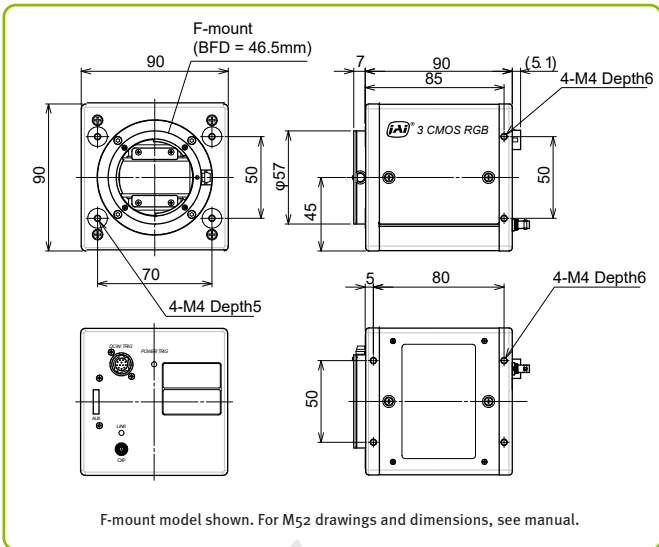

Connector pin-out

DC In / Trigger (12-pin)		AUX (10-pin)	
Pin	Signal	Camera side: 3260-10S3 (55)	Cable side: 3240-10P-C (50)
1	Ground	1	TTL Out2
2	DC in +10.8V to +26.4V	2	TTL Out3
3	Ground	3	TTL_In2
4	TTL In 4	4	NC
5	Opto in 1-	5	GND
6	Opto in 1+	6	TTL_IN3
7	TTL out 4	7	NC
8	NC	8	NC
9	TTL out 1	9	GND
10	TTL in 1	10	GND
11	DC in +10.8V to +26.4V		
12	Ground		

Spectral response

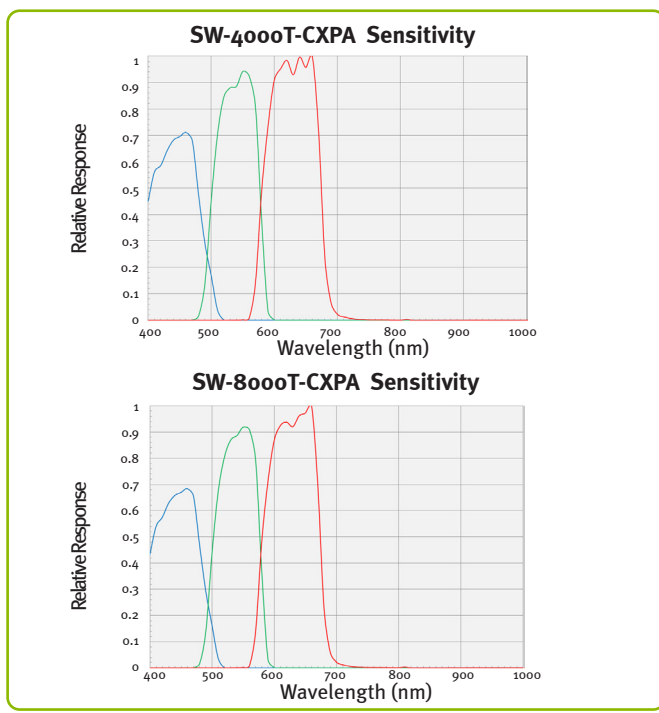

Europe, Middle East & Africa
Phone +45 4457 8888
Fax +45 4491 8880

Asia Pacific
Phone +81 45 440 0154
Fax +81 45 440 0166

Americas
Phone (Toll-Free) 1 800 445 5444
Phone +1 408 383 0300



Visit our website on www.iai.com

See the possibilities

Company and product names mentioned in this datasheet are trademarks or registered trademarks of their respective owners. IAI A-5 cannot be held responsible for any technical or typographical errors and reserves the right to make changes to products and documentation without prior notice. Jan/31/2025