

❖ **SW-4005BL-5GE**
❖ **SW-4005M-5GE**
Compact CMOS line scan camera

■ 2 x 4096 pixels
■ 1 x 4096 pixels

■ 42 kHz
■ 84 kHz

Sweep Series  

GigE[®]
VISION

Preliminary Version



- **Compact and light weight line scan camera**
- **High performance 5GBASE-T interface (5 gigabits per second)**
- **SW-4005BL-5GE: 2 x 4096 pixel output (RB-G) up to 42 kHz**
- **SW-4005M-5GE: 1 x 4096 pixel output up to 84 kHz**
- **14.336 mm wide sensor with 3.5 μm x 3.5 μm pixels**
- **Supports direct encoder connection to camera, with the ImageOutputDelay function**
- **Large variety of trigger options**
- **PRNU, DSNU, Master and Individual Gain mode*, White Balance*, Shading**
- **LUT, Color Space Conversion*, Spatial Compensations*, Horizontal Binning**
- **GigE Vision functions: Action Control, Event Control, Chunk Data**
- **8/10/12-bit output**
- **Excellent shock and vibration resistance**
- **Accepts power over GigE Vision interface or via separate 12-pin connector**
- **C-mount lens mount**

**Supported only on SW-4005BL-5GE.*



Specifications for SW-4005BL-5GE / SW-4005M-5GE

Sweep Series

Specifications	SW-4005BL-5GE / SW-4005M-5GE
Scanning system	SW-4005BL-5GE: Bilinear CMOS line scan SW-4005M-5GE: Monochrome CMOS line scan
Active pixels	SW-4005BL-5GE: 4096 x 2 pixels (RB-G) SW-4005M-5GE: 4096 x 1 pixels
Line rate (when Width = 4096)	SW-4005BL-5GE: Up to 42 kHz, variable SW-4005M-5GE: Up to 84 kHz, variable
Sensor width	14.336 mm
Pixel size	3.5 μm x 3.5 μm
Video output SW-4005BL-5GE	RGB8, RGB10V1Packed, RGB10P32, RGB12V1Packed, BiColorRGBG8, BiColorRGBG10, BiColorRGBG10P, BiColorRGBG12, BiColorRGBG12p
Video output SW-4005M-5GE	Mono8, Mono10, Mono10Packed, Mono12, Mono12Packed
Trigger Inputs	2 TTL In, 1 Opto In, Software, 4 Pulse Generators, 4 Logic Blocks, 1 Encoder Trigger, 4 Actions
Outputs	2 TTL Out
Gain SW-2005BL-5GE	Master Mode: DigitalAll odB + 30dB, Digital RB -7.9dB + 12dB Individual Mode: DigitalGBR odB + 36dB
Gain SW-2005M-5GE	DigitalAll odB + 36dB
Gamma	0.45 to 1.0 (9 steps) or 256-point LUT
Image processing	PRNU/DSNU, black level, white balance*, shading, chromatic aberration*, spatial compensation*
Color space conversion*	RGB to XYZ (CIE) or Color Correction Matrix
Exposure modes	Off, Timed, and TriggerWidth
Exposure time** (ExposureMode = Timed)	SW-4005BL-5GE: 3.22 μs ~ 15.148 ms SW-4005M-5GE: 2.17 μs ~ 15.148 ms step: 0.01 μs; Exposure time can be longer at slower line rates.
Trigger width control	SW-4005BL-5GE: 3.22 μs ~ 1 sec SW-4005M-5GE: 2.17 μs ~ 1 sec
Lens mount	C-mount (back flange distance 17.526 mm)
Operating temp. (ambient)	0°C to +45°C (20 to 80% non-condensing)
Storage temp. (ambient)	-25°C to +60°C (20 to 80% non condensing)
Vibration	10G (20 Hz to 200 Hz, XYZ directions)
Shock	80G
Regulations	CE (EN55032, EN55035) FCC Part15 Subpart B, RoHS/WEEE, KC
Power (12-pin)	Input: 10.8V to 26.4V Consumption: 6.9W typical @ +12V, 8.0W Max
Power (PoE)***	Input: 37V to 57V Consumption: 7.8W typical @ 25°C, 9.0W Max
Dimensions (H x W x L)	44 mm x 44 mm x 64 mm (without lens mount protrusions and connectors)
Weight	SW-4005BL-5GE: 186 g; SW-4005M-5GE: 185 g

*Supported only on SW-4005BL-5GE.

**Including Exposure offset time

***When using the PoE function, use a UTP Ethernet cable

Ordering Information

SW-4005BL-5GE	CMOS bilinear RB-G camera
SW-4005M-5GE	CMOS monochrome line scan camera

Dimensions

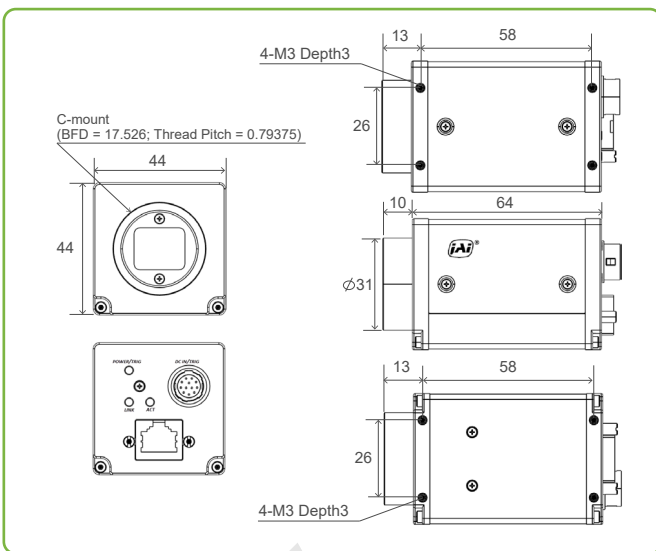

Connector pin-out

DC In / Trigger (12-pin)

HR10A-10R-12PB(71)

Pin	Description
1	Ground
2	DC in +10.8V to +26.4V
3	Ground
4	TTL in 4
5	Opto in 1-
6	Opto in 1+
7	TTL out 4
8	NC
9	TTL out 1
10	TTL in 1
11	DC in +10.8V to +26.4V
12	Ground

Spectral response

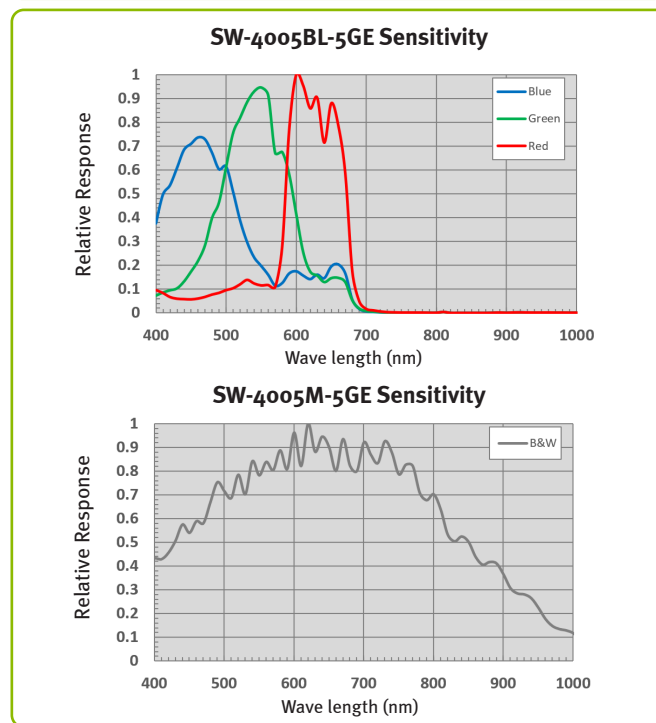

Europe, Middle East & Africa
Phone +45 4457 8888
Fax +45 4491 8880

Asia Pacific
Phone +81 45 440 0154
Fax +81 45 440 0166

Americas
Phone (Toll-Free) 1 800 445 5444
Phone +1 408 383 0300



Visit our website on www.jai.com

See the possibilities

Company and product names mentioned in this datasheet are trademarks or registered trademarks of their respective owners. IAI-A-S cannot be held responsible for any technical or typographical errors and reserves the right to make changes to products and documentation without prior notice.

Mar 05, 2025